

200200 ProTIM-R

Datasheet

Bently Nevada Machinery Condition Monitoring

163662 Rev. AJ

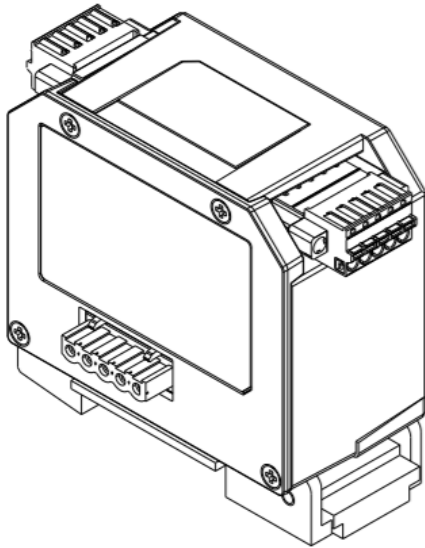

Description

The 200200 dual-input ProTIM-R (DIN rail mount) provides 2 channels of measurement. All acceleration-to-velocity (A-V) channels condition the signal from an accelerometer and integrate it to velocity units. The low frequency A-V channels are better suited for slower speed applications. A-V with Acceleration Enveloping (AE) channels provide both integrated velocity units and advanced AE signal conditioning. Temperature channel types include K-type thermocouples and 100W Platinum (Pt) RTDs with electrical isolation. Each channel is independent and specified when the ProTIM is ordered.

Table 1: ProTIM Measurement Types and Transducers

Measurement Type	Interfaced Transducer
Acceleration-to-Velocity (General Purpose)	200150
Low Frequency Acceleration-to-Velocity	200155
Acceleration-to-Velocity with AE	200157
K-type Thermocouple	2001251
2, 3, or 4 Wire Platinum RTD	Industry standard
Rack Buffered Output (RBO)	Monitor
Process Variable (PV)	Monitor
Pressure	120M1644
Displacement	330101/330103



1 The 200125 is the recommended Trendmaster sensor for temperature measurements when the range of a K-type thermocouple is adequate. We do not recommend the use of other K-type thermocouples due to the unique electrical isolation requirements of the Trendmaster system, and highly recommend the use of only non-grounded RTDs and non-grounded tip thermocouples to prevent ground loops. Failure to comply may result in Not OK or NO DATA conditions, inaccurate readings, or ProTIM-R damage. Consult the factory for further information.

Specifications



 All specifications are at $+25 \pm 5^\circ\text{C}$ ($+77 \pm 9^\circ\text{F}$) unless otherwise specified. Operation outside the specified limits will result in false or inaccurate readings.

Table 1: ProTIM and Transducers Frequency Responses

Device	Lower Freq	Upper Freq
200200-01	1 Hz	1 KHz
200200-05	1 Hz	1 KHz
200200-06 AV	1 Hz	1 KHz ¹
200200-06 AE	1 Hz	500 Hz ¹
200150 XDCR	10 Hz	1 KHz
200155 XDCR	3 Hz	10 KHz ²
200157 XDCR	10 Hz	10 KHz

 ¹ 2002XX-06 ProTIM AE circuitry allows enveloping input frequency up to 10 KHz.
² 200155 has a long settling time. Therefore, it should only be used for low frequency acceleration to velocity channel types.

200200 ProTIM-R and 200150, 200155, 200157 or 200125 transducer systems

For detailed specification on the transducers, refer to the individual transducer data sheets.

Electrical: A-V (General Purpose) Channels (with 200150)

Measurement Range	0 to 50 mm/s pk (0 to 2 in/s pk)
Over Range	63 mm/s pk (2.5 in/s pk)
Resolution	0.025 mm/s (0.001 in/s pk)

	nominal
Accuracy	$\pm 15\%$ at 80 Hz
Frequency Response ¹	10 Hz to 1 kHz (600 cpm to 60,000 cpm) $\pm 20\%$ (± 2 dB) ¹ This Frequency response represents the System ProTIM & Transducer. For details on individual device frequency response, Specifications
Not OK Range	Open transducer signal, power, or common is "Not OK". Shorted leads are "Not OK" except for SIG+ shorted to SIG- or common shorted to shield.

Electrical: Low Frequency A-V Channels (with 200155)

Measurement Range	0 to 50 mm/s pk (0 to 2 in/s pk)
Over Range	63 mm/s pk (2.5 in/s pk)
Resolution	0.025 mm/s (0.001 in/s pk) nominal
Accuracy	$\pm 15\%$ at 80 Hz
Frequency Response ¹	3 Hz to 1 kHz (180 cpm to 60,000 cpm) $\pm 10\%$ (± 0.9 dB) ² This Frequency response represents the System ProTIM & Transducer. For details on individual device frequency response, Specifications  ² The A-V circuitry attenuates frequencies above 1 kHz. Use of the 200155 transducer to obtain higher frequency information will be ineffective.
Not OK Range	Open transducer signal, power, or common is "Not OK". Shorted leads are "Not OK" except for SIG+ shorted to SIG- or common shorted to shield.

Electrical: A-V w/ AE Channels (with 200157)



Measurement Range	0 to 50 mm/s pk (0 to 2 in/s pk)
Over Range	63 mm/s pk (2.5 in/s pk)
Resolution	0.025 mm/s (0.001 in/s pk) nominal
Accuracy	±15% at 80 Hz
Frequency Response ¹ A-V	10 Hz to 1 kHz (600 cpm to 60,000 cpm) ± 20% (± 2.0 dB) ²
AE	<p> 10 Hz to 500 Hz (600 cpm to 30,000 cpm) ± 20% (±2.0 dB) ³ This Frequency response represents the System ProTIM & Transducer. For details on individual device frequency response, Specifications</p> <p>² The A-V circuitry attenuates frequencies above 1 kHz. Use of the 200157 transducer to obtain higher frequency information will be ineffective. AE signals up to 10 kHz are processed at the ProTIM.</p> <p> ³ The 500 Hz filter has a 4-pole attenuation slope. The enveloped signal will range between 1Hz to 500 Hz.</p>
Not OK Range:	Open transducer signal, power, or common is "Not OK". Shorted leads are "Not OK" except for SIG+ shorted to SIG- or common shorted to shield.

Table 2: ProTIM and Transducers Compatibility

Device	200150	200155	200157
200200-01	Great	N/A	OK ¹
200200-05	OK ²	Great	OK ²
200200-06	OK ³	N/A	Great



¹ ProTIM does not offer AE capability and will only accept frequencies up to 1 KHz whereas 200157 will go up to 10 KHz.



² Lower transducer limit is 10 Hz, whereas 200155 will operate down to 3 Hz.



³ ProTIM's AE circuit accepts frequencies up to 10 KHz, but 200150 operates only up to 1 KHz.

Electrical: Temperature Channels

Measurement Range	-18 °C to +204 °C (0 °F to +400 °F)
Resolution	0.07 °C (0.12 °F)
Accuracy	
K-Type TC	±8 °C (±14 °F), including ProTIM-R, thermocouple & lead wire error, maximum length of 6 meters. Maximum temperature ramp rate: ±0.5 °C/min.
RTD	±4.45 °C (±8 °F), RTD lead wire error not included
OK Range	-31 °C to +213 °C (-25 °F to +415 °F)
Not OK Condition	Temperatures outside the OK Range Open RTD or thermocouple wires are "Not OK"

RTD Compensation Coefficient Alpha in W/W/°C

European	0.00385
US Industrial	0.00392
Software Compensation	At host computer

Electrical: Rack Buffered Output Channels

Measurement Range	AC: 1Vpp to 8Vpp full scale DC: 0 to -20Vdc
-------------------	--

Input Signal	Full Scale	OverRange
LOAC_IN	1.6Vpp	1.92Vpp
HIAC_IN	8Vpp	9.6Vpp
DCGAP_IN	DC: -20VDC AC: 1Vpp	DC: -24.4VDC AC: See Note

Resolution	AC: ±1% of full-scale value at
------------	--------------------------------

	100Hz DC: ±500 mV, absolute accuracy
Frequency Response	10Hz to 3 KHz (+0 to -5%)
Not OK Range	Input signal is out of range, Input signal mis-wired.



AC over range of DCGAP_IN occurred when $[V_{pp}(AC)/2 + (1-V_{dc} \cdot 0.15) - 2.5V] > 2.181V$

Electrical: Process Variable Channels

Measurement Range	Current: +4mA to +20mA Voltage: +1Vdc to 5Vdc
Over Range	Current: <+3mA or >+22mA Voltage: <+0.8Vdc or >+5.5Vdc
Resolution	±1% of full-scale value Typical
OK Range	Current: Over +3.2mA Voltage: Over 0.8Vdc
Frequency Response	DC to 3 KHz

Electrical: Pressure Channels

Measurement Range	0 to 50mV
Resolution	±8.5% of the transducer full-scale rating (transducer accuracy not included)
OK Range	1Vdc to 3Vdc Bias from transducer
Frequency Response	Less than 3 KHz

Keyphasor Rotational Speed Channels (with 330101/330103)

Measurement Range	0.1 to 600 Hz (6 to 36000 RPM)
Transducer Range	10 to 50 mils (0.254 to 1.27 mm)
Resolution	1 RPM
Accuracy	Within 0.015% of true RPM.
Frequency Response	Minimum Trigger Width 9.0 mm (0.35 in) Minimum Trigger Relief 1.25 mm (0.05 in)
Not OK Range	Open/short transducer signal, Power or common is "Not OK".

Displacement Channels (with 330101/330103)



Input	Used with our 3300 XL 8 mm probe or 3300 5 mm probe and extension cable (5 metre system) only.
Output Voltage Range	-3.0 to 3.0 V (Over Specified linear range)
Transducer Linear Range	10 to 50 mils (0.254 to 1.27 mm)
Scale Factor	120 mV/mil +/-10%
Accuracy Over gap Range	+/-1.2 mils @ mid-scale range.
Frequency Response	DC to 3 KHz (0 to 180,000 cpm).
Minimum Target Size	15.2 mm (0.6in) diameter (flat target)
Shaft Diameter:	Minimum: 50.8 mm (2 in)

Recommended minimum: 76.2 mm (3 in)

Measurements on shaft diameters smaller than 50 mm (2 in) usually require close spacing of radial vibration or axial position transducers with the potential for their electromagnetic emitted fields to interact with one another (cross-talk), resulting in erroneous readings. Care should be taken to maintain minimum separation of transducer tips, generally at least 40 mm (1.6 in) for axial position measurements or 74 mm (2.9 in) for radial vibration measurements. Radial vibration or position measurements on shaft diameters smaller than 76.2 mm (3 in) will generally result in a change in scale factor. Consult Performance Specification 159484 for additional information.

Not OK Range	Open/short transducer signal, Power or common is "Not OK".
--------------	--

Environmental Limits

Operating Temperature	Standard: -40 °C to +85 °C (-40 °F to +185 °F)  RTD, K-Type TC and Thermocouple pro-TIM have a limited operating temperature of -25° C to +85° C.
Storage Temperature	-40°C to +100°C (-40 °F to +212 °F)
Humidity	100% non-condensing  Apply DC4 grease on connector contacts to improve environmental performance and prevent corrosion.

Enclosure Type	Type 4
----------------	--------

Mechanical

Housing Material	Powder-coated Aluminum
Weight	545 g (19 oz)
Dimensions	Polyester Housing Dimensions or Stainless Steel Housing Dimensions on pages 13 & 14.

200151 and 200152 Transducer Cables

Use to connect the acceleration transducers to the ProTIM-R.

Operating Temperature	-20 °C to +100 °C (-4 °F to +212 °F). Note: These cables may be used at lower temperatures down to -40 °C (-40 °F), if the cable is not allowed to move or flex. Flexing these cables at temperatures below -20 °C (-4 °F) may damage them.
Minimum Bend Radius	63.5 mm (2.5 in)
Construction	4-conductor (22 AWG) with foil shield and drain wire (100% coverage), polyvinyl chloride (PVC) outer jacket.

Connectors

200151 Cables	Screw-on, 5-pin, keyed connector on the ProTIM-R end and a PT06F8-4S (or equivalent) on the transducer end. Connector coupling nuts consist of 1/2-20 UNF-threaded 2011 T3 aluminum or UV-stabilized black nylon. Contact material is gold-plated
---------------	---

	nickel-coated brass.
200152 Cables	PT06F8-4S (or equivalent) on the transducer end; stripped stranded wire at ProTIM end. Connector coupling nut material is 1/2-20 2011 T3 aluminum or UNF-threaded nickel-plated brass. Connector contact material is gold-plated brass.
Classifications:	Cable assembly meets UL 2238. Cable meets IP67 ingress protection.

85033 Trendmaster SPA/TIM line cable

Use to connect a Signal Processing Adapter (SPA) to the ProTIM. For substitutions, reference guide 101206.

Operating Temperature	-70 °C to +200 °C (-94 °F to +392 °F).
Conductors	4x 18 AWG stranded tinned copper 1x 18 AWG stranded copper, tinned overcoat uninsulated drain wire
Shielding	100% aluminum Mylar foil out with helically applied drain wire 85% braided tinned copper

Insulation

Conductors	Fluoroethylene propylene (FEP) Teflon material 0.25 mm (0.010 in) thick
Outer	FEP Teflon material 0.38 mm (0.015 in) thick

Classifications	NEC article 725 class 3 UL Listed
Voltage rating	300 Vrms

Capacitance

Between Conductors	131 pF/m (40 pF/ft.)
Between Conductor and Drain Wire	262 pF/m (80 pF/ft)

Compliance and Certifications

FCC

This device complies with part 15 of the FCC Rules. Operation is subject to the following two conditions:

- This device may not cause harmful interference.
- This device must accept any interference received, including interference that may cause undesired operation.

EMC

EN 61000-6-2 :2005

EN 61000-6-4:2007 +A1:2011

EMC Directive 2014/30/EU

RoHS

RoHS Directive 2011/65/EU

ATEX

EN 60079-0: 2012/A11:2013

EN 60079-11:2012

EN 60079-15:2010

EN 60079-28:2015 (DSM 149744 only)

EN 60079-31:2014 (TMGI 162459-01 only)

ATEX Directive 2014/34/EU

Maritime

ABS 2009 Steel Vessels Rules

1-1-4/7.7,4-8-3/1.11.1,4-9-7/13

Hazardous Area Approvals

 For the detailed listing of country and product specific approvals, refer to the *Approvals Quick Reference Guide* (108M1756) available from Bently.com.

CSA/NRTL/C (Approval Options 05)

Installed with intrinsically safe zener barriers per drawing 112M7732	<p>Ex ia IIC T4 Ga</p> <p>Class I Zone 0: AEx ia IIC T4 Ga Class I, Div 1 Groups A, B, C & D Class II, Groups E, F & G</p> <p>Class III</p> <p>T4 @ -40° C ≤ Ta ≤ +100° C (-40° F ≤ Ta ≤ +212° F)</p>
Installed without barriers per drawing 112M7732	<p>Ex nA IIC T4 Gc</p> <p>Class I Zone 2: AEx nA IIC T4 Gc Class I, Div 2 Groups A, B, C & D</p> <p>T4 @ -40° C ≤ Ta ≤ +100° C (-40° F ≤ Ta ≤ +212° F)</p>

ATEX/IECEx

ProTIMs (200200 and 200250)

	<p> II 1 G Ex ia IIC T4 GC</p> <p>II 3 G Ex nA IIC T4 Gc</p> <p>T4 @ Ta = -40°C to +100°C</p>
--	--

Trendmaster DSM (149744)

	<p> II 3 G Ex nA IIC T4 GC</p> <p>II 3(3) G Ex nA [ic] IIC T4 Gc II 3(3) G Ex nA op is [op is T4 Gc] IIC T4 Gc</p> <p>T4 @ Ta = -20°C to +65°C</p>
--	--

TMGI (162459-01)

	<p> II (1) G [Ex ia Ga] IIC</p> <p>II(1) D [Ex ia Da] IIIC</p> <p>II 3 (1) G Ex nA [is Ga] IIC T4 Gc</p> <p>II 3(1) D Ex tc [ia Da] IIIC T140°C Dc IP5X</p> <p>T4 @ Ta = -20°C to +65°C</p>
--	---

Ordering Information



For the detailed listing of country and product specific approvals, refer to the *Approvals Quick Reference Guide* (108M1756) available from Bently.com.

ProTIM-R

200200-AA-BB-CC

A: Channel AA Input Option

01	Acceleration to Velocity (200150)
02	K-Type Thermocouple (200125)
03	2 or 3 Wire Pt. RTD
04	4 Wire Pt. RTD
05	Low Freq Accel-to-Velocity (200155)
06	Accel to Velocity w/AE (200157)
07	Rack buffered Output
08	Process Variable
09	Pressure (120M1644)
10	Keyphasor (330101/330103)
11	Displacement (330101/330103)

B: Channel BB Input Option

01	Acceleration to Velocity (200150)
02	K-Type Thermocouple (200125)
03	2 or 3 Wire Pt. RTD
04	4 Wire Pt. RTD
05	Low Freq Accel-to-Velocity (200155)
06	Accel to Velocity w/AE (200157)
07	Rack buffered Output
08	Process Variable

09	Pressure (120M1644)
11	Displacement (330101/330103)



BB option availability is dependent on AA options chosen. Not all BB options are available with each AA option.

C: Approvals

01	None
05	Multiple Approvals

Transducer Cable (for use with 200150, 200150, and 200157 Accelerometers)

200151-AA-BB-CC



Use the 200151 with the 200200 ProTIM only with applications using either a 142485 Housing Cable Adapter or a 141887 Conduit Cable Adapter.

A: Cable Length:

20	2.0 metre (6.6 feet) cable
40	4.0 metre (13.1 feet) cable
60	6.0 metre (19.7 feet) cable

B: Outer Jacket Option:

02	Blue, unarmored
03	Blue, armored

C: Additional Features:

00	Standard coupling nut
02	Nylon coupling nut
10	Knurled coupling nut

Transducer Cable (for use with 200150, 200155 and 200157 accelerometers)

200152-AA-BB

A: Cable Length:

0 4	4.0 metre (13.1 feet) cable
1 5	15.0 metre (49.2 feet) cable
2 5	25.0 metre (82.0 feet) cable (for use with 200150 only)

B: Additional Features:

0 0	Standard coupling nut
1 0	Knurled coupling nut

Transducer Cable

120M1648 -AA (for use with 120M1644 pressure transducer.

A: Cable Length:

0 5	0.5 metre (1.6 feet) cable
1 0	1.0 metre (3.3 feet) cable
1 5	1.5 metre (4.9 feet) cable
2 0	2.0 metre (6.6 feet) cable
4 0	4.0 metre (13.1 feet) cable
6 0	6.0 metre (19.7 feet) cable
9 0	9.0 metre (29.5 feet) cable

Pressure Transducer

120M1644-AAAA

A: Pressure rating

0030	0 to 30 PSI SG
0050	0 to 50 PSI SG
0100	0 to 100 PSI SG
0300	0 to 300 PSI SG
0500	0 to 500 PSI SG
1000	0 to 1000 PSI SG
1500	0 to 1500 PSI SG
2000	0 to 2000 PSI SG

Accessories

138493-01	Replacement DIN-mount mounting pad.
136806-01	T-TIM Assembly.
141887-01	Single Conduit Cable Adapter.
141887-02	Double Conduit Cable Adapter.

	See Dual Conduit Cable Adapter .	00500128	Terminal Connector. For Transducer inputs into ProTIM-R.
142485-01	Anodized aluminum housing Cable Adapter. See Housing Cable Adapter .	02180005	Jumper. For the RTD ProTIM-R terminals.
149831-01	Trendmaster DSM Datasheet.	03814237	Conduit Hub. 1/2-14 NPT.
163986-01	ProTIM-R Installation Manual.	03817040	Bonding and Ground Wedge. 1/2 NPT.
164045	Extra Female Terminal Plugs. For TIM line connections.	03839129	Conduit Fitting. 1/2-14 NPT.
164046	Extra Male Terminal Plugs. For TIM line connections.	03839240	Cable Seal. 1/4-12 NPT. Diameter 5.0 to 6.7 mm (0.20 to 0.26 in); Use with 200152 cable.
164352	T-Connector. For splitting TIM line cable into 2 directions.	03839241	Cable Seal. 1/4-12 NPT. Diameter 1.9 to 3.4mm (0.07 to 0.13 in).
85033-01-00	150 Meter (500 ft) Cable. For TIM line, no connectors.	03839242	Cable Seal. 1/4-12 NPT. Diameter 3.4 to 5.0 mm (0.13 to 0.20 in). Use with 200125 armored thermocouple.
85033-02-00	300 Meter (1000 ft) Cable. For TIM line, no connectors.	03839243	Cable Seal. 1/2-14 NPT. Diameter 6.4 to 7.9 mm (0.25 to 0.31 in).
88312-01	4-unit IS Polyester W/P Housing. Div 1, Type 4X. Houses 4 ProTIM-R units maximum. See Polyester Housing Dimensions .	03840490	Thread Seal. For 1/4 -12 NPT fittings.
88313-01	2-unit IS Polyester W/P Housing. Div 1, Type 4X. Houses 2 ProTIM-R units maximum. See Polyester Housing Dimensions .	03880243	Square Cut O-ring. For 1/2-14 NPT fittings.
88314-01	4-unit IS SST W/P Housing. Div1, Type 4X, Houses 4 TIMs maximum. See Stainless Steel Housing Dimensions .	04500006	Dow Corning 4, Electrical Insulating Compound (5.3 Oz).
88315-01	2-unit IS SST W/P Housing. Div 1, Type 4X. Houses 2 TIMs maximum. See Stainless Steel Housing Dimensions .		
85716-01	2-unit Polyester W/P Housing. Div 2, Type 4X. Houses 2 ProTIM-R units maximum. See Polyester Housing Dimensions		
85717-01	4-unit Polyester W/P Housing. Div 2, Type 4X,. Houses 4 ProTIM-R units maximum. See Polyester Housing Dimensions .		

Graphs and Figures

Table 1: Channel Types Cross-compatibility

			Channel A											
			Acceleration to Velocity	K-Type Thermocouple	2 or 3 Wire Pt. RTD	4 Wire Pt. RTD	Low Freq Accel-to-Velocity	Accel to Velocity w/AE	Rack buffered Output	Process Variable	Pressure	Keyphasor	Displacement	
			01	02	03	04	05	06	07	08	09	10	11	
<p>The 200200 dual-input ProTIM-R (DIN rail mount) provides 2 channels of measurement.</p> <p>The 200250 dual-input ProTIM-C (Conduit mount) provides 2 channels of measurement.</p>														
Channel B	Acceleration to Velocity	01	OK											
	K-Type Thermocouple	02	OK	OK			OK	OK						
	2 or 3 Wire Pt. RTD	03	OK		OK		OK	OK						
	4 Wire Pt. RTD	04	OK			OK	OK	OK						
	Low Freq Accel-to-Velocity	05	OK				OK	OK						
	Accel to Velocity w/AE	06						OK						
	Rack buffered Output	07							OK					
	Process Variable	08								OK				
	Pressure	09									OK			
	Keyphasor	10										OK	OK	
	Displacement	11										OK	OK	

Note: All dimensions in millimetres (inches) except as noted.

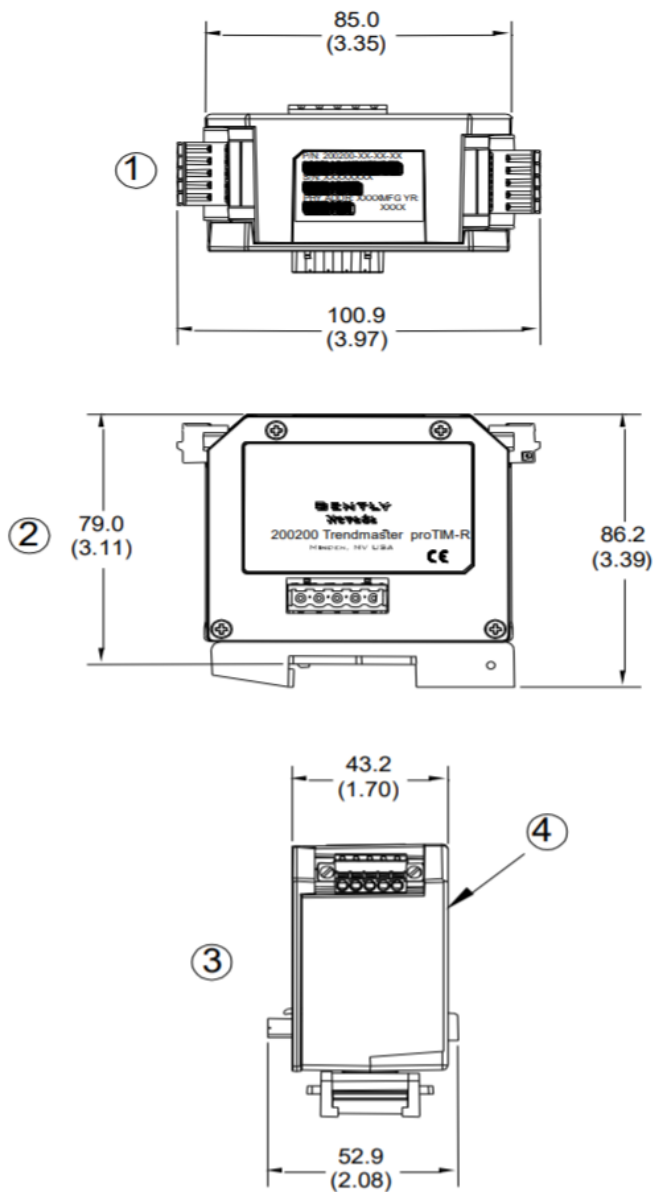

1. Top view
2. Side view
3. Side view #2
4. Powder coated aluminum housing

Figure 1: ProTIM Dimensional Diagram

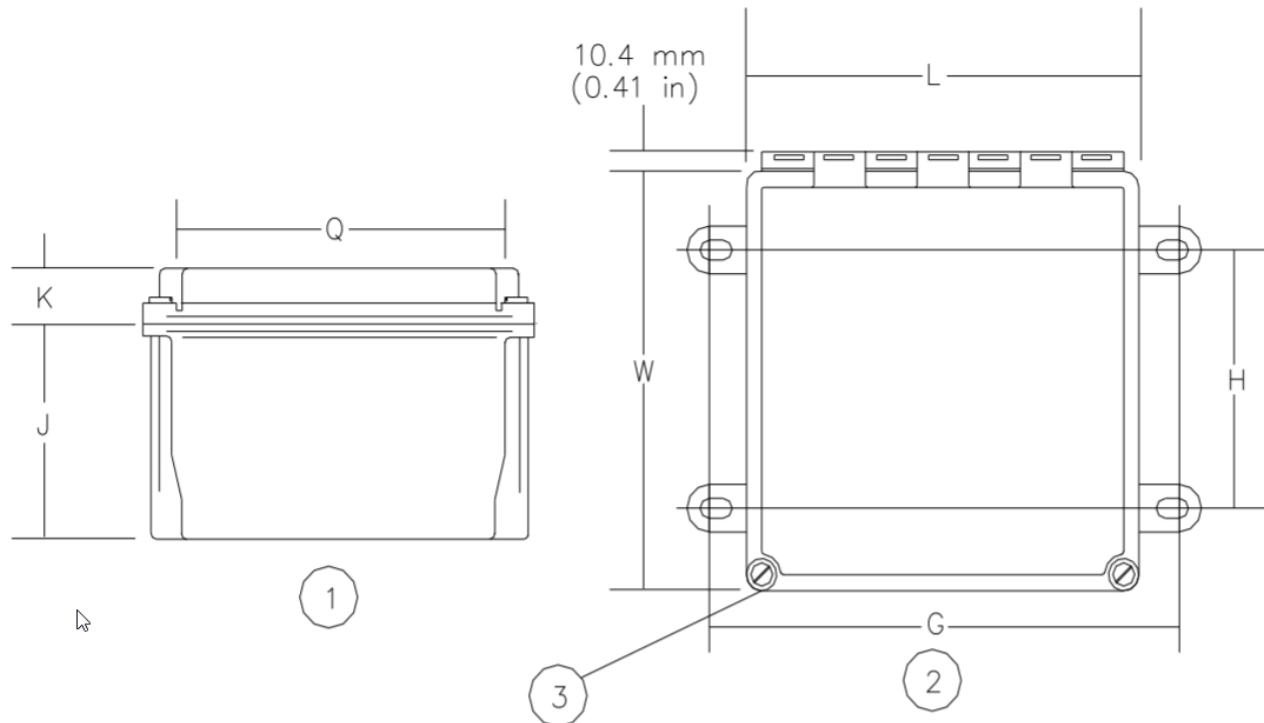

1. Side view. [ProTIM Enclosure Dimensions](#) for dimensions.
2. Top view. [ProTIM Enclosure Dimensions](#) for dimensions.
3. If not using Quick Release, use 10-32 pan head screw (2 places).

Figure 2: Polyester Housing Dimensions

Table 2: ProTIM Enclosure Dimensions

Part number	Overall (L x W)	Mounting (G x H)	J	K	Q
85716-01 (2-position)	165 x 165 (6.50 x 6.50)	171 x 102 (6.75 x 4.00)	82.5 (3.25)	25.4 (1.00)	143 (5.64)
88313-01 (2 position)	165 x 165 (6.50 x 6.50)	171 x 102 (6.75 x 4.00)	82.5 (3.25)	25.4 (1.00)	143 (5.64)
85717-01 (4 position)	267 x 216 (10.50 x 8.50)	273 x 152 (10.75 x 6.00)	125 (4.94)	33.3 (1.31)	244 (9.61)
88312-01 (4 position)	267 x 216 (10.50 x 8.50)	273 x 152 (10.75 x 6.00)	125 (4.94)	33.3 (1.31)	244 (9.61)

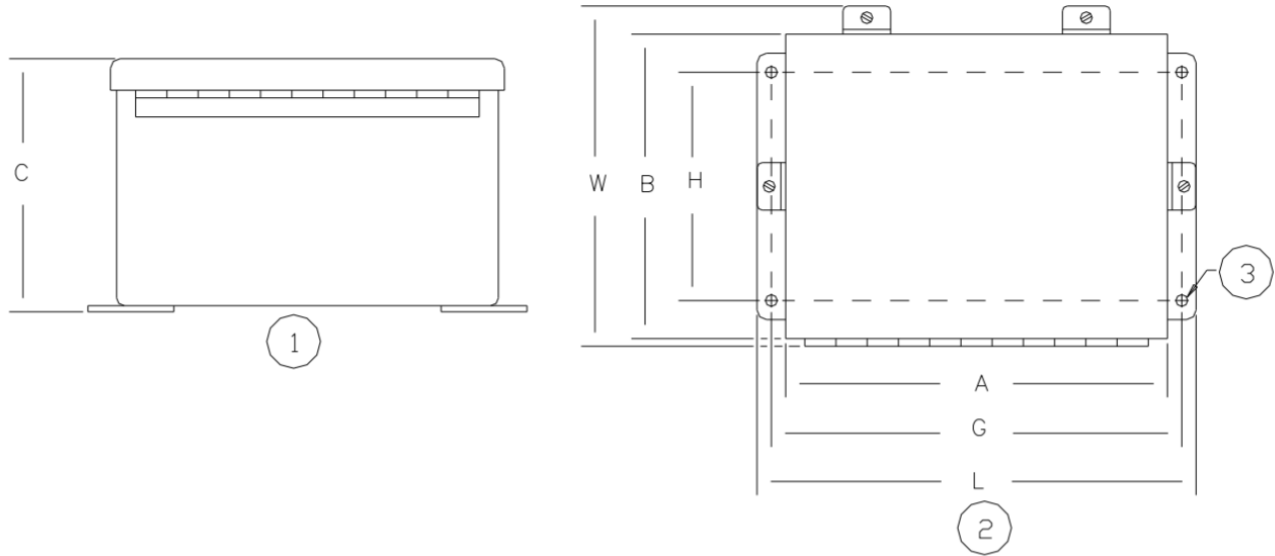

1. Side view. [Stainless Steel ProTIM Enclosure Dimensions](#) for dimensions.
2. Top view. [Stainless Steel ProTIM Enclosure Dimensions](#) for dimensions.
3. 8 mm (0.31 in) diameter, 4 places



The number of clamps and the placement is shown for the large enclosure. The small enclosure has only one clamp, centered on the side opposite the hinge.

Figure 3: Stainless Steel Housing Dimensions

Table 3: Stainless Steel ProTIM Enclosure Dimensions

Part number	Overall (L x W)	Mounting (G x H)	Box Size (A x B x C)
88315-01 (2-position)	191 x 176 (7.50 x 6.94)	171 x 102 (6.75 x 4.00)	152 x 152 x 102 (6.00 x 6.00 x 4.00)
88314-01 (4 position)	292 x 227 (11.50 x 8.94)	273 x 152 (10.75 x 6.00)	254 x 203 x 152 (10.00 x 8.00 x 6.00)

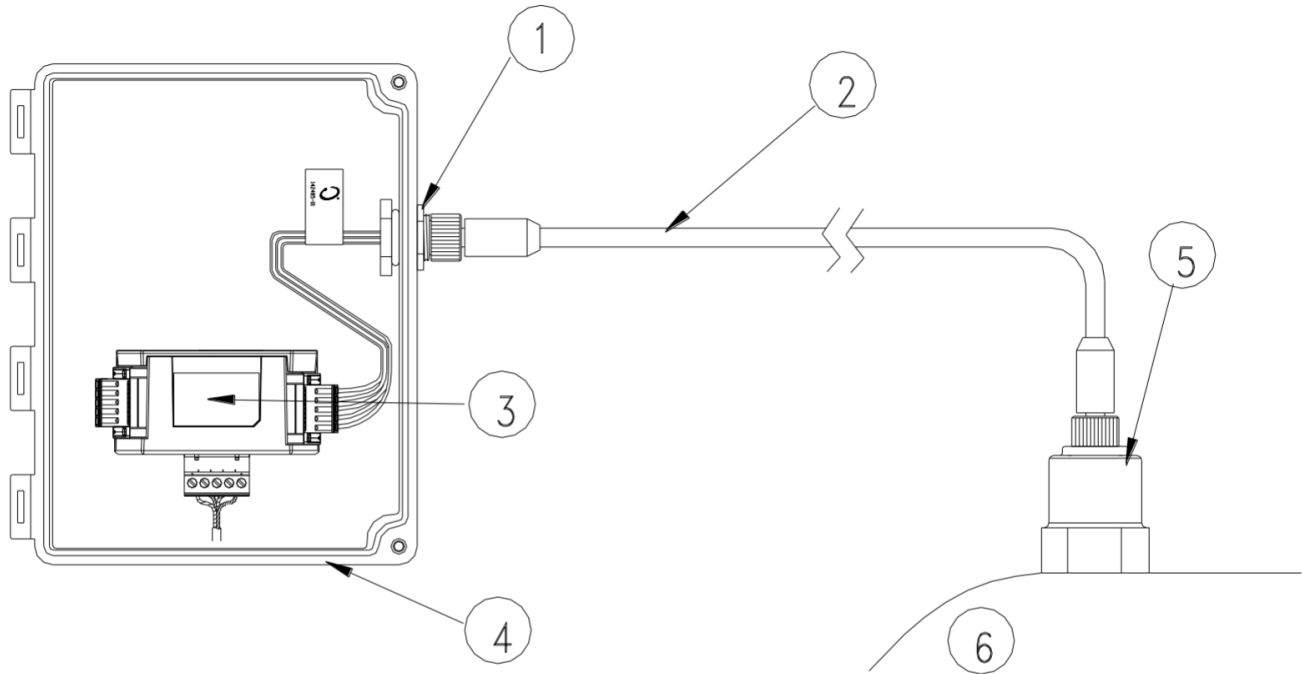

1. Housing cable adapter, 142485-01
2. 200151 cable
3. Accel to Velocity ProTIM-R
4. TIM housing
5. 200150 accelerometer
6. Machine casing

Figure 4: Housing Cable Adapter

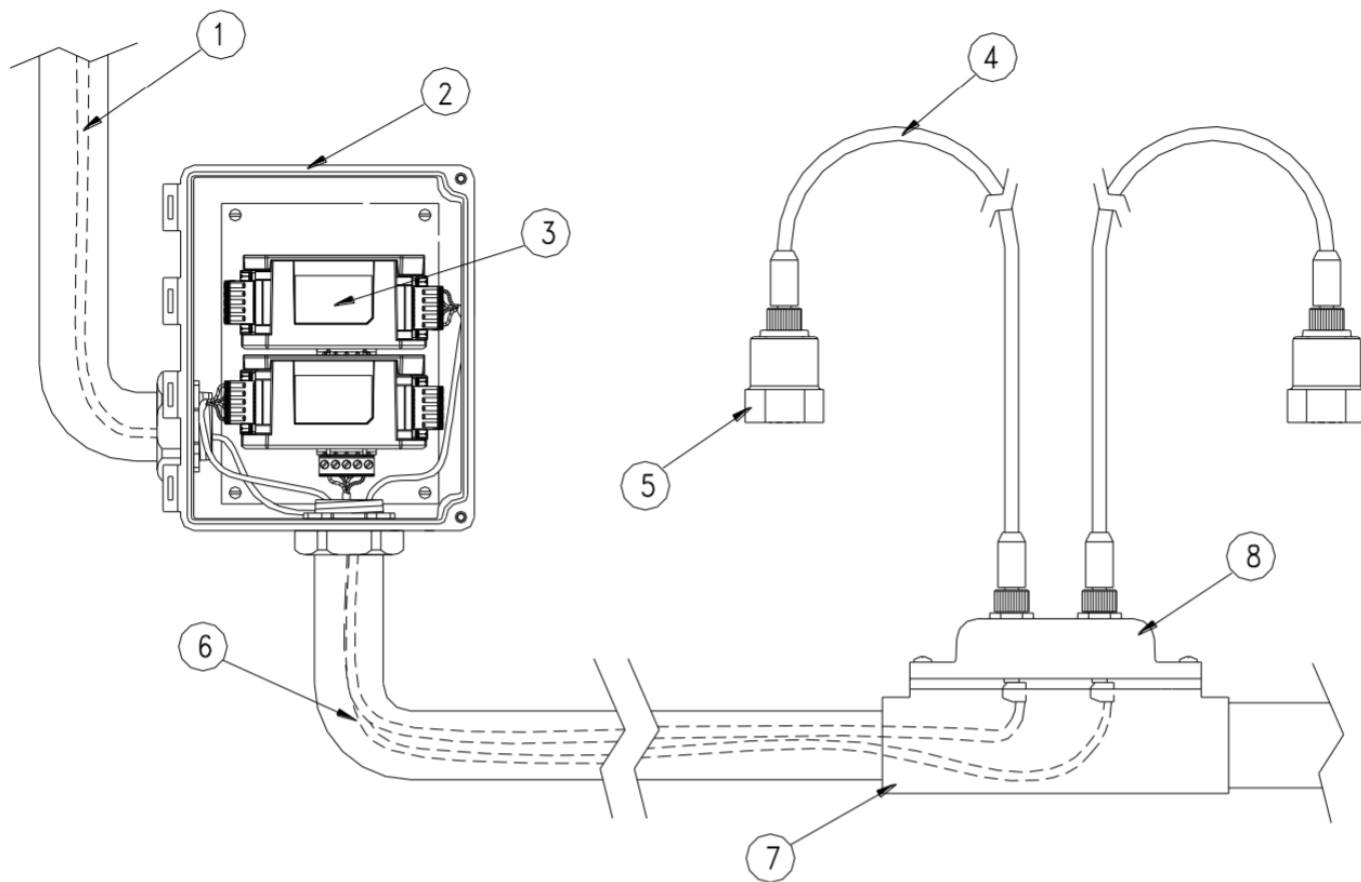

1. To SPA
2. TIM housing
3. Accel to Velocity ProTIM-R
4. 200151 cable
5. 200150 accelerometer
6. Wiring in rigid conduit
7. 1-inch conduit body near machine
8. 141887-02 Conduit Cable Adapter

Figure 5: Dual Conduit Cable Adapter

Copyright 2020 Baker Hughes Company. All rights reserved.



Bently Nevada, Orbit Logo and Keyphasor are registered trademarks of Bently Nevada, a Baker Hughes Business, in the United States and other countries. The Baker Hughes logo is a trademark of Baker Hughes Company. All other product and company names are trademarks of their respective holders. Use of the trademarks does not imply any affiliation with or endorsement by the respective holders.

Baker Hughes provides this information on an "as is" basis for general information purposes. Baker Hughes does not make any representation as to the accuracy or completeness of the information and makes no warranties of any kind, specific, implied or oral, to the fullest extent permissible by law, including those of merchantability and fitness for a particular purpose or use. Baker Hughes hereby disclaims any and all liability for any direct, indirect, consequential or special damages, claims for lost profits, or third party claims arising from the use of the information, whether a claim is asserted in contract, tort, or otherwise. Baker Hughes reserves the right to make changes in specifications and features shown herein, or discontinue the product described at any time without notice or obligation. Contact your Baker Hughes representative for the most current information.

The information contained in this document is the property of Baker Hughes and its affiliates; and is subject to change without prior notice. It is being supplied as a service to our customers and may not be altered or its content repackaged without the express written consent of Baker Hughes. This product or associated products may be covered by one or more patents. See [Bentley.com/legal](https://www.bentley.com/legal).

1631 Bently Parkway South, Minden, Nevada USA 89423
Phone: 1.775.782.3611 or 1.800.227.5514 (US only)
[Bentley.com](https://www.bentley.com)