

# 200250 ProTIM-C

## Datasheet

Bently Nevada Machinery Condition Monitoring

163663 Rev. AA



### Description

The 200250 dual-input ProTIM-C (conduit mount) provides 2 channels of measurement. All acceleration-to-velocity (A-V) channels condition the signal from an accelerometer and integrate it to velocity units. The low frequency A-V channels are better suited for slower speed applications. A-V with Acceleration Enveloping (AE) channels provide both integrated velocity units and advanced AE signal conditioning. Temperature channel types include K-type thermocouples and 100Ω Platinum (Pt) RTDs with electrical isolation. Each channel is independent and specified when the ProTIM is ordered.

**Table 1: ProTIM Measurement Types and Transducers**

Measurement Type	Interfaced Transducer
Acceleration-to-Velocity (General Purpose)	200150
Low Frequency Acceleration-to-Velocity	200155
Acceleration-to-Velocity with AE	200157
K-type Thermocouple	200125
2-, 3-, or 4-Wire Platinum RTD	Industry standard
Rack Buffered Output (RBO)	Monitor
Process Variable (PV)	Monitor
Pressure	120M1644
Displacement	330101/330103



## Specifications

All specifications are at  $+25 \pm 5^\circ\text{C}$  ( $+77 \pm 9^\circ\text{F}$ ) unless otherwise specified. Operation outside the specified limits will result in false or inaccurate readings.

**Table 1: ProTIM and Transducers Frequency Responses**

Device	Lower Freq	Upper Freq
200250-01	1 Hz	1 KHz
200250-05	1 Hz	1 KHz
200250-06 AV	1 Hz	1 KHz <sup>1</sup>
200250-06 AE	1 Hz	500 Hz <sup>1</sup>
200150 XDCR	10 Hz	1 KHz
200155 XDCR	3 Hz	10 KHz <sup>2</sup>
200157 XDCR	10 Hz	10 KHz

<sup>1</sup> 2002XX-06 ProTIM AE circuitry allows enveloping input frequency up to 10 KHz.

<sup>2</sup> 200155 has a long settling time. Therefore, it should only be used for low frequency acceleration to velocity channel types.

### 200250 ProTIM-C and 200150, 200155, 200157 or 200125 transducer systems

For detailed specification on the transducers, refer to the individual transducer data sheets.

## Electrical

### A-V (General Purpose) Channels (with 200150)

Measurement Range	0 to 50 mm/s pk (0 to 2 in/s pk)
Over Range	63 mm/s pk (2.5 in/s pk)
Resolution	0.025 mm/s (0.001 in/s pk) nominal
Accuracy	$\pm 15\%$ at 80 Hz

Frequency Response <sup>1</sup>	10 Hz to 1 kHz (600 cpm to 60,000 cpm) $\pm 20\%$ ( $\pm 2$ dB).
Not OK Range	Open transducer signal, power, or common is "Not OK". Shorted leads are "Not OK" except for SIG+ shorted to SIG- or common shorted to shield.

<sup>1</sup> This Frequency response represents the System ProTIM & Transducer. For details on individual device frequency response refer to [ProTIM and Transducers Frequency Responses](#)

### Low Frequency A-V Channels (with 200155)

Measurement Range	0 to 50 mm/s pk (0 to 2 in/s pk)
Over Range	63 mm/s pk (2.5 in/s pk)
Resolution	0.025 mm/s (0.001 in/s pk) nominal
Accuracy	$\pm 15\%$ at 80 Hz
Frequency Response <sup>1</sup>	3 Hz to 1 kHz (180 cpm to 60,000 cpm) $\pm 10\%$ ( $\pm 0.9$ dB) <sup>2</sup> .
Not OK Range	Open transducer signal, power, or common is "Not OK". Shorted leads are "Not OK" except for SIG+ shorted to SIG- or common shorted to shield.

<sup>1</sup> This Frequency response represents the System ProTIM & Transducer. For details on individual device frequency response refer to [ProTIM and Transducers Frequency Responses](#)

<sup>2</sup> The A-V circuitry attenuates frequencies above 1 kHz. Use of the 200155 transducer to obtain higher frequency information will be ineffective.

### A-V w/ AE Channels (with 200157)

Measurement Range	0 to 50 mm/s pk (0 to 2 in/s pk)
Over Range	63 mm/s pk (2.5 in/s pk)
Resolution	0.025 mm/s (0.001 in/s pk) nominal

Accuracy	±15% at 80 Hz
Frequency Response 1	
A-V	10 Hz to 1 kHz (600 cpm to 60,000 cpm) ± 20% (± 2.0 dB) 2. <a href="#">ProTIM and Transducers Frequency Responses</a>
AE	10 Hz to 500 Hz (600 cpm to 30,000 cpm) ± 20% (±2.0 dB) 3
Not OK Range:	Open transducer signal, power, or common is "Not OK". Shorted leads are "Not OK" except for SIG+ shorted to SIG- or common shorted to shield.

1 This Frequency response represents the System ProTIM & Transducer. For details on individual device frequency response, [ProTIM and Transducers Frequency Responses](#)

2 The A-V circuitry attenuates frequencies above 1 kHz. Use of the 200157 transducer to obtain higher frequency information will be ineffective. AE signals up to 10 kHz are processed at the ProTIM.

3 The 500 Hz filter has a 4-pole attenuation slope. The enveloped signal will range between 1Hz to 500 Hz.

**Table 2: ProTIM and Transducers Compatibility**

Device	200150	200155	200157
200250-01	Great	N/A	OK1
200250-05	OK2	Great	OK2
200250-06	OK 3	N/A	Great

1 The ProTIM does not offer AE capability and will only accept frequencies up to 1 KHz whereas 200157 will go up to 10 KHz.

2Lower transducer limit is 10 Hz, whereas 200155 will operate down to 3 Hz.

3 The ProTIM's AE circuit accepts frequencies up to 10 KHz, but 200150 operates only up to 1 KHz.

## Temperature Channels

Measurement Range	-18°C to +204°C (0°F to +400°F)
Resolution	0.07°C (0.12°F)

### Accuracy

K-Type TC	±8°C (±14°F), including ProTIM-C, thermocouple & lead wire error, maximum length of 6 meters.  Maximum temperature ramp rate: ±0.5°C/min.
RTD	±4.45°C (±8°F), RTD lead wire error not included
OK Range	-31°C to +213°C (-25°F to +415°F)
Not OK Condition	Temperatures outside the OK Range  Open RTD or thermocouple wires are "Not OK"

### RTD Compensation Coefficient Alpha in W/W/°C

European	0.00385
US Industrial	0.00392
Software Compensation	At host computer

## Rack Buffered Output Channels

Measurement Range	AC: 1 Vpp to 8 Vpp full scale DC: 0 to -20 Vdc (See Table 2)
-------------------	--

**Table 3: Input Signal and Range**

Input Signal	Full Scale	Overrange
LOAC_IN	1.6 Vpp	1.92 Vpp
HIAC_IN	8 Vpp	9.6 Vpp
DCGAP_IN	DC: -20 VDC AC: 1 Vpp	DC: -24 VDC AC: 5.3 Vpp
Resolution	AC: ±1% of full-scale value at 100 Hz DC: ±500 mV, absolute accuracy	
Frequency Response	10Hz to 3 KHz (+0 to -5%)	
Not OK Range	Input signal is out of range, Input signal miswired.	

## Process Variable Channels

Measurement Range	Current: +4 mA to +20 mA Voltage: +1 Vdc to 5 Vdc
Over Range	Current: <+3 mA or >+22 mA Voltage: <+0.8 Vdc or >+5.5 Vdc
Resolution	±1% of full-scale value Typical
OK Range	Current: Over +3.2 mA Voltage: Over 0.8 Vdc
Frequency Response	DC to 3 KHz

## Pressure Channels

Measurement Range	0 to 50 mV
Resolution	±8.5% of the transducer full-scale rating (transducer accuracy not included)

OK Range	1 Vdc to 3 Vdc Bias from transducer
Frequency Response	Less than 3 KHz

## Displacement Channels (with 330101/330103)

Input	Used with our 3300 XL 8 mm probe or 3300 5 mm probe and extension cable (5 metre system) only.
Output Voltage Range	-3.0 to 3.0 V (Over Specified linear range)
Transducer Linear Range	10 to 50 mils (0.254 to 1.27 mm)
Scale Factor	120 mV/mil +/-10%
Accuracy Over Gap Range	+/-1.2 mils @ mid-scale range.
Frequency Response	DC to 3 KHz (0 to 180,000 cpm).
Minimum Target size	15.2 mm (0.6 in) diameter (flat target)

Shaft Diameter:	<p>Minimum: 50.8 mm (2 in)          Recommended minimum: 76.2 mm (3 in)          Measurements on shaft diameters smaller than 50 mm (2 in) usually require close spacing of radial vibration or axial position transducers with the potential for their electromagnetic emitted fields to interact with one another (cross-talk), resulting in erroneous readings. Care should be taken to maintain minimum separation of transducer tips, generally at least 40 mm (1.6 in) for axial position measurements or 74 mm (2.9 in) for radial vibration measurements. Radial vibration or position measurements on shaft diameters smaller than 76.2 mm (3 in) will generally result in a change in scale factor. Consult Performance Specification 159484 for additional information.</p>
Not OK Range	Open/short transducer signal, Power or common is "Not OK".

### Environmental Limits

Operating Temperature	Standard: -40°C to +85°C (-40°F to +185°F)
<div style="border: 1px solid black; padding: 5px; margin: 5px 0;">  RTD, K-Type TC and Thermocouple ProTIM have a limited operating temperature of -25° C to +85° C.         </div>	
Storage Temperature	-40°C to +100°C (-40°F to +212°F)

Humidity	100% condensing on exposed surfaces. 100% noncondensing on surface inside conduit.
----------	---

 Apply DC4 grease on connector contacts to improve environmental performance and prevent corrosion.

Enclosure Type	Type 4
----------------	--------

### Mechanical

Housing Material	Powder-coated Aluminum
Weight	620 g (22 oz) not including conduit body
Dimensions	<a href="#">See Dimensional Diagram and Wiring Connection Details on page 14.</a>

### 200151 Transducer Cables

**Used to connect the 200150, 200150, and 2000157 transducers to the ProTIM-C.**

Operating Temperature	-20°C to +100°C (-4°F to +212°F).
-----------------------	--------------------------------------

 These cables may be used at lower temperatures down to -40°C (-40°F), if the cable is not allowed to move or flex. Flexing these cables at temperatures below -20°C (-4°F) may damage them.

Minimum Bend Radius	63.5 mm (2.5 in)
Construction	4-conductor (22 AWG) with foil shield and drain wire (100% coverage), polyvinyl chloride (PVC) outer jacket.

Connectors	Screw-on, 5-pin, keyed connector on the ProTIM-C end and a PT06F8-4S (or equivalent) on the transducer end. Connector coupling nuts consist of 1/2-20 UNF-threaded 2011 T3 aluminum or UV-stabilized black nylon. Contact material is gold-plated nickel-coated brass.
Classifications:	Cable assembly meets UL 2238. Cable meets IP67 ingress protection.

Voltage rating	300 Vrms
<b>Capacitance</b>	
Between Conductors	131 pF/m (40 pF/ft)
Between Conductor and Drain Wire	262 pF/m (80 pF/ft)

### 85033 Trendmaster SPA/TIM line cable

**Use to connect a SPA to the ProTIM-C.**

**For substitutions, reference guide 101206.**

Operating Temperature	-70°C to +200°C (-94°F to +392°F).
Conductors	4x 18 AWG stranded tinned copper 1x 18 AWG stranded copper, tinned overcoat uninsulated drain wire
Shielding	100% aluminum mylar foil out with helically applied drain wire 85% braided tinned copper

**Insulation**

Conductors	Fluoroethylene propylene (FEP) Teflon insulation 0.25 mm (0.010 in) thick
Outer	FEP Teflon insulation 0.38 mm (0.015 in) thick
Classifications	NEC article 725 class 3 UL Listed

## Compliance and Certifications

### FCC

This device complies with part 15 of the FCC Rules. Operation is subject to the following two conditions:

- This device may not cause harmful interference.
- This device must accept any interference received, including interference that may cause undesired operation.

### EMC

EN 61000-6-2 :2005

EN 61000-6-4:2007 +A1:2011

EMC Directive 2014/30/EU

### RoHS

RoHS Directive 2011/65/EU

### ATEX

EN 60079-0: 2012/A11:2013

EN 60079-11:2012

EN 60079-15:2010

EN 60079-28:2015 (DSM 149744 only)

EN 60079-31:2014 (TMGI 162459-01 only)

ATEX Directive 2014/34/EU

### Maritime

ABS 2009 Steel Vessels Rules

1-1-4/7.7,4-8-3/1.11.1,4-9-7/13

## Hazardous Area Approvals



For the detailed listing of country and product specific approvals, refer to the *Approvals Quick Reference Guide* (108M1756) available from [Bently.com](http://Bently.com).

TMGI (162459-01)	II (1) G [Ex ia Ga] IIC
	II(1) D [Ex ia Da] IIIC
	II 3 (1) G Ex nA [is Ga] IIC T4 Gc
	II 3 (1) D Ex tc [ia Da] IIIC T140°C Dc IP5X
	T4 @ Ta = -20°C to +65°C

## CSA/NRTL/C (Approval Options 05)

Installed with intrinsically safe zener barriers per drawing 112M7732	Ex ia IIC T4 Ga  Class I Zone 0: AEx ia IIC T4 Ga Class I, Div 1 Groups A, B, C & D Class II, Groups E, F & G  Class III  T4 @ -40°C [ Ta [+ 100° C (-40° F [ Ta [+212° F)
Installed without barriers per drawing 112M7732	Ex nA IIC T4 Gc  Class I Zone 2: AEx nA IIC T4 Gc Class I, Div 2 Groups A, B, C & D  T4 @ -40° C [ Ta [+ 100° C (-40° F [ Ta [+212° F)

## ATEX/IECEx

ProTIMs (200200 and 200250)	II 1 G Ex ia IIC T4 GC II 1 G Ex ia IIC T4 GC II 3 G Ex nA IIC T4 Gc  T4 @ Ta = -40°C to +100°C
Trendmaster DSM (149744)	II 3 G Ex nA IIC T4 GC  II 3 (3) G Ex nA [ic] IIC T4 Gc II 3 (3) G Ex nA op is [op is T4 Gc] IIC T4 Gc  T4 @ Ta = -20°C to +65°C



## Ordering Information



For the detailed listing of country and product specific approvals, refer to the *Approvals Quick Reference Guide* (108M1756) available from [Bently.com](http://Bently.com).

### ProTIM-C

#### 200250-AA-BB-CC-DD

##### A: Channel A Input Option

<b>0 1</b>	Acceleration to Velocity (200150)
<b>0 2</b>	K-Type Thermocouple (200125) <sup>1</sup>
<b>0 3</b>	2 or 3 Wire Pt. RTD
<b>0 4</b>	4 Wire Pt. RTD
<b>0 5</b>	Low Freq Accel-to-Velocity (200155)
<b>0 6</b>	Accel to Velocity w/ AE (200157)
<b>07</b>	Rack buffered Output
<b>08</b>	Process Variable
<b>09</b>	Pressure (120M1644)
<b>10</b>	Keyphasor (330101/330103)
<b>11</b>	Displacement (330101/330103)

##### B: Channel B Input Option

<b>0 1</b>	Acceleration to Velocity (200150)
<b>0 2</b>	K-Type Thermocouple (200125) <sup>1</sup>
<b>0 3</b>	2 or 3 Wire Pt. RTD
<b>0 4</b>	4 Wire Pt. RTD
<b>0 5</b>	Low Freq Accel-to-Velocity (200155)
<b>0 6</b>	Accel to Velocity w/ AE (200157)
<b>07</b>	Rack buffered Output

<b>08</b>	Process Variable
<b>09</b>	Pressure (120M1644)
<b>10</b>	Keyphasor (330101/330103)
<b>11</b>	Displacement (330101/330103)

**BB option availability is dependent on AA option chosen. Not all BB options are available with each AA option.**

##### C: Approvals

<b>0 1</b>	None
<b>0 5</b>	Multiple Approvals

##### D: Conduit Body Style

<b>0 0</b>	No conduit body
<b>0 1</b>	Appleton Style C body, malleable iron
<b>0 2</b>	Appleton Style E body, malleable iron
<b>0 3</b>	Appleton Style C body, aluminum
<b>0 4</b>	Appleton Style E body, aluminum
<b>0 5</b>	Weatherproof housing mount

<sup>1</sup> The 200125 is the recommended Trendmaster sensor for temperature measurements when the range of a K-type thermocouple is adequate. We do not recommend the use of other K-type thermocouples due to the unique electrical isolation requirements of the Trendmaster system, and we highly recommend the use of only non-grounded RTDs and non-grounded tip thermocouples to prevent ground loops. Failure to comply may result in Not OK or NO DATA conditions, inaccurate readings, or ProTIM-C damage. Consult Bently Nevada for further information.

## Transducer Cable (for use with 200150, 200150, and 200157 accelerometers)

### 200151-AA-BB-CC

Use the 200151 with the 200250 ProTIM only with applications using either a 142485 Housing Cable Adapter or a 141887 Conduit Cable Adapter

#### A: Cable Length:

<b>2 0</b>	2.0 metre (6.6 feet) cable
<b>4 0</b>	4.0 metre (13.1 feet) cable
<b>6 0</b>	6.0 metre (19.7 feet) cable

#### B: Armor Option:

<b>0 2</b>	Standard cable, unarmored.
<b>0 3</b>	Stainless steel over braid (armored) cable

#### C: Nut Option:

<b>0 0</b>	Standard aluminum coupling nut
<b>0 2</b>	Nylon coupling nut
<b>1 0</b>	Knurled aluminum coupling nut

C01, environmental boot option, is no longer available and is not necessary for use with all three existing stainless steel accelerometers, but may be used with previous plastic 200150 sensors.

## Transducer Cable

### 120M1648-AA for use with 120M1644 Pressure Transducer.

#### A: Cable Length:

<b>0 2</b>	2.0 meter (6.56 feet) cable
<b>0 4</b>	4.0 meter (13.12 feet) cable

<b>0 6</b>	6.0 meter (19.69 feet) cable
<b>0 9</b>	9.0 meter (29.53 feet) cable

## Pressure Transducer

### 120M1644-AAAA

#### A: Pressure rating

<b>0050</b>	0 to 50 PSI SG
<b>0500</b>	0 to 500 PSI SG
<b>2000</b>	0 to 2000 PSI SG

## Accessories

01620085	Extra Terminal Plugs. For SPA line connection. 3 terminal plugs provided with each ProTIM-C module
149326-01	The 200151 Accel Cable Environmental Boot Field Installation Kit. Contains everything needed to install the boot in the field. It includes 10 sets of boots and clamps, silicone lubricant, easy-to-use installation tool, and an instruction sheet. You can purchase additional boots and clamps separately (see part number below). The kit is not compatible with armored cables and only compatible with older, plastic versions of accelerometers; not compatible with existing stainless steel accelerometers.
04500006	Dow Corning 4, Electrical Insulating Compound (5.3 Oz).
03814231	Compression Fitting. For 1-inch conduit body hubs. Seals for cables when installing ProTIM-C modules without conduit.
85033-02-00	300 Meter (1000 ft) Cable. For TIM line.

85033-01-00	150 Meter (500 ft) Cable. For TIM line
162454	Dust Cap. For temperature channel connectors.
04400000	Dust Cap. For accelerometer channel connectors.
141888	Hardware Mounting Kit. For mounting ProTIM-C modules to weather-proof housings
03810116	Red Silicone Rubber Gasket. Use between ProTIM-C and weatherproof housing.
163996-01	ProTIM-C Conduit Gasket/Cable Seal Installation Kit. Consists of a black silicone rubber gasket/seal, three nylon hose clamps, electrical insulating compound, and instructions for installation.
162438-01	Thermocouple and RTD Connector. With smaller cable crimp seal.
02180005	Jumpers. For the ProTIM-C Thermocouple or RTD terminals.

For more information on this product, please refer to:

Trendmaster ProTIM-C User Guide (document 161934) and 149744 Trendmaster Dynamic Scanning Module Datasheet (document 149831).

## Installation

In order to accommodate the wide range of customer installation needs, a selection of mounting hardware is available to allow a variety of installation options. In addition, replacement parts are available for most hardware components. The following table lists accessories for use with ProTIM-C modules, Transducers, and some Trendmaster installation hardware.

**Table 1: Installation Hardware**

200150-AA (See transducer datasheet 164986 for mounting options)	General-purpose, case-mounted seismic transducer designed specifically for use with the Trendmaster systems.
200157-AA (See transducer datasheet 164986 for mounting options)	High frequency, case mounted seismic transducer designed specifically for use with Trendmaster systems.
200151-AA-BB-CC (see 200200 ProTIM-R datasheet 163662)	Accelerometer Extension Cable; Two Connectors Armor is stainless steel braid.
40113-02	3300XL Connector Protector Kit. Protection for 3300XL probe connectors to minimize corrosion and other environmental damage.
200152-AA-BB (see 200200 ProTIM-R datasheet 163662)	Accelerometer Extension Cable; One Connector
English Thread: 330101 Metric Thread: 330103 (See transducer datasheet for configuration options)	3300XL 8 mm Proximity Transducer System. Applicable ProTIM devices use 3300XL transducers with 5 meter total system length.

136806-01	Conduit T Tim (Allows branching of TIM line in conduit)	85717-01	Standard (non-I.S.) Weatherproof Housing. Polyester W/P Housing, Div 2, Type 4X, 4 ProTIM-R Max
141887-01	Conduit Cable Adapter; Single	00500128	Extra terminal plugs for transducer connection to ProTIM-R module. Each ProTIM-R is provided with 2 terminal plugs
141887-02	Conduit Cable Adapter; Double	02810005	Jumpers for the 2 awire RTD ProTIM-R channels
142485-01	Housing Cable Adapter	03814237	Hub. 12 mm (1/2 in.) rigid conduit hub for intrinsically safe installations
164045	Female TIM Line Connector	03817040	Bushing, ground, 0.2 inch for
164046	Male TIM Line Connector	03839129	Conduit Fitting. 12 mm (1/2 in.) NPT
164532	TIM Line T Connector (Branches the TIM Line with the ProTIM-R; fits in the Female TIM Line connector slot)	03839240	Cable Seal. 1/4-in NPT, use with TIM line cable
85033-01-00	Trendmster TIM cable. 150 m (500 FT)	03839241	Cable Seal. 1/4 -in NPT, use with Velocity, RTD, Thermocouple
85033-02-00	Trendmster TIM cable. 300 m (1000 ft)	03839242	Cable Seal. 1/4 -in NPT, use with Displacement Probe Cable
88312-01	I.S. Housings (Type 4) Fiberglass Polyester. I.S. Polyester W/P Housing, Div 1, Type 4X, 4 ProTIM-R Max	03839243	Cable Seal. 1/2 -in NPT, use with Armored Probe cable
88313-01	I.S. Housings (Type 4) Fiberglass Polyester. I.S. Polyester W/P Housing, Div 1, Type 4X, 2 ProTIM-R Max	03830490	O-ring. 1/2-in Square Cut for 1/2 -in NPT fittings
88314-01	I.S. Stainless Steel (SST) Housing. I.S. SST W/P Housing, Div1, Type 4X, 4 TIMs Max	03880243	Thread Seal. 1/4 -in for 1/4 NPT fittings
88315-01	I.S. Stainless Steel (SST). I.S. SST W/P Housing, Div1, Type 4X, 2 TIMs Max	04500006	Electrical Grease. Dow Corning 4, Electrical Insulating Compound (5.3 Oz)
85716-01	Standard (non-I.S.) Weatherproof Housing. Polyester W/P Housing, Div 2, Type 4X, 2 ProTIM-R Max		

## Graphs and Figures

**Table 1: Channel Types Cross-compatibility**

			Channel A																	
			Acceleration to Velocity	K-Type Thermocouple	2 or 3 Wire Pt. RTD	4 Wire Pt. RTD	Low Freq Accel-to-Velocity	Accel to Velocity w/AE	Rack buffered Output	Process Variable	Pressure	Displacement								
			01	02	03	04	05	06	07	08	09	11								
<p>The <b>200200 dual-input proTIM-R</b> (DIN rail mount) provides 2 channels of measurement.</p> <p>The <b>200250 dual-input proTIM-C</b> (Conduit mount) provides 2 channels of measurement.</p>																				
Channel B	Acceleration to Velocity	01	OK																	
	K-Type Thermocouple	02	OK	OK			OK	OK												
	2 or 3 Wire Pt. RTD	03	OK		OK		OK	OK												
	4 Wire Pt. RTD	04	OK			OK	OK	OK												
	Low Freq Accel-to-Velocity	05	OK				OK	OK												
	Accel to Velocity w/AE	06						OK												
	Rack buffered Output	07								OK										
	Process Variable	08									OK									
	Pressure	09										OK								
	Displacement	11																		OK

Note: All dimensions in millimetres (inches) except as noted.

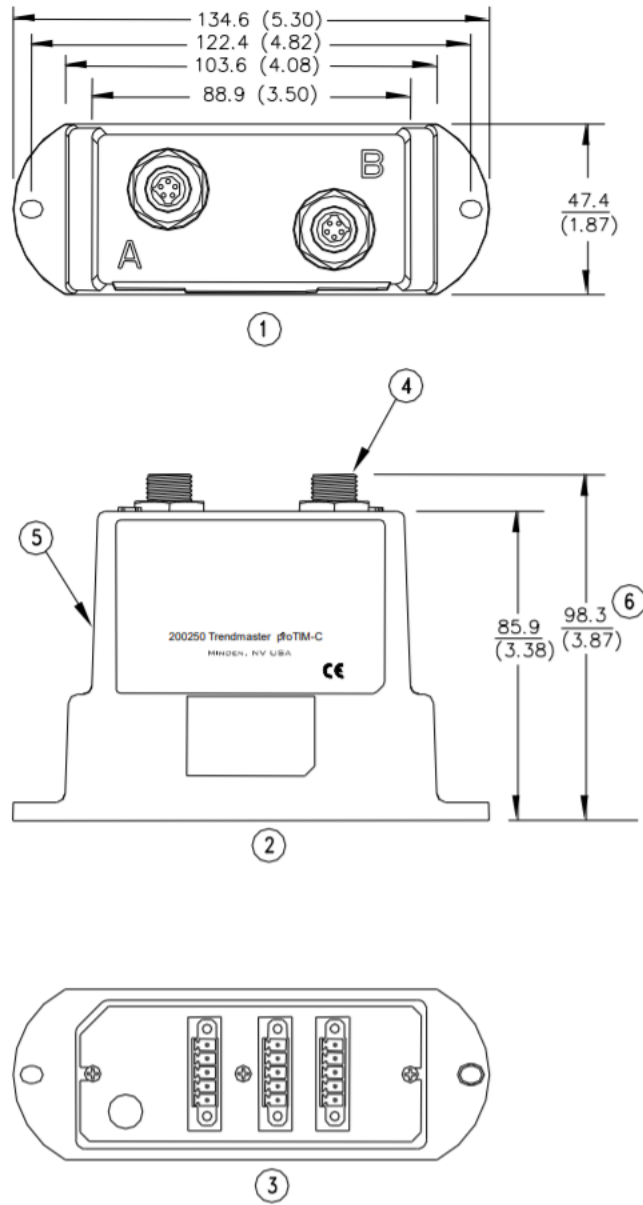

1. Top view
2. Front view
3. Bottom view
4. Powder-coated aluminum housing
5. Allow 127 mm (5 in) for total height with connector and cable bend

**Figure 1: Dimensional Diagram and Wiring Connection Details**

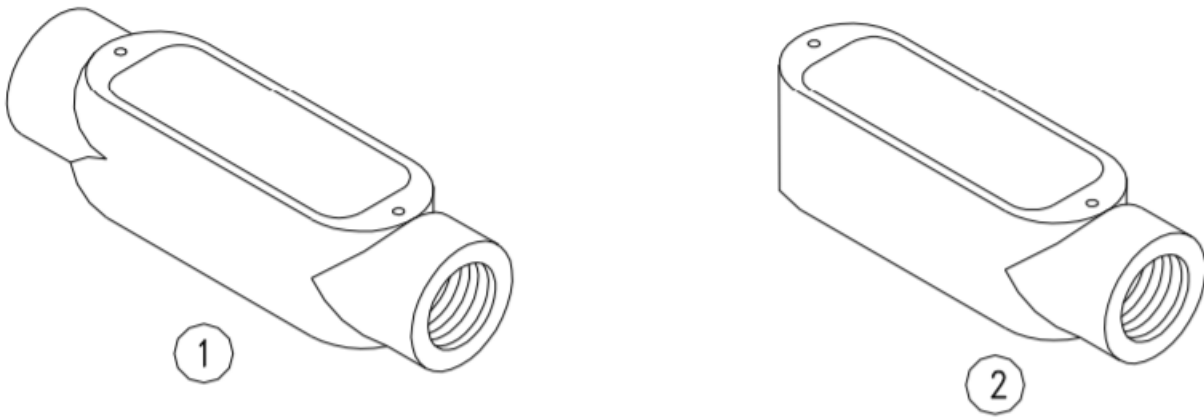

- 1. Style C conduit body
- 2. Style E conduit body

**Figure 2: Conduit Body Styles Provided with the ProTIM-C**

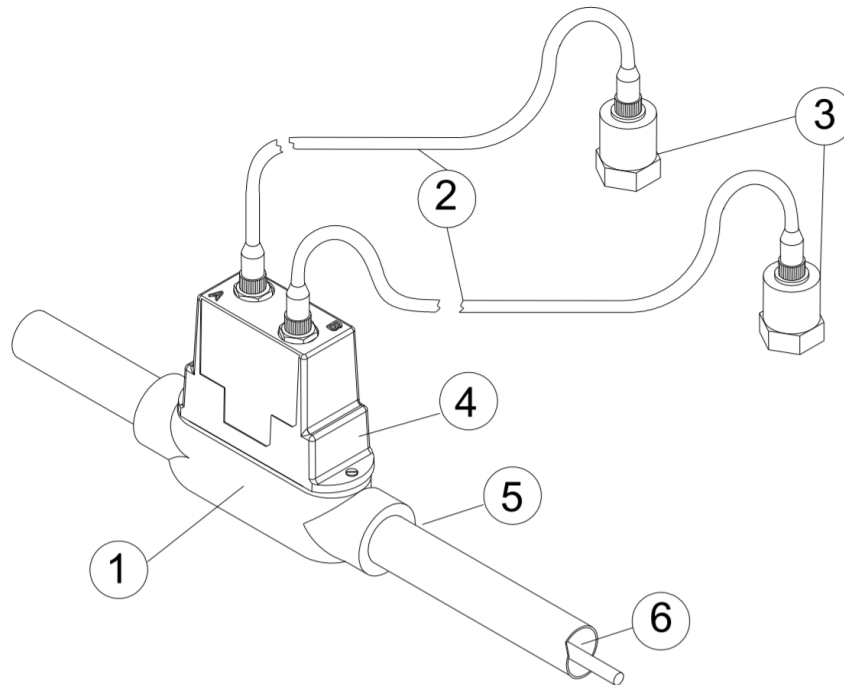

- 1. Style C conduit body
- 2. Transducer cables
- 3. Transducers
- 4. ProTIM-C module
- 5. Rigid conduit
- 6. SPA line

**Figure 3: Installed ProTIM-C in Style C Conduit Body**

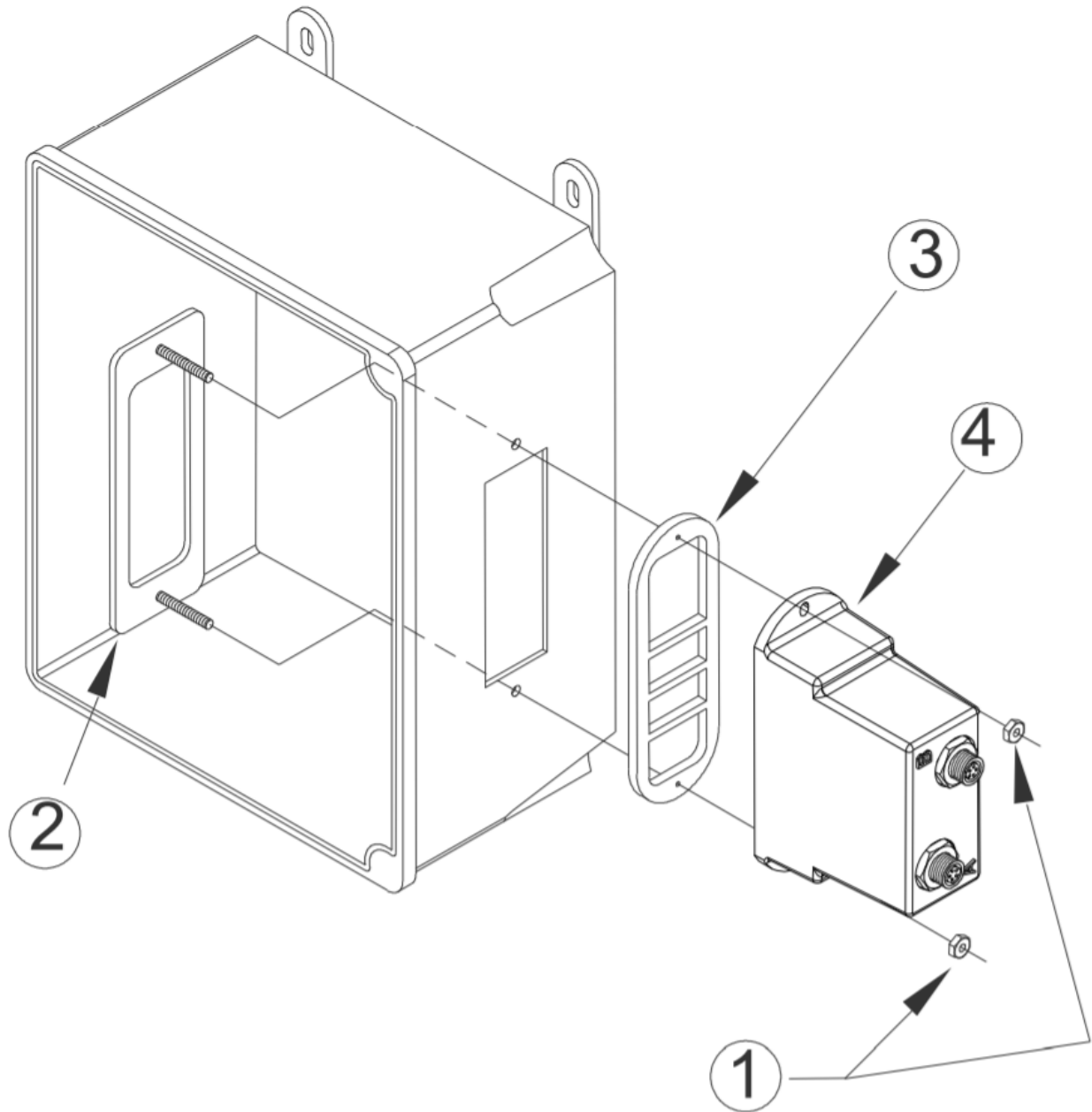

- 1. Retention nuts (2 places)
- 2. Reinforcing plate
- 3. Gasket
- 4. proTIM-C module

**Figure 4: Installed ProTIM-C Module with Weatherproof Housing**



Copyright 2021 Baker Hughes Company. All rights reserved.



Bently Nevada, Keyphasor, Trendmaster and Orbit Logo are registered trademarks of Bently Nevada, a Baker Hughes Business, in the United States and other countries. The Baker Hughes logo is a trademark of Baker Hughes Company. All other product and company names are trademarks of their respective holders. Use of the trademarks does not imply any affiliation with or endorsement by the respective holders.

Baker Hughes provides this information on an "as is" basis for general information purposes. Baker Hughes does not make any representation as to the accuracy or completeness of the information and makes no warranties of any kind, specific, implied or oral, to the fullest extent permissible by law, including those of merchantability and fitness for a particular purpose or use. Baker Hughes hereby disclaims any and all liability for any direct, indirect, consequential or special damages, claims for lost profits, or third party claims arising from the use of the information, whether a claim is asserted in contract, tort, or otherwise. Baker Hughes reserves the right to make changes in specifications and features shown herein, or discontinue the product described at any time without notice or obligation. Contact your Baker Hughes representative for the most current information.

The information contained in this document is the property of Baker Hughes and its affiliates; and is subject to change without prior notice. It is being supplied as a service to our customers and may not be altered or its content repackaged without the express written consent of Baker Hughes. This product or associated products may be covered by one or more patents. See [Bentley.com/legal](https://www.bentley.com/legal).

1631 Bently Parkway South, Minden, Nevada USA 89423  
Phone: 1.775.782.3611 (US) or [Bentley.com/support](https://www.bentley.com/support)  
[Bentley.com](https://www.bentley.com)