



Application note

Verifying accuracy of in-line flowmeters in waste-water treatment facility

Specifications:

- Temperature: ambient
- Flow range: 0 to 250 L/min (typical)
- Pipe size: 2 to 10 in
- Materials: PVC, carbon steel, stainless steel, fiber glass
- Liquids: water with 5 to 10% maximum entrained solids, perchloroethane, and other chemical/process wastes



Sample installation of a Panametrics portable ultrasonic flowmeter on a 4" PVC pipe

Application

Many industrial plants have on-site water treatment facilities. Different departments or divisions at the plant send their waste water or chemical by-products to the water treatment facility for handling, purification or filtration. The load of waste water, in particular, is of critical importance in these times of environmental concern because waste water is usually discharged to a local water basin.

Most facilities use in-line flowmeters to monitor the volumetric load of waste water or chemical byproducts as they are fed to the waste treatment facility. The accuracy of these flowmeters must be continuously verified for purposes of legal accountability.

Background

A major semiconductor manufacturer has an on-site waste treatment facility. Each department at the plant has its own discharge line into the facility. There are over twenty lines, all of which run through a concourse to the remote waste treatment facility. The discharge lines range from 2 to 10 in and are constructed of a variety of materials ranging from PVC to stainless steel. Various permanently installed flowmeters monitor the flow on each discharge line just before the point where the discharge lines enter the waste treatment facility.

The volumetric flow rate of the discharge lines is monitored on a continuous basis. The waste treatment facility bills each department at an appropriate usage rate for the amount it discharges. This motivates each department to optimize its processes so as to produce the least waste discharge possible.

Problem

There is a need for an easy-to-installed portable flowmeter to verify the accuracy and function of the permanently installed flowmeters. The volumetric flow must be recorded over time. This data can then be compared to the customer's data as derived from a recording device or digital acquisition control system. The calibration, accuracy and function of the in-line flowmeter can thus be verified.

How previously handed

Previously, there was no way to verify the performance of the permanently installed flowmeters. While various types of portable flowmeters had been considered, they were considered undesirable because they were bulky, required an external recording device, or were too costly.

Advantages

Using the Panametrics Portable Ultrasonic Flowmeter, the parameters for various discharge pipes can be permanently programmed into the flowmeter memory as site information, thus minimizing set-up time and effort. The portable ultrasonic flowmeter can operate for up to eight hours on its rechargeable battery. For longer periods of continuous testing, it can be plugged into a standard electrical outlet. The portable ultrasonic flowmeter can log data on a continuous basis. After the testing is complete, the log can be uploaded to a computer using a Panametrics instrument interface software package (supplied separately). The data can then be plotted and compared to data generated by the permanently installed flowmeter.

Also the portable flowmeter can be used in case of emergency where an in-line flowmeter fails or is not in service.

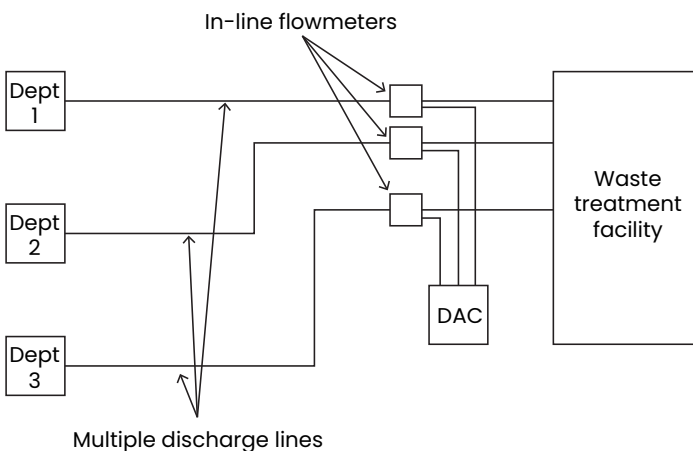

Panametrics, a Baker Hughes business, provides solutions in the toughest applications and environments for moisture, oxygen, liquid and gas flow measurement.

Experts in flare management, Panametrics technology also reduces flare emissions and optimizes performance.

With a reach that extends across the globe, Panametrics' critical measurement solutions and flare emissions management are enabling customers to drive efficiency and achieve carbon reduction targets across critical industries including: Oil & Gas; Energy; Healthcare; Water and Wastewater; Chemical Processing; Food & Beverage and many others.

Join the conversation and follow us on LinkedIn
[linkedin.com/company/panametricscompany](https://www.linkedin.com/company/panametricscompany)

Equipment

CPT-type transducers together with a universal clamping fixture provide noninvasive operation on all kinds of pipe materials. The following features are of particular interest in this application:

- Portability
- Battery-powered operation
- 1 to 2% accuracy
- Data logging capability
- PC interface capability

Installation

The portable ultrasonic flowmeter is ideal for this type of application because it is easy to install on a wide variety of process pipes of many different materials. When demonstrated on a 3 in PVC pipe with waste water containing 5 to 10% entrained solids, the PT868 successfully tracked a batch dump from the process where the flow rate changed from 250 L/min. The data was then plotted using the graphic-display mode of the PT868. When compared to the data from the inline magnetic flowmeter, recorded by the customer's DAC system, a perfect correlation with 1% accuracy was revealed.