

SEIFERT

# ERESCO 300 MF4-R

Portable air-cooled 300 kV X-ray machine for radioscopic applications with high magnification

The ERESKO 300 MF4-R combines the advantage of a high voltage range up to 300 kV with a by a factor 3 smaller focal spot compared to Waygate Technologies conventional ERESKO MF4 radiation units.

This offers excellent penetration, sharper results and shorter exposures as well as geometric magnification inspection to facilitate higher productivity and quality in day-to-day inspection routines.

The X-ray tube head consists of a sturdy metal-ceramic X-ray tube and high voltage generator integrated into a rugged compact housing. The air-cooled 300 KV/ 900 W end-grounded X-ray tube is thermally protected for extended life.

The high voltage generator generates high-stability constant potential voltage at higher efficiency than conventional line frequency equipment.

The unit offers factor 3-5 times exposure time reduction for radioscopic applications respectively for applications with CR/Film where geometric enlargement is required.

The performance of the X-ray tube and the high voltage generator is continuously monitored for protection and operational safety. An on-board real time clock facilitates fully automatic warm-up routines for optimized and time-saving tube conditioning. The flexible connecting cable is heavy-duty and light weight.

The ERESKO series can also be controlled by PC or laptop and is compatible with the Waygate Technologies software Rhythm Insight RT.

## Additional Features

- Water / dust resistant in accordance with protection class IP65
- Extended operating range from 10 kV to 300 kV enables flexible use
- Gas insulated high voltage section reduces size & weight
- End-grounded, Be-window, metal-ceramic X-ray tube
- DC voltage operation
- Modern power electronics provides high stability
- On-board real time clock supports fully automatic warm-up
- Small 1 mm focal spot for sharper results and higher geometric magnification
- Large 30° × 60° emergent beam
- Optimized air-flow cooling for efficient heat dissipation
- 100 % duty cycle at 30° Celsius (86° F) for max. operation time 1h
- Built-in fail-safe warning lamp
- CE certification according to EMC and Low Voltage Directives
- French Standard NFC 74 100 compliance requested
- BfS certification (PTB approval requested)
- Based on the design of ERESKO 65 MF4, duty cycle and robustness
- Improved image resolution for field inspection with geometric magnification and use of portable digital detectors like DXR250C-W and DXR250U-W
- Produced under ISO 9001 certified quality management system

## Standard Delivery Scope

ERESCO generator unit from high voltage generator and X-ray tube or optionally as a system with "ERESCO MF4 Control" control unit



# Technical Data

|   |  |
|---|--|
| X-ray tube type   | 300 kV metal-ceramic with Tungsten (W) anode           |
| kV range  | 10 - 300 kV (acc. to rating chart)                     |
| Target angle  | 15°  |
| Inherent filtration                                       | 0.8 mm ± 0.1 mm, Be                                    |
| Emergent beam   | 30° × 60°, elliptical                                  |
| Focal spot size (EN 12 543)                               | 1.0 mm (EN 12543)                                      |
| Tube current  | 0.5 - 6 mA (3.0 mA /300 kV)                            |
| Anode temperature, max.                                   | 100° C   |
| Current and voltage stability                             | ± 1 %  |
| Continuous rating   | 900 W  |
| Duty cycle ( $\delta_{Um\text{g}} = 30^\circ \text{ C}$ ) | 100 % (up to 60 min continuous operation)              |
| Power input, max.   | 2.0 kVA  |
| Weight  | 40 kg (88.2 lbs)<br>37.5 kg (82.7 lbs) (without rings) |
| Tube head diameter  | 290 mm (11.42")<br>225 mm (8.87") (without rings)      |
| Protection class  | IP65   |
| Operating Temperature                                     | -20° C to +50° C                                       |
| Storage Temperature                                       | -30° C to +80° C                                       |

## Options

- Carrying cradle
- Diaphragm / collimator attachments
- Laser centering device
- Transport and positioning cart
- Fail-safe flashing warning lamp
- Stands and mounting kits
- Aluminium transport box

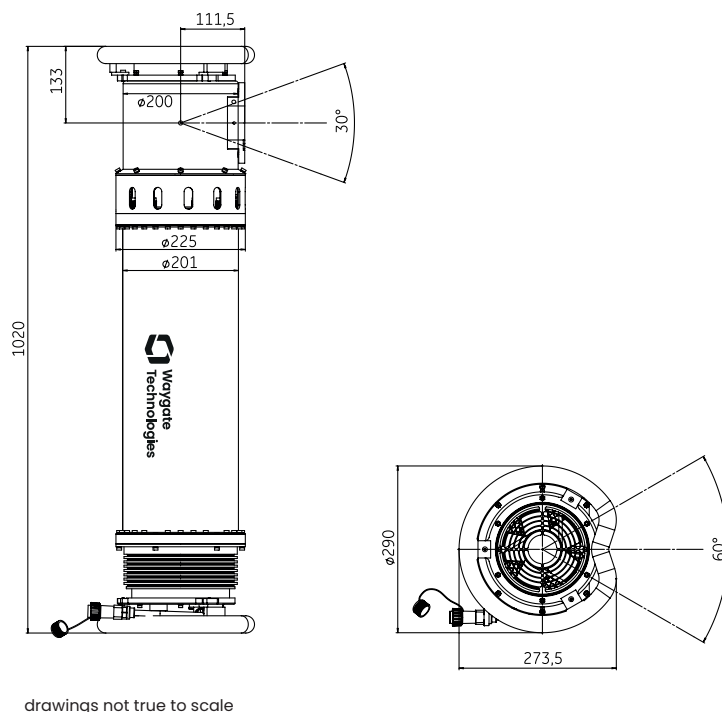
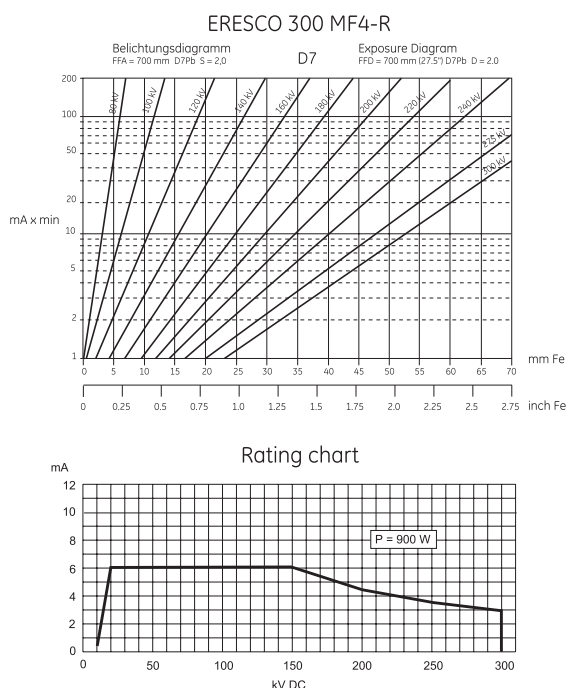

Waygate Technologies  
 Bogenstr. 41 • 22926 Ahrensburg / Germany  
 Tel.: +49 4102 807 0 • Fax: +49 4102 807 189 • E-Mail: xray.info@bakerhughes.com

Copyright 2020 Baker Hughes Company. This material contains one or more registered trademarks of Baker Hughes Company and its subsidiaries in one or more countries. All third-party product and company names are trademarks of their respective holders.

BHFF30225\_EN (09/2020)

**Baker Hughes**

waygate-tech.com