

162459 Trendmaster Galvanic Isolator (TMGI)

Datasheet

Bently Nevada Machinery Condition Monitoring

162513 Rev. G

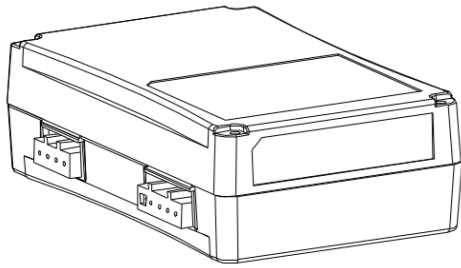

Description

The Trendmaster Galvanic Isolator enables the Trendmaster system to connect to intrinsically safe transducer installations without the need for safety barriers or the need to specify, install and maintain a high integrity IS earth. The Trendmaster Galvanic Isolator provides an interface between Trendmaster scanning hardware, and all associated Programmable Transducer Interface Modules (ProTIMS) located in a hazardous area.

- The Trendmaster Galvanic Isolator is powered from an external power supply which enables several Galvanic Isolators to be connected in parallel to one TIM line from DSM or SPA.
- Each Galvanic Isolator can interface and power up to at most 32 ProTIM with maximum cable length determined by the area of use.



Specifications

All values are specified over the full operating temperature range unless stated otherwise. All voltages are specified with respect to COM. References to ProTIMs relate to ProTIM-R and ProTIM-C. References to ProTIM relate to the Trendmaster 2000 Programmable Transducer Interface Modules.

External Power Input

Nominal Input Voltage	+ 24 V \pm 5%
Maximum Current Draw	100 mA

Power Dissipation

Including power supply to 32 ProTIMs and associated transducers	2.5 Watts @ +24 V, Typical
---	----------------------------

Environmental Specification

Operating Temperature Range	-20 to +65 °C
Storage Temperature Range	-40 to +85 °C
Relative Humidity	100 % condensing, non-submerged, power on when installed in a weatherproof housing.

Physical

Weight	0.25 Kg (0.55 lb)
Dimensions	94 mm x 150 mm x 45 mm (3.7" x 5.9" x 1.77")
Mounting	DIN Rail weatherproof housing.

AC Performance

Accuracy	\pm 1 %
Noise Floor	\pm 0.5% Trendmaster full-scale
Bandwidth	1% dc to 10 kHz
ac Phase	+ 3.0° @ 600 Hz absolute \pm 1.5° @ 600 Hz unit-to-unit skew *
	* For phase-critical measurements all measured signals should be connected through isolators to preserve phase.

DC Performance

Accuracy	\pm 1 % or 15 mV whichever is the greater
----------	---

Inputs

Safe area connection to the following Trendmaster Host scanning hardware.

Dynamic Scanning Module (DSM)	149744 Maximum of Four Galvanic Isolators connected to each TIM line from DSM or SPA.
-------------------------------	--

Outputs

Hazardous area connection to the following Intrinsically Safe Transducer Interface Module types:

200250	ProTIM-C
200200	ProTIM-R

Number of TIMs

A maximum number of 32 ProTIMs are allowed to connect to one Galvanic isolator.

Compliance and Certifications

Hazardous Area Approvals

For the detailed listing of country and product specific approvals, refer to the *Approvals Quick Reference Guide* (108M1756) available from Bently.com.

CSA/NRTL/C (Approval Options 05)

Installed with intrinsically safe zener barriers per drawing 112M7732	<p>Ex ia IIC T4 Ga</p> <p>Class I Zone 0: AEx ia IIC T4 Ga Class I, Div 1 Groups A, B, C & D Class II, Groups E, F & G</p> <p>Class III</p> <p>T4 @ -40° C [Ta [+ 100° C (-40° F [Ta [+212° F)</p>
Installed without barriers per drawing 112M7732	<p>Ex nA IIC T4 Gc</p> <p>Class I Zone 2: AEx nA IIC T4 Gc Class I, Div 2 Groups A, B, C & D</p> <p>T4 @ -40° C [Ta [+ 100° C (-40° F [Ta [+212° F)</p>

ATEX/IECEX

ProTIMs (200200 and 200250)	
	 II 1 G Ex ia IIC T4 GC II 3 G Ex nA IIC T4 Gc T4 @ Ta = -40°C to +100°C

Trendmaster DSM (149744)	
	 II 3 G Ex nA IIC T4 GC II 3(3) G Ex nA [ic] IIC T4 Gc II 3(3) G Ex nA op is [op is T4 Gc] IIC T4 Gc T4 @ Ta = -20°C to +65°C

TMGI (162459-01)	
	 II (1) G [Ex ia Ga] IIC II(1) D [Ex ia Da] IIIC II 3 (1) G Ex nA [is Ga] IIC T4 Gc II 3(1) D Ex tc [ia Da] IIIC T140°c Dc IP5X T4 @ Ta = -20°C to +65°C

Ordering Information



For the detailed listing of country and product specific approvals, refer to the *Approvals Quick Reference Guide* (108M1756) available from Bently.com.

Trendmaster Galvanic Isolator

162459

01	Multi-Approvals (ATEX, CSA, IECEx)
----	---------------------------------------

Including connectors required for installation.

Accessories

02200627	Power Supply
162222-01	Weatherproof Housing
164046	TIM Line Connector from SPA
164045	TIM Line Connector to TIMs
164314	Power Supply Connector
Bently_ Manuals	Customer DVD containing all Bently Manuals, FWD, App Notes, and Install Guides in all available languages

Graphs and Figures

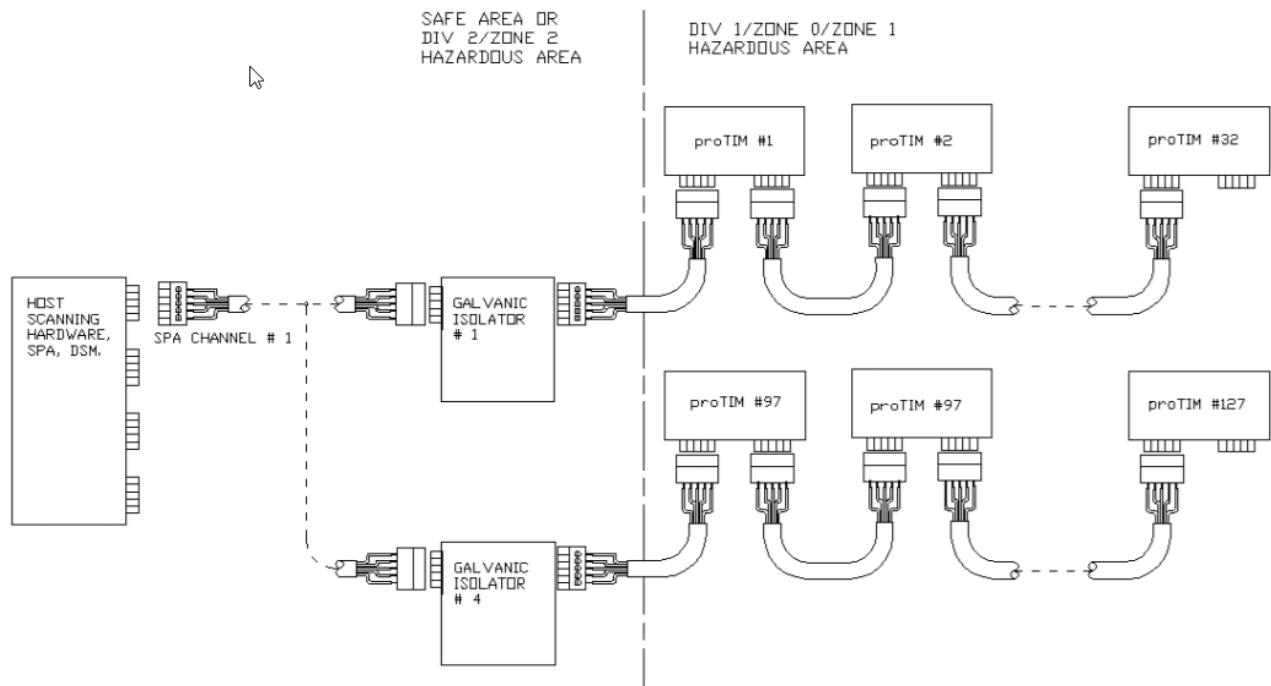

Reference drawing 162521 for the maximum number of 32 ProTIMs allowed to connect to one Galvanic Isolator

Figure 1: System Installation

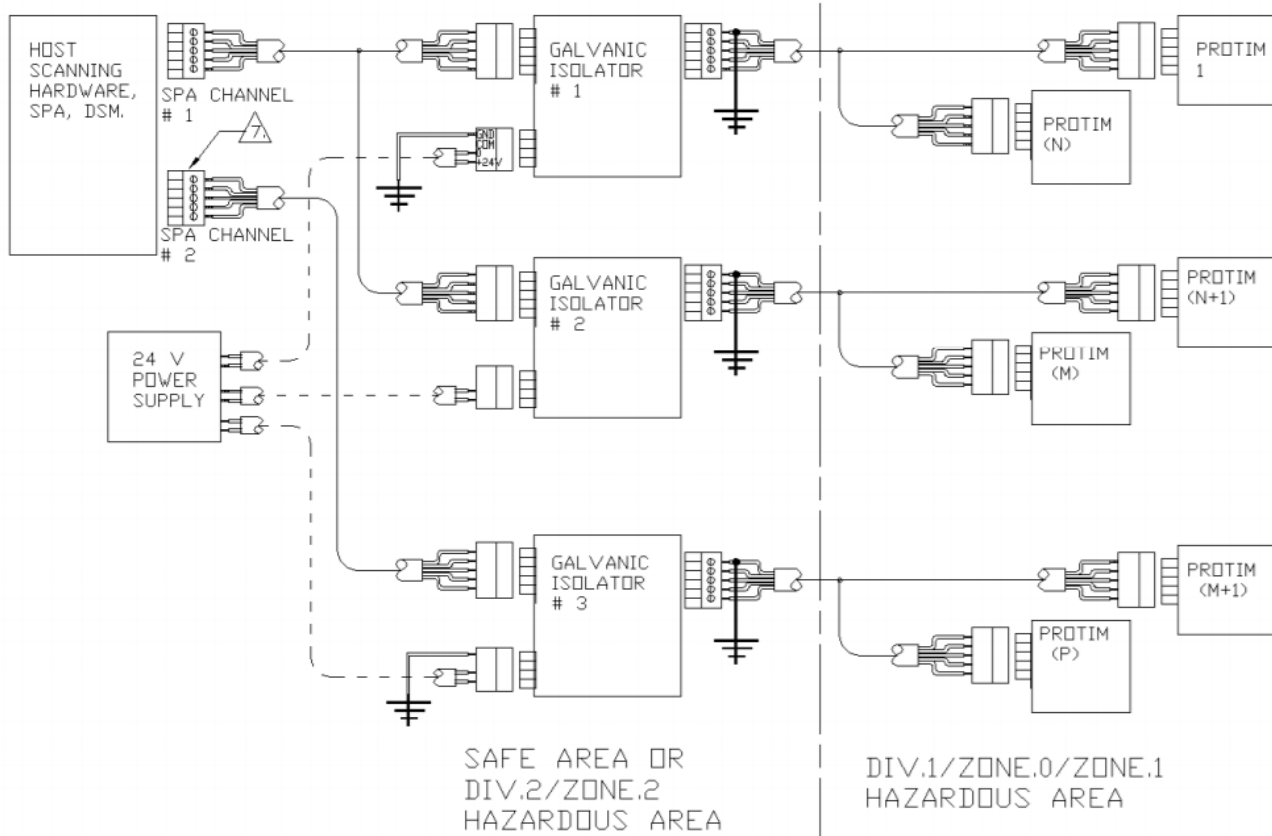
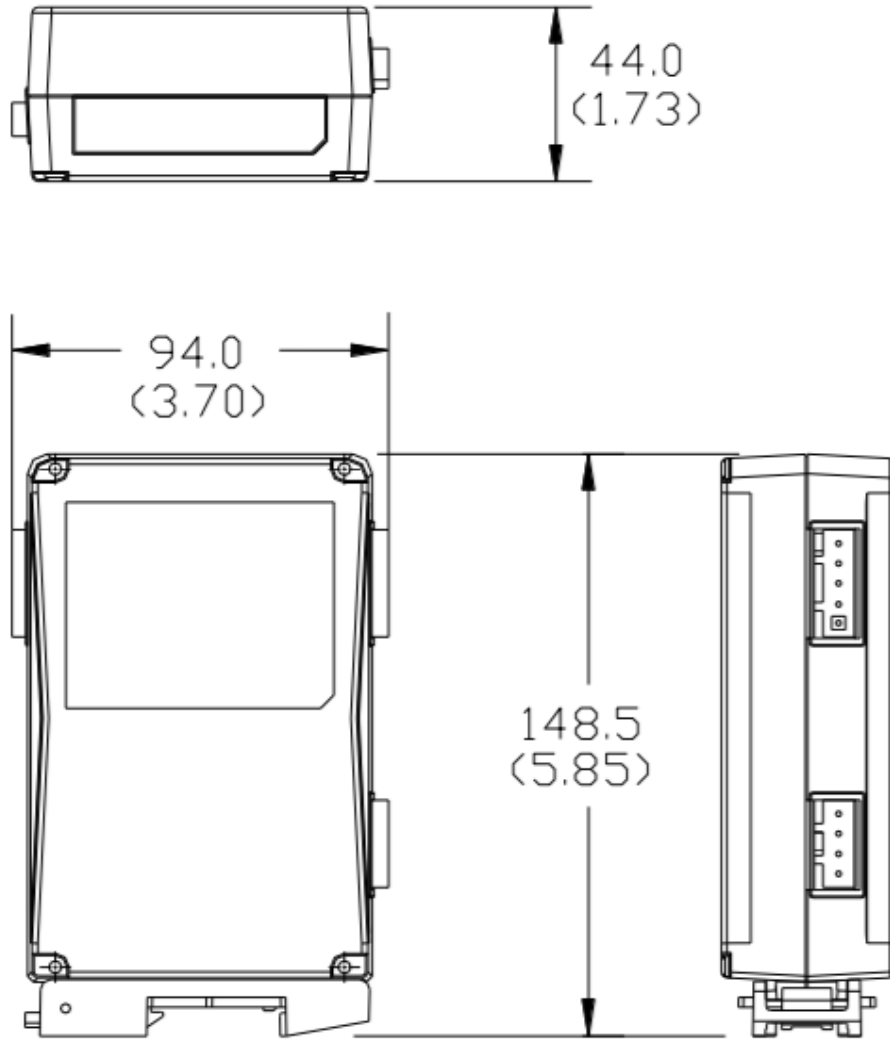

Figure 2: Grounding

- * Each SPA channel must connect to instrument ground at one Galvanic Isolator.
- * Each Galvanic Isolator's IS shield must connect to IS ground.
- * Refer to BN Documents 162521 and 166857 for more information.

Table 1: Connector Pin Assignments

Pin #	Power Supply (SAFE)	TIM Line Connected to DSM or SPA (SAFE)	TIM Line Connected to proTIMs (HAZ)
1	+24V	SHIELD	TIM SIG+ (GRN)
2	0V	SPA PWR (RED)	TIM SIG- (WHT)
3	GND	SPA COM (BLK)	TIM COM (BLK)
4	GND	SPA SIG- (WHT)	TIM PWR (RED)
5	N/A	SPA SIG+ (GRN)	SHIELD



Dimensions are in millimeters (inches)

Figure 3: Trendmaster Galvanic Isolator

Copyright 2021 Baker Hughes Company. All rights reserved.



Bently Nevada, Trendmaster and Orbit Logo are registered trademarks of Bently Nevada, a Baker Hughes Business, in the United States and other countries. The Baker Hughes logo is a trademark of Baker Hughes Company. All other product and company names are trademarks of their respective holders. Use of the trademarks does not imply any affiliation with or endorsement by the respective holders.

Baker Hughes provides this information on an "as is" basis for general information purposes. Baker Hughes does not make any representation as to the accuracy or completeness of the information and makes no warranties of any kind, specific, implied or oral, to the fullest extent permissible by law, including those of merchantability and fitness for a particular purpose or use. Baker Hughes hereby disclaims any and all liability for any direct, indirect, consequential or special damages, claims for lost profits, or third party claims arising from the use of the information, whether a claim is asserted in contract, tort, or otherwise. Baker Hughes reserves the right to make changes in specifications and features shown herein, or discontinue the product described at any time without notice or obligation. Contact your Baker Hughes representative for the most current information.

The information contained in this document is the property of Baker Hughes and its affiliates; and is subject to change without prior notice. It is being supplied as a service to our customers and may not be altered or its content repackaged without the express written consent of Baker Hughes. This product or associated products may be covered by one or more patents. See [Bentley.com/legal](https://www.bentley.com/legal).

1631 Bently Parkway South, Minden, Nevada USA 89423
Phone: 1.775.782.3611 (US) or [Bentley.com/support](https://www.bentley.com/support)
[Bentley.com](https://www.bentley.com)