



# PanaFlow HT

## Panametrics ultrasonic SIL flow meter for liquids

### Applications

PanaFlow HT is a SIL-rated flow meter used for flow measurement of liquids in either nominal or extremely high or low process temperatures. It is the first ultrasonic flow meter to receive SIL (Safety Integrity Level) certification. As a safety flow meter, or coker flow meter, the PanaFlow HT SIL flow meter is designed for use in safety-critical applications where reliability ensures reduction in risk to personnel, to plant assets, to the environment and to corporate reputation. It also brings advantages to any non-safety critical application where reliable ultrasonic flow measurement is required.

- Coker crude distillation
- Vacuum distillation
- Crackers
- Hydrotreaters
- Visbreakers
- Crude oil
- Liquefied natural gas (LNG)

### Features and benefits

- No drifting flow measurement
- No periodic calibration required
- No maintenance
- No restriction in the pipe
- Reliable measurement by design— (IEC61508 certification)
- Flow measurement in extremely high-process temperature (600°C/1112°F) applications
- Flow measurement in extremely low-process temperature (-200°C/-328°F) applications
- Bi-directional measurement

## PanaFlow gives you confidence in your flow measurement

PanaFlow HT is a wetted ultrasonic flow meter that is SIL certified (IEC61508) by design to give you confidence in your flow measurement and to provide reliable flow meter operation for both safety and process control systems. It is the first SIL-rated ultrasonic flow meter on the market.

In addition to the peace of mind that SIL certification brings, PanaFlow HT also has all the advantages of ultrasonic flow measurement over other traditional technologies—no measurement drifting, no periodic calibration requirement, no restriction in the pipe, minimal pressure drop, no maintenance, and no moving parts.

## Fast and easy installation

Wetted systems typically provide higher accuracy than clamp-on systems, but installation can be complicated and difficult. If these systems are not installed with precision and close attention to detail, reliability and accuracy may not meet the product specifications. With the PanaFlow HT system, we do the assembly work at the factory. The necessary components are already installed, so all you need to do is bolt the end flanges into place.

## Transit-time flow measurement

In this measurement method, two transducers serve as both ultrasonic signal generators and receivers. They are in acoustic communication with each other, meaning that the second transducer can receive ultrasonic signals transmitted by the first transducer and vice versa.

In operation, each transducer functions as a transmitter, generating a certain number of acoustic pulses, and then as a receiver for an identical number of pulses. The time interval between transmission and reception of the ultrasonic signals is measured in both directions. When the liquid in the pipe is not flowing, the transit-time downstream equals the transit-time upstream. When the liquid is flowing, the transit-time downstream is less than the transit-time upstream.

The difference between the downstream and upstream transit times is proportional to the velocity of the flowing liquid, and its sign indicates the direction of flow.

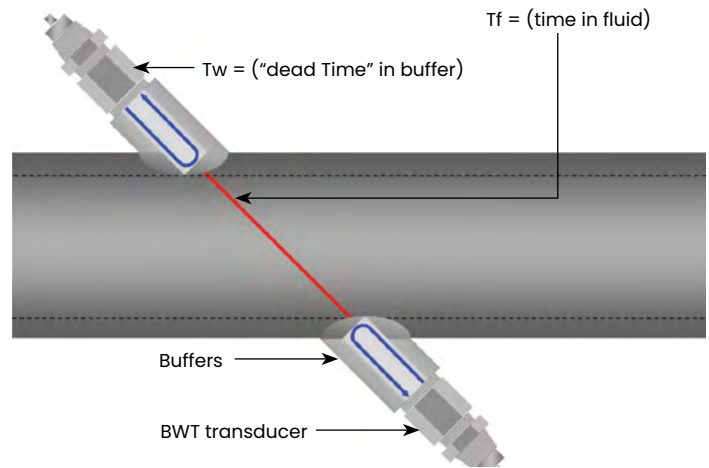

## Active temperature compensation

Ultrasonic flow meters use transit time to determine the liquid or gas flow in a pipeline. Measured transit time consists not only of the time the ultrasonic signal spends in a fluid, but also of a portion of "dead time," which is the time that the electrical signal is converted into an acoustical signal and the time the acoustic signal travels inside the buffer. To allow for the utmost accuracy, PanaFlow HT uses pulse echo technique to actively measure the dead time. By sending a pulse and measuring its reflection, the dead time is measured in real time rather than using a preset value. As a result of this GE invention, PanaFlow HT maintains its accuracy as process temperature conditions dynamically change.

## What is the PanaFlow HT system?

The PanaFlow HT system consists of the new XMT900 electronics, BWT transducer system, and meter body. The Panametrics XMT900 is our latest transmitter and it combines state-of-the-art flow measurement capability with rigorous IEC61508 software and hardware testing. The XMT910 leverages the XMT900 platform with a Foundation Fieldbus output for digital process control.

The Bundle Waveguide Transducer (BWT) system is field-proven to give accurate, drift-free, obstruction-less flow measurement in the most difficult liquid applications, while allowing access to the transducers at any time. The system consists of buffer assemblies and transducers.

The buffer assemblies use waveguide bundles to efficiently concentrate a greater amount of the transducer ultrasonic signal into the process. At the same time, the bundles act as buffers to protect the transducers from extreme temperatures to ensure their unlimited life. This innovative design greatly expands the range of possible applications. The ultrasonic signal transmitted through the buffer assemblies is powerful enough to penetrate all liquids, including high-viscosity, high-molecular weight liquids and liquids. The meter body comes in various configurations for pipe sizes up to 16 in (400 mm) standard and up to 36 in (900m) upon request. Also, the meter body is available in several materials and finishes.

## Safety terminology

**Overall safety** is defined as the freedom from unacceptable risk of physical injury or of damage to the health of people, either directly, or indirectly as a result of damage to property or to the environment.

**Functional safety** is the dependency on a system or piece of equipment under control to operate correctly and it is just one part of overall safety.

The goal of functional safety is to design, build, operate, and maintain systems in such a way as to prevent dangerous failures, or at the very least, to control them when they arise.

A risk-based approach must be used to determine the required performance of safety systems.



## IEC61508 standards

The common use of electronic control systems and their impact on equipment safety led to the development of the IEC 61508 family of standards, which focuses on the functional safety of electrical/electronic/programmable safety-related systems.

These international standards, introduced in 1998, led to the development of further standards (IEC61511 for Process Industry, as an example).

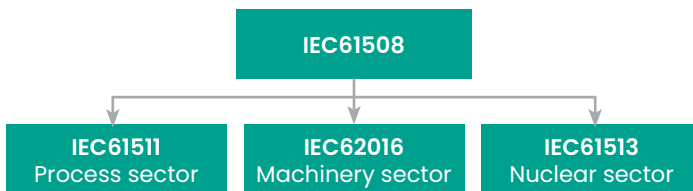

## Safety Instrumented System (SIS)

A Safety Instrumented System (or Safety Related System per IEC61508) is used to implement one or more Safety Instrumented Functions (SIFs).

SIF refers to a specific single set of actions and the corresponding equipment needed to identify a single hazard and act to return a system to a safe state. In a typical SIF, sensors identify a hazard, a logic solver determines the appropriate action, and final elements perform the actions.

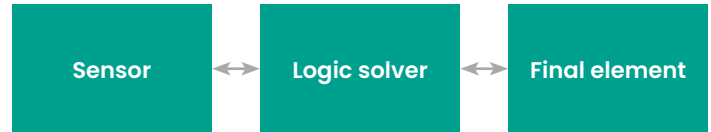

SIS automatically takes an industrial process to a safe state when specified conditions are violated. It permits a process to move forward in safe manner when specified conditions allow.

## How does PanaFlow HT fit with functional safety?

PanaFlow HT is a SIL2 ultrasonic flow meter (sensor) with the capability of a SIL3 system achievable in a redundant design configuration.

It is IEC61508 certified through a complete design validation from a third party organization. By achieving a third party certification, we have proven the required design rigor through the product safety lifecycle and functional safety management. This rigor makes PanaFlow HT the optimal ultrasonic flow meter for your safety or process control system.



# Overall operation and performance

## Fluid types

Liquids: acoustically conductive fluids, including most clean liquids, and many liquids with small amounts of entrained solids or gas bubbles

## Flow measurement

Patented Correlation Transit-Time™ mode

## Meter sizes

3 in to 16 in (80 mm to 600 mm) standard  
Optional: sizes up to 36 in (900 mm) are available upon request

## Accuracy

±0.5% of reading  
3 in to 4 in (80 mm to 100 mm) meter sizes, range: 7 to 40 ft/s (2.13 to 12.19 m/s)  
6 in to 36 in (150 mm to 900 mm) meter sizes, range: 3 to 40 ft/s (0.91 to 12.19 m/s)

±0.9% of reading  
3 in to 4 in (80 mm to 100 mm) meter sizes, range: 3 to 7 ft/s (0.91 to 2.13 m/s)

Final installation assumes a fully developed flow profile (typically 10 diameters upstream and 5 diameters downstream of straight pipe run) and single phase fluids. Applications with piping arrangements that induce swirl (e.g., two out-of-plane elbows) may require additional straight run or flow conditioning.

Larger meter sizes are available upon request.

## Repeatability

±0.25% of reading  
3 in to 4 in (80 mm to 100 mm) meter sizes, range: 7 to 40 ft/s (2.13 to 12.19 m/s)  
6 in to 36 in (150 mm to 900 mm) meter sizes, range: 3 to 40 ft/s (0.91 to 12.19 m/s)

±0.5% of reading  
3 in to 4 in (80 mm to 100 mm) meter sizes, range: 3 to 7 ft/s (0.91 to 2.13 m/s)

## Range (bidirectional)

0.1 to 40 ft/s (0.03 to 12.19 m/s)

## Rangeability (overall)

400:1

## SIL certification

IEC61508 certified  
SIL2 certification with single design system  
SIL3 certification with redundant design system

## Configurations

Z1H (single path)  
Z2H (dual path)  
R2H (redundant dual path staggered with two electronics)  
Optional: Alternative redundant path configurations (R3H or R4H) and designs are available upon request

## Meter body/transducer

### Meter body materials

Carbon steel (ASTM A106 Gr. B - ASTM A105)  
Stainless steel (ASTM A312 Gr 316/316L - A182 Gr. 316/316L)  
9Cr-1Mo (ASTM A335 Gr. P9 - ASTM A182 Gr. F9)

Optional: other materials available upon request

### Transducer system and material

Bundle Waveguide Technology™ (BWT) System transducer and holder  
316L stainless steel

Optional: Other alternative buffer materials are available upon request

### Transducer temperature ranges

Normal temperatures: -310°F to 600°F (-190°C to 315°C)  
Liquids, high temperatures: -310°F to 1112°F (-190°C to 600°C)

### Pressure range

Up to ANSI 600 class pressure rating based on material of construction

Optional: Up to ANSI 2500 class maximum allowable flange operating pressure at temperature in either ANSI or DIN designs

### Transducer classifications

Explosion-proof Class I, Division 1, Groups B, C, & D ATEX:  
Flameproof II 2 G Ex d IIC T6  
IECEx: Flameproof Ex d IIC T6



Bundle Waveguide Technology™ system, FTPA normal and high temperature buffers

## Electronics

### Enclosures

Epoxy coated, copper free, aluminum, weatherproof (IP67)

### Electronics certifications

Explosion-proof Class I, Division 1, Groups B, C, and D

ATEX - Flameproof II 2 G Ex d IIC T6 Gb

IECEX - Flameproof Ex d IIC T6 Gb

ROHS compliance

(Category 9 exemption)

CE

WEEE compliance

### Electronics mounting

Local mounting (on meter body)

Remote mounting (up to 100 ft/30.4 m)

### Channels

One or two (two channels for two-path averaging)

### Display languages

English

### Keypad

Built-in magnetic, six-button keypad, for full functionality operation

### Inputs/outputs

#### XMT900

Option A: One analog/SIL output with HART, two digital\* outputs, service/Modbus (RS485) output

Option B: One analog/SIL output with HART, one additional analog (4-20mA) output, two digital\* outputs, service/Modbus (RS485) output

#### XMT910

Option F: One Foundation Fieldbus output, and one service/Modbus (RS485) output (not SIL certified)

\*Digital outputs are programmable as either pulse, frequency, alarm, or control outputs

Analog outputs are NAMUR NE43 compliant

### Power supplies

Standard: 100-240 VAC (50/60 Hz)

Optional: 12-28 VDC

### Wiring connection

¾" NPT

M20

### Operating temperature

-40°F to 140°F (-40°C to +60°C)

### Storage temperature

-40°F to 158°F (-40°C to 70°C)

### Data logging

XMT900/XMT910 meter logging Vitality software logging



Panametrics XMT900/XMT910 transmitter

## Transducer cables

**Integrated cables:** armored cable with certified cable glands or potted mineral insulated cable

**Remote cables:** armored cable with certified cable glands or no cable glands (no cable glands requires conduit or other means to meet local area code)

# Ordering information

A	B	C	D	E	F	G	H	I	J	K	L	M	N	O	Z
PF9-Z1H															<b>Model</b>
PF9-Z2H															Single path, single traverse design
PF9-R2H															Dual path, single traverse design
															Redundant dual path, staggered, single traverse, two electronics design
															<b>Meter body size</b>
			03												3in (80mm) meter body
			04												4in (100mm) meter body
			06												6in (150mm) meter body
			08												8in (200mm) meter body
			10												10in (250mm) meter body
			12												12in (300mm) meter body
			14												14in (350mm) meter body
			16												16in (400mm) meter body
															<b>Meter body schedule and flange rating</b>
		A													ANSI 150# RF (WN) process flange with standard schedule
		B													ANSI 300# RF (WN) process flange with XS schedule
		C													ANSI 600# RF (WN) process flange with XS schedule
															<b>Meter body material</b>
			CS												Carbon steel meter body (ASTM A106 Gr. B - ASTM A105)
			S6												316 stainless steel meter body (ASTM A312 Gr 316 - A182 Gr. 316)
			9C												9Cr-1Mo meter body (ASTM A335 Gr. P9 - ASTM A182 Gr. F9)
															<b>Design criteria</b>
				A											ASME B31.3 and designed to NACE MR0103
				P											PED compliant and designed to NACE MR0103
				C											ASME B31.3, CRN registered, and designed to NACE MR0103
															<b>Paint</b>
					A										No paint (recommended for stainless steel meters only)
					B										High temperature primer (maximum temperature 750°F (400°C))
					C										Standard gray epoxy paint (maximum temperature 450°F (230°C))
															<b>NDE</b>
						1									NDE testing: MPI, X-ray, and hydrostatic
						2									NDE testing: MPI, X-ray, hydrostatic, and positive material inspection
						3									NDE testing: LPI, X-ray, and hydrostatic
						4									NDE testing: LPI, X-ray, hydrostatic, and positive material inspection
															<b>Electronics mounting</b>
							L								Local mounting of electronics
							R25								Remote mounting of electronics with 25 feet of cable
							R50								Remote mounting of electronics with 50 feet of cable
							R100								Remote mounting of electronics with 100 feet of cable
															<b>Enclosure</b>
								1							Epoxy coated aluminum enclosure (IP67)
															<b>Connections</b>
									1						3/4" NPT
									2						M20
															<b>Power</b>
										1					100-240 VAC
										2					12-28 VDC
															<b>Display option</b>
											1				Local display
															<b>Communication</b>
												A			One SIL rated analog/HART output, two digital outputs (XMT900)
												B			One SIL rated analog/HART output, one analog output, two digital outputs (XMT900)
												F			One Foundation Fieldbus output (not SIL certified -- XMT910)
															<b>Transducers/buffers</b>
													1		0.5 MHz high temperature BWT/FTPFA transducer system (-200 to 600 deg C)
													3		0.5 MHz normal temperature BWT/FTPFA transducer system (-200 to 315 deg C)
															<b>System rating</b>
														A	Explosion-proof enclosure, Class I, Div 1, Group B, C, & D (CSA / FM)
														E	Flameproof enclosure, II 2 G EEx d II C T6 Gb (ATEX)
														F	Flameproof stainless steel enclosure, II 2 G EEx d II C T6 Gb (ATEX)
														I	Flameproof enclosure, Ex d II C T6 Gb (IECEX)
															<b>Specials</b>
														0	None
														S	Special

## Z1H design

Configuration	Nominal pipe size (in)	FTF length in (mm)	Width in (mm)	Height (local) in (mm)	Height (remote) in (mm)	Mass lbs (kgs)
Z1H	3	30 (762)	40 (1016)	27 (686)	20 (508)	143 (65)
	4	30 (762)	41 (1042)	28 (712)	22 (559)	191 (87)
	6	36 (915)	43 (1093)	31 (788)	25 (635)	250 (113)
	8	36 (915)	45 (1143)	33 (839)	27 (686)	420 (191)
	10	42 (1067)	47 (1194)	36 (915)	30 (762)	615 (279)
	12	42 (1067)	49 (1245)	38 (966)	32 (813)	649 (294)
	14	48 (1220)	51 (1296)	40 (1016)	33 (839)	849 (385)
	16	54 (1372)	53 (1347)	42 (1067)	36 (915)	1133 (514)

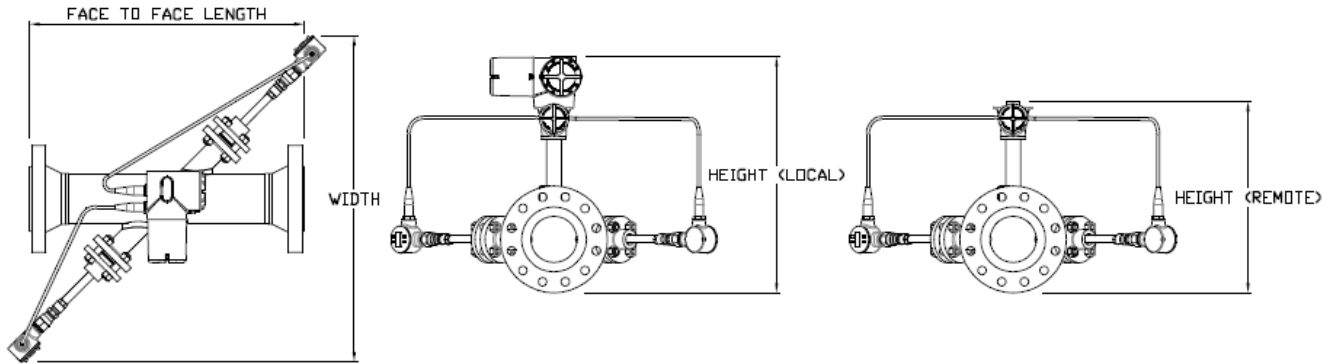

## Z2H design

Configuration	Nominal pipe size (in)	FTF length in (mm)	Width in (mm)	Height (local) in (mm)	Height (remote) in (mm)	Mass lbs (kgs)
Z2H	6	42 (1067)	41 (1042)	35 (889)	29 (737)	352 (160)
	8	42 (1067)	43 (1093)	36 (915)	30 (762)	484 (220)
	10	48 (1220)	45 (1143)	38 (966)	32 (813)	676 (307)
	12	48 (1220)	47 (1194)	39 (991)	33 (839)	802 (364)
	14	54 (1372)	48 (1220)	40 (1016)	34 (864)	911 (413)
	16	54 (1372)	49 (1245)	42 (1067)	36 (915)	1194 (542)

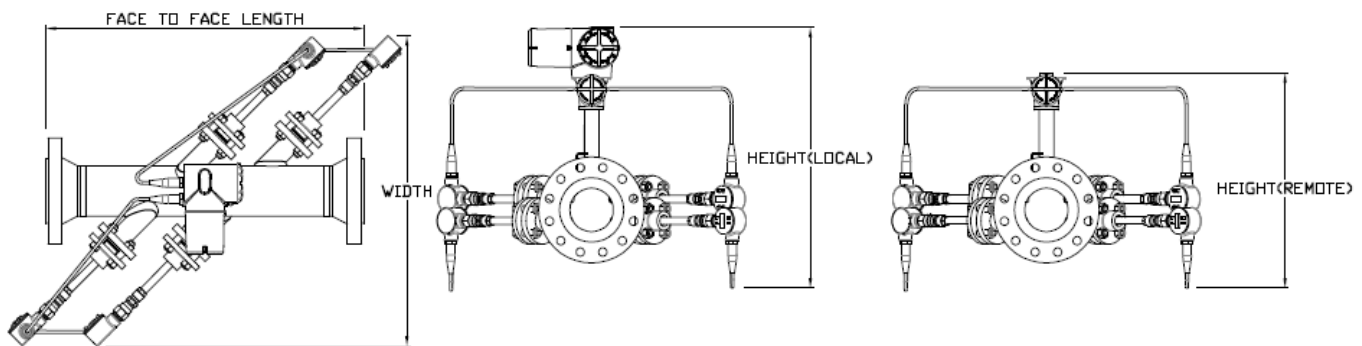

## R2H design

Configuration	Nominal pipe size (in)	FTF length in (mm)	Width in (mm)	Height (local) in (mm)	Height (remote) in (mm)	Mass lbs (kgs)
R2H	3	48 (1220)	40 (1016)	27 (686)	20 (508)	244 (111)
	4	54 (1372)	41 (1042)	28 (712)	22 (559)	301 (137)
	6	66 (1677)	43 (1093)	31 (788)	25 (635)	449 (204)

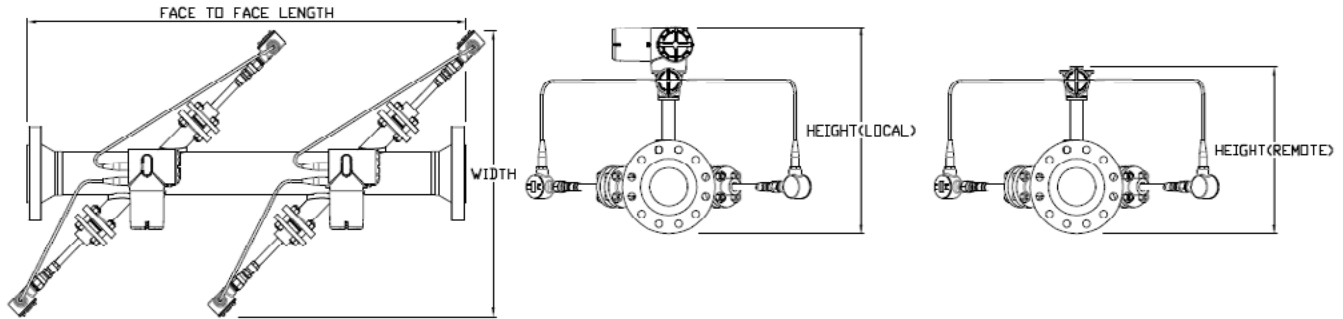

R3H or R4H (redundant three or four path) designs are available upon request.