

# Masoneilan™ 41005 Series

Complete Line of Cage-Guided,  
Globe Valves with **Lo-dB™**,  
Anti-Cavitation and High  
Pressure API 6A Capabilities



# Table of Contents

## **41005 Series High Pressure Valves**

Numbering System .....	3
Ratings / Connections .....	4
Seal Type vs Temperature Range/Seat Leakage .....	5
Seal Type vs Trim Type .....	5-16
Body S/A Construction .....	17-18
Materials of Construction .....	19-22
Trim Types .....	23
Seal Ring Construction .....	24-25
Materials of Construction .....	26-29
Dimensions (inches) .....	30-32
Dimensions (mm) .....	33-35
Weights .....	36-38
Options .....	38

## **41005 API-6A Series High Pressure Valves ..... 40**

Features .....	40
Numbering System .....	41
Temperature Ratings .....	41
Material Class/Material of Construction .....	41
Ratings/End Connections .....	42
$C_V$ and $F_L$ Versus Travel .....	42-43
Body Sub Assembly Construction .....	44-45
Materials of Construction .....	46-47
Dimensions .....	48
Weights/Center of Gravity .....	49
Weights and Dimensions 87/88 Actuator .....	50-53
Common Parts .....	53
Dimensions 51/52/53 Actuator .....	54-56
Weights 51/52/53 Actuator .....	57-58

# Numbering System

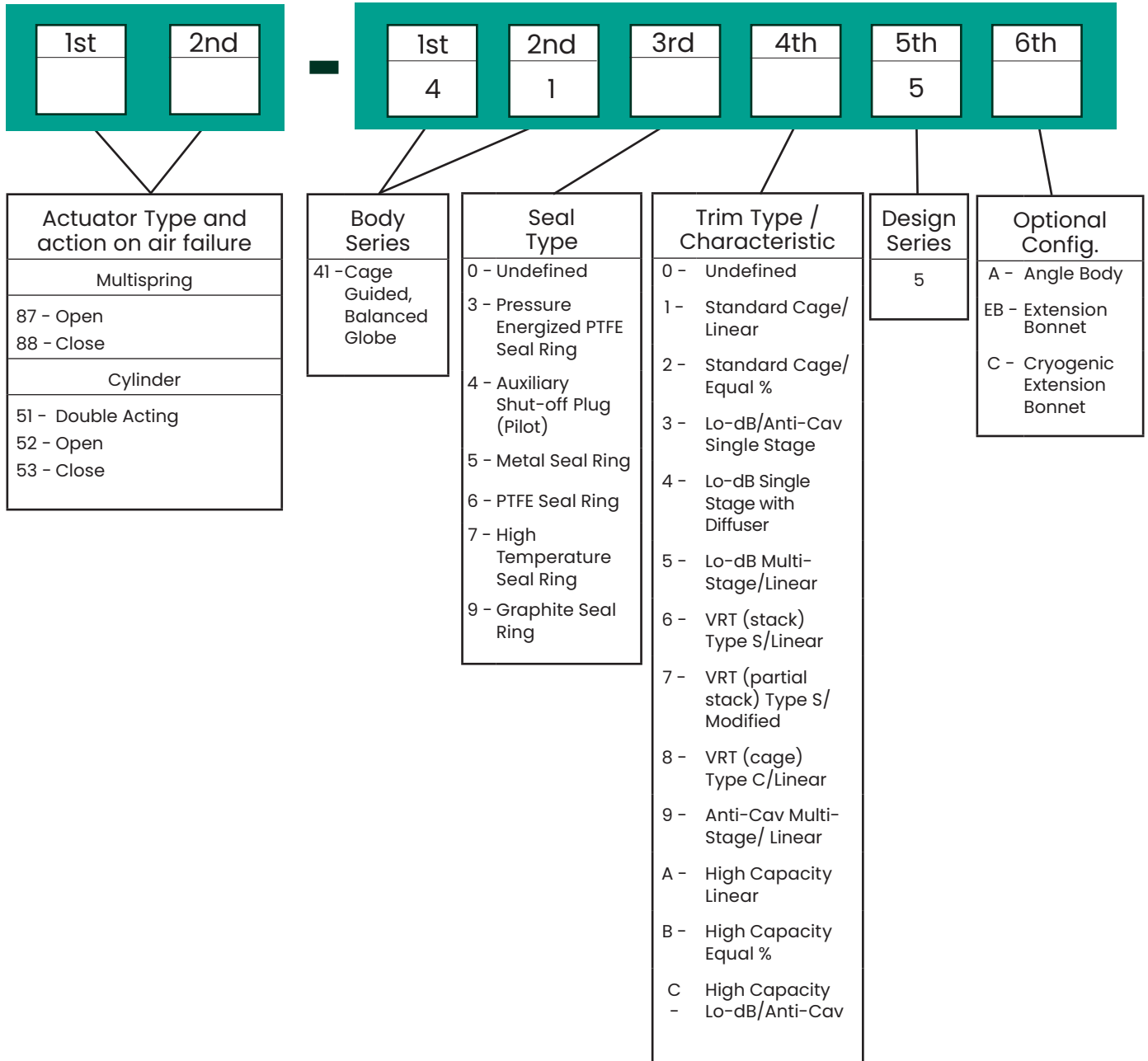

Engineered trim options are also available for high temperature and high pressure drop applications. Please consult factory for details.

# Ratings / Connections

 Threaded  
  Socket Weld  
  Butt Weld  
  RF & RTJ

Valve Size		ASME Class 150 to 1500 and equivalent PN				ASME Class 2500 and equivalent PN		
inch	mm							
2	50	■	●	□	○	■	●	□
3	80	■		□		■		□
4	100	■		□		■		□
6 <sup>(1)</sup>	150	■		□		■		□
8 <sup>(1)</sup>	200	■		□		■		□
10 <sup>(1)</sup>	250	■		□		■		□
12 <sup>(1)</sup>	300	■		□		■		□
14 <sup>(3)</sup>	350	■		□				
16 <sup>(2)</sup>	400	■		□		■		
18 <sup>(1)</sup>	450	■		□				
20 <sup>(4)</sup>	500	■		□				
24 <sup>(5)</sup>	600	■		□				
30 <sup>(8)</sup>	762	■		□				
3x2	80x50	■		□		■		□
4x2	100x50	■		□		■		□
4x3	100x80	■		□				
6x3	150x80	■		□				
6x4	150x100	■		□				
8x4	200x100	■		□				
8x6	200x150	■		□				
10x6	250x150	■		□				
10x8	250x200	■		□				
12x8	300x200	■		□				
16x12	400x300	■		□				
30x32 <sup>(9)</sup>	762x813	■		□				

- 6" through 12" + 18" High Capacity designs available in ASME Class 150 to 600 only. 20" and 24" High Capacity designs available in ASME Class 150 to 300 only.
- 16" ASME Class 2500 available in Butt Weld end connections only. 16" High Capacity design is available in ASME Class 600 only.
- 14" ASME Class limited to 1500. There is no 14" size in High Capacity design.
- 20" available in ASME Classes 150 to 900 only.
- 24" available in ASME Classes 150 to 600 only.
- Angle body versions are available in 2" to 8" in ASME Classes 150 to 1500.
- Consult Baker Hughes for DIN and special end connections and unlisted constructions.
- CL 150-600 Flanged only.
- CL 150-300 Flanged only.

# Seal Type vs Temperature Range/Seat Leakage

Valve Model	Seal Type	Valve Size		Temperature Range <sup>(1)</sup>				Seat Leakage per IEC 534-4 and ASME / FCI 70.2 Class
		inches	mm	Minimum		Maximum		
41305	Pressure Energized PTFE Seal Ring	2 - 30	50 - 600	-148°F	-100°C	+450°F	+232°C	IV (standard) V (optional)
		2 - 24 <sup>(2)</sup>	50 - 300			+575°F	+302°C	
41405	Auxiliary Pilot Plug with Metal Seal Ring	2	50	-320°F	-196°C	+1099°F	+593°C	IV (standard) V (optional)
		3 - 4	80 - 100			+800°F	+427°C	
		6 - 18	150 - 450			+1099°F	+593°C	
41505	Metal Seal Ring	2	50	-320°F	-196°C	+1099°F	+593°C	II
		3 - 4	80 - 100			+800°F	+427°C	II
		6 - 18	150 - 450			+1099°F	+593°C	III
		20 & 24	500 & 600			-51°F	-46°C	+650°F
41605	PTFE Seal Ring	2 - 24	50 - 600	-20°F	-29°C	+300°F	+149°C	IV
41705	High Temperature Seal Ring	4	100	-20°F	-29°C	+800°F	+427°C	V
		6 - 12	150 - 300			FTO +850°F	+454°C	
41905	Graphite Seal Ring	2	50	-320°F	-196°C	+849°F	+454°C	III
		3 - 4	80 - 100			+800°F	+427°C	
		6 - 18	150 - 450			+850°F	+454°C	IV
		20 & 24	500 & 600			-51°F	-46°C	

1. See Materials of Construction Tables for other temperature limitations.
2. Pressure Energized PTFE Seal w/ backup rings for 2-24" up to 575°F (302°C)

# Seal Type vs Trim Type

Model No.	413X5	414X5 <sup>(1 &amp; 4)</sup>	415X5	416X5	417X5 <sup>(7)</sup>	419X5
Trim Type	Seal Type					
	Pressure Energized PTFE Seal Ring	Auxiliary Pilot Plug with Metal Seal Ring	Metal Seal Ring	PTFE Seal Ring	High Temperature Seal Ring	Graphite Seal Ring
Standard Trim 41X15/41X25	41315/41325 FTO or FTC <sup>(2)</sup>	41415/41425 FTC	41515/41525 FTO or FTC	41615/41625 FTO or FTC	41715/41725 FTO	41915/41925 FTO or FTC
Lo-dB Single Stage 41X35	41335 FTO	41435 FTC	41535 FTO	41635 FTO	41735 FTO	41935 FTO
Anti-Cavitation, Single Stage 41X35	41335 FTC	41435 FTC	41535 FTC	41635 FTC	-	41935 FTC
Lo-dB Single Stage with Internal Diffuser 41X45 <sup>(3)</sup>	-	41445 FTC	-	-	-	-
Lo-dB Multi-Stage 41X55	41355 FTO	-	41555 FTO	41655 FTO	41755 FTO	41955 FTO
High Pressure Anti-Cavitation VRT	41365 <sup>(5)</sup> 41375 <sup>(6)</sup>	-	-	-	-	-
Anti-Cavitation, Multi-Stage 41X95	41395 FTC	-	41595 FTC	41695 FTC	-	41995 FTC

1. Flow direction for Pilot Plug Seal configuration is always FTC.
2. Seal ring must be installed in correct orientation relative to high pressure direction.
3. Flow direction with Internal Diffuser is always FTC.
4. 41405 is not available in 20" or 24" sizes.
5. 41365 available in 8", 10" and 12" sizes.
6. 41375 available in 3" to 10".
7. 41705 available in 4" to 12". 4" size is limited to 800°F for FTO only.

# C<sub>v</sub> and F<sub>L</sub> Versus Travel

Standard Trim

Models: 41315, 41415<sup>(1)</sup>, 41515, 41615, 41715 and 41915

Flow Characteristic: LINEAR

							Percent of Travel											
							10	20	30	40	50	60	70	80	90	100		
							F <sub>L</sub>											
Valve Size		ASME CLASS and Equivalent PN	Orifice Diameter		Travel		Rated C <sub>v</sub>											
inches	mm		in.	mm	in.	mm												
2	50	900-1500-2500	1.84	46.7	0.8	20.3	1.4	2.7	4.2	6	8	10	12.5	14	15.5	16		
							2	4.9	8.3	13	19	25	30	35	38	40		
2	50	150-600	2.5	63.5	1.5	38.1	2.7	5.1	7.9	11	15	19	23	26	29	30		
3x2 <sup>(2)</sup>	80x50	150-1500					4	9	15	24	35	47	57	65	71	75		
4x2	100x50	2500																
3	80	2500	3.5	88.9	2	50.8	5	10	16	22	30	38	46	52	58	60		
4x3	80	150-1500					8	19	31	50	73	96	118	135	147	155		
6x3	100x80	150x80															2500	
4	100	2500	4.38	111	2	50.8	9	16	25	35	48	60	72	83	91	95		
4	100	150-1500					12	29	48	77	113	149	182	209	228	240		
6x4	150x100	150-1500															2500	
6	150	2500	5.12	130	0.8 <sup>(3)</sup>	20.3 <sup>(3)</sup>	7	15	28	41	58	74	94	117	144	165		
6	150	150-1500					2	50.8	20	52	92	148	204	260	308	348	376	400
8x6	200x150	150-1500																
8	200	2500	6.5	165	1.5	38.1	17	37	71	104	145	187	237	295	361	415		
8	200	150-1500					2.5	36.5	32	83	147	237	326	416	493	557	602	640
10x8	250x200	150-1500																
10	250	2500	8	203	1.5	38.1	20	46	87	128	179	230	291	362	444	510		
10	250	150-1500					3	76.2	50	130	230	370	510	650	770	870	940	1000
12x8	300x200	150-1500																
12	300	2500	9.75	248	2	50.8	31	69	131	193	270	347	439	547	670	770		
12	300	150-1500					3.75	95.3	70	182	322	518	714	910	1078	1218	1316	1400
16x12	400x300	150-1500																
14	350	150-1500	11.55	293	2.5	63.5	15	97	195	304	413	528	643	757	872	980		
							4	102	57	216	391	573	756	935	1106	1262	1399	1520
							5	127	105	330	573	822	1064	1288	1486	1654	1792	1900
16	400	150-1500	13	330	2.5	63.5	51	128	211	320	448	576	730	922	1114	1280		
							4	102	104	268	464	744	1024	1304	1544	1720	1880	2000
							5	127	130	335	580	930	1280	1630	1930	2150	2350	2500
18	450	150-1500	14.5	368	3.5	88.9	84	217	376	603	829	1056	1251	1393	1523	1620		
							5	127	120	310	536	859	1183	1506	1783	1987	2171	2310
							7	178	168	434	752	1205	1659	2112	2501	2786	3046	3110
20	500	150-900	19	483	4	102	79	422	790	1158	1517	1860	2182	2481	2753	3000		
							6	152	244	792	1343	1866	2342	2762	3124	3431	3688	3900
							9	229	524	1356	2103	2724	3219	3604	3907	4147	4342	4500
24	600	150-600	23	584	4	102	114	608	1138	1668	2187	2688	3161	3604	4011	4300		
							6	152	345	1115	1892	2635	3321	3933	4468	4928	5320	5600
							9	229	703	1832	2871	3765	4499	5094	5569	5952	6265	6500
							11	279	964	2327	3511	4460	5191	5749	6180	6519	6793	7000
30, 32x30 FTO	762	150-600 <sup>(4)</sup>	29	736	15	381	1185	2631	3946	5084	6129	7181	8143	8954	9650	10500		
30, 32x30 FTC							1184	2621	3921	5034	6043	7048	7955	8712	9290	9750		

1. Model 41415 is not available in 20", 24", and 30" sizes.

2. Ex. 3x2 size = valve with 3" body with standard 2" trim.

3. Travel of 1.5" (38.1 mm) for 41405.

4. Size 32x30 is available only for Class 150-300.

# C<sub>V</sub> and F<sub>L</sub> Versus Travel

Balanced Trim

Models: 413A5, 415A5, 416A5 and 419A5 Series

Flow Characteristic: LINEAR, High Capacity

Percent of Travel								10	20	30	40	50	60	70	80	90	100	
F <sub>L</sub>								0.94	0.94	0.93	0.93	0.92	0.92	0.91	0.91	0.90	0.90	
Valve Size		ASME CLASS and Equivalent PN	Orifice Diameter		Travel		Flow Dir.	Rated C <sub>V</sub>										
in.	mm		in.	mm	in.	mm												
6	150	150-600	6.5	165	2.5	63.5	FTC	67	123	185	246	303	353	396	430	454	469	
							FTO	71	132	197	262	323	377	423	458	485	501	
8	200	150-600	8	203	3.5	88.9	FTC	109	202	303	403	497	580	649	705	745	770	
							FTO	125	231	346	461	568	663	742	805	851	880	
10	250	150-600	9.57	243	3.5	88.9	FTC	153	283	424	564	695	812	909	986	1042	1078	
							FTO	174	322	482	642	791	923	1034	1122	1186	1226	
12	300	150-600	10.75	273	5.5	140	FTC	145	290	435	580	725	870	1015	1160	1305	1450	
							FTO	151	303	454	605	757	908	1059	1210	1362	1513	
16	400	600	14.4	366	6	152	FTC	356	660	989	1316	1622	1893	2121	2301	2432	2515	
					6.15	156	FTO	397	735	1101	1465	1806	2107	2361	2562	2707	2800	
18	450	150-600	16.89	429	7.5	191	FTC	296	913	1419	1954	2445	2878	3201	3471	3610	3705	
							FTO	299	789	1322	1870	2293	2600	2939	3081	3374	3430	
20	508	150-300	23	584	11	279	FTC	540	1082	1622	2163	2704	3245	3786	4326	4867	5408	
							FTO	571	1142	1714	2285	2856	3425	4000	4570	5140	5712	
24	609	150-300	27	686	12	305	FTC	1205	2233	3345	4450	5483	6400	7170	7780	8220	8500	
							FTO	1177	2180	3266	4345	5354	6248	7000	7595	8030	8300	

# C<sub>v</sub> and F<sub>L</sub> Versus Travel

Standard Trim

Models: 41325, 41425<sup>1</sup>, 41525, 41625, 41725 and 41925

Flow Characteristic: EQUAL PERCENTAGE

Percent of Travel							10	20	30	40	50	60	70	80	90	100	
F <sub>L</sub>							0.94	0.94	0.94	0.94	0.94	0.94	0.93	0.92	0.92	0.92	0.90
Valve Size		ASME CLASS and Equivalent PN	Orifice Diameter		Travel		Rated C <sub>v</sub>										
in.	mm		in.	mm	in.	mm											
2	50	900-1500-2500	1.84	46.7	0.8	20.3	0.2	0.4	0.8	1.3	2.1	3.8	6.7	10	12	14	
							0.5	1.1	2	3.2	5.2	9.5	17	25	31	35	
2 3x2 <sup>(2)</sup> 4x2	50 80x50 100x50	150-600	2.5	63.5	1.5	38.1	0.3	0.8	1.5	2.3	4	7	12	18	23	26	
							0.8	2	4	6	10	18	31	46	58	65	
3	80	2500															
3 4x3 6x3	80 100x80 150x80	150-1500	3.5	88.9	2	50.8	0.7	1.7	3	5	8	15	27	39	50	56	
							1.8	4	8	13	21	38	67	100	124	140	
4	100	2500															
4 6x4 8x4	100 150x100 200x100	150-1500	4.38	111	2	50.8	1.2	3	5	8	13	24	43	64	81	90	
							3	7	13	20	33	61	107	160	200	225	
6	150	2500															
6 8x6 10x6	150 200x150 250x150	150-1500	5.12	130	2	50.8	4	8	15	24	35	54	80	108	130	144	
							9	21	39	60	87	135	200	269	326	360	
8	200	2500															
8 10x8 12x8	200 250x200 300x200	150-1500	6.5	165	2.5	63.5	6	14	25	39	56	86	128	172	208	230	
							14	34	62	97	140	215	320	430	521	575	
10	250	2500															
10	250	150-1500	8	203	3	76.2	9	21	39	60	87	135	200	269	326	360	
12	300	2500					23	53	97	151	219	337	500	672	815	900	
12 16x12	300 400x300	150-1500	9.75	248	3.75	95.3	13	30	54	84	122	187	278	374	453	500	
							32	75	136	212	306	471	700	941	1142	1260	
14	350	150-1500	11.5	292	5	127	17	28	43	62	93	139	196	286	469	680	
							38	116	202	321	511	789	1099	1357	1553	1700	
16	400	150-1500	13	330	5	127	22	53	97	151	219	337	500	672	815	900	
							56	133	243	378	547	842	1251	1681	2038	2250	
18	450	150-1500	14.5	368	3.5	127	29	69	125	195	282	434	645	867	1051	1160	
					7	178	72	171	313	487	705	1085	1612	2167	2627	2784	
20	500	150-900	19	483	4	102	12	82	162	257	386	589	854	1119	1375	1620	
					9	229	75	218	404	656	981	1426	2109	2944	3596	4050	
24	600	150-600	23	584	6	152	39	139	249	386	574	852	1256	1694	2118	2520	
					11	279	133	344	572	1005	1608	2406	3553	4814	5692	6300	
30, 32x30 FTO	762	150-600 <sup>(3)</sup>	29	736	15	381						2729	3466	4363	6334	8500	
30, 32x30 FTC												2719	3430	4300	6136	8000	

1. Model 41425 is not available in 20", 24", and 30" sizes.
2. Ex. 3x2 size = valve with 3" body with standard 2" trim.
3. Size 32x30 is available only for Class 150-300.



# C<sub>V</sub> and F<sub>L</sub> Versus Travel

Balanced Trim

Models: 413B5, 415B5, 416B5 and 419B5 Series

Flow Characteristic: EQUAL PERCENT, High Capacity

Percent of Travel								10	20	30	40	50	60	70	80	90	100	
F <sub>L</sub>								0.94	0.94	0.94	0.94	0.94	0.94	0.93	0.92	0.92	0.92	0.90
Valve Size		ASME CLASS and Equivalent PN	Orifice Diameter		Travel		Flow Dir.	Rated C <sub>V</sub>										
in.	mm		in.	mm	in.	mm												
6	150	150-600	6.5	165	2.5	63.5	FTC	20	32	53	85	131	191	261	331	394	437	
							FTO	21	34	56	90	139	201	275	349	415	461	
8	200	150-600	8	203	3.5	88.9	FTC	51	79	124	189	277	383	494	595	670	707	
							FTO	63	97	152	232	340	470	607	731	822	869	
10	250	150-600	9.57	243	4	102	FTC	48	78	127	204	315	458	624	793	942	1047	
							FTO	55	90	148	237	365	531	724	920	1093	1215	
12	300	150-600	10.75	273	5.5	140	FTC	143	286	429	572	715	858	1001	1144	1287	1430	
							FTO	108	166	260	399	584	805	1040	1253	1410	1490	
16	400	600	14.4	366	7	178	FTC	178	275	431	660	956	1333	1721	2074	2334	2466	
							FTO	190	293	458	701	1027	1418	1831	2206	2483	2623	
18	450	150-600	16.89	429	7.5	191	FTC	66	188	348	558	969	1509	2158	2621	2801	2976	
							FTO	70	195	360	599	997	1591	2339	2957	3431	3661	
20	508	150-300	23	584	11	279	FTC	117	273	507	780	1131	1755	2600	3497	4238	4680	
							FTO	128	300	556	856	1241	1926	2853	3837	4650	5135	
24	609	150-300	27	686	12	305	FTC	310	513	862	1414	2205	3215	4353	5418	6250	6700	
							FTO	323	536	900	1477	2303	3360	4538	5660	6530	7000	

# C<sub>V</sub> and F<sub>L</sub> Versus Travel

Single Stage Lo-dB/Anti-Cavitation

Models: 41335, 41435<sup>(1)</sup>, 41445<sup>(1)</sup>, 41535, 41635, 41735, and 41935  
(with internal diffuser)

Flow Characteristic: LINEAR

Percent of Travel							10	20	30	40	50	60	70	80	90	100			
F <sub>L</sub>							0.94	0.94	0.94	0.94	0.94	0.94	0.94	0.94	0.94	0.94	0.94		
Valve Size		ASME CLASS and equivalent PN	Orifice Diameter		Travel		Rated C <sub>V</sub>												
in.	mm		in.	mm	in.	mm	1	2	3	4	5	6	7	8	9	10			
2	50	900-2500	1.84	46.7	0.8	20.3	1	2	3	4	5	6	7	8	9	10			
							1.3	2.6	3.9	5.2	6.5	7.8	9.1	10.4	11.7	13			
							1.7	3.4	5.1	6.8	8.5	10.2	11.9	13.6	15.3	17			
							2.3	4.6	6.9	9.2	11.5	13.8	16.1	18.4	20.7	23			
							3	6	9	12	15	18	21	24	27	30			
2	50	150-600	2.5	63.5	1.5	38.1	2.5	5	7.5	10	12.5	15	17.5	20	22.5	25			
							3	6	10	13	16	19	22	26	29	32			
							4	9	13	17	22	26	30	34	39	43			
3x2	80x50	150-1500	2.5	63.5	1.5	38.1	6	12	17	23	29	35	41	46	52	58			
4x2	100x50						7	14	22	29	36	43	50	58	65	72			
3	80	2500	3.5	88.9	2	50.8	4	8	12	16	20	24	28	32	36	40			
3	80	150-1500					5	11	16	22	27	32	38	43	49	54			
							7	14	22	29	36	43	50	58	65	72			
							10	19	29	38	48	57	67	76	86	95			
4	100	2500					13	25	38	50	63	75	88	100	113	125			
4	100	150-1500	4.38	111	2	50.8	7	13	20	26	33	39	46	52	59	65			
							9	17	26	34	43	51	60	68	77	85			
							11	22	33	44	55	66	77	88	99	110			
							15	30	45	60	75	90	105	120	135	150			
6	150	2500	20	39	59	78	98	117	137	156	176	195							
6	150	150-1500	5.12	130	2.5	63.5	10	20	30	40	50	60	70	80	90	100			
							13	26	39	52	65	78	91	104	117	130			
							18	35	53	70	88	105	123	140	158	175			
							23	46	69	92	115	138	161	184	207	230			
							30	60	90	120	150	180	210	240	270	300			
8	200	150-1500	6.5	165	2.5	63.5	16	32	48	64	80	96	112	128	144	160			
							21	42	63	84	105	126	147	168	189	210			
							27	54	81	108	135	162	189	216	243	270			
					10	250	2500	3	76.2	36	72	108	144	180	216	252	288	324	360
										50	100	150	200	250	300	350	400	450	500
10	250	150-1500	8	203	2.5	63.5	20	40	60	80	100	120	140	160	180	200			
							26	52	78	104	130	156	182	208	234	260			
					3.5	88.9	36	72	108	144	180	216	252	288	324	360			
							50	100	150	200	250	300	350	400	450	500			
12	300	2500	9.75	248	2.5	63.5	45	90	135	180	225	270	315	360	405	450			
							60	120	180	240	300	360	420	480	540	600			
							4	102	81	162	243	324	405	486	567	648	729	810	
16	400	2500	5	127	110	220	330	440	550	660	770	880	990	1100					
14	350	150-1500	11.5	292	2.5	63.5	38	113	170	244	318	389	442	510	592	640			
							4	102	73	178	281	383	482	578	671	760	848	920	
							4	102	89	222	352	478	599	713	821	921	1014	1100	
							5.5	140	140	346	523	690	847	1007	1137	1254	1357	1450	

Table continued next page.

## C<sub>v</sub> and F<sub>L</sub> Versus Travel (Cont.)

Single Stage Lo-dB/Anti-Cavitation

Models: 41335, 41435<sup>(1)</sup>, 41445<sup>(1)</sup>, 41535, 41635, 41735, and 41935  
(with internal diffuser)

Flow Characteristic: LINEAR

Percent of Travel							10	20	30	40	50	60	70	80	90	100	
F <sub>L</sub>							0.94	0.94	0.94	0.94	0.94	0.94	0.94	0.94	0.94	0.94	0.94
Valve Size		ASME CLASS and equivalent PN	Orifice Diameter		Travel		Rated C <sub>v</sub>										
in.	mm		in.	mm	in.	mm											
16	400	150-1500	13	330	2.5	63.5	73	146	219	292	365	438	511	584	657	730	
					4	102	99	198	297	396	495	594	693	792	891	990	
							130	260	390	520	650	780	910	1040	1170	1300	
6	152	180	360	540	720	900	1080	1260	1440	1620	1800						
18	450	150-1500	14.5	368	3.5	88.9	107	214	321	428	535	642	749	856	963	1070	
					5	127	139	278	417	556	695	834	973	1112	1251	1390	
							185	370	555	740	925	1110	1295	1480	1665	1850	
7	178	243	486	729	972	1215	1458	1701	1944	2187	2430						
20	500	150-900	19	483	4	102	190	380	570	760	950	1140	1330	1520	1710	1900	
					6	152	280	560	840	1120	1400	1680	1960	2240	2520	2800	
					9	229	350	700	1050	1400	1750	2100	2450	2800	3150	3500	
24	600	150-600	23	584	4	102	270	540	810	1080	1350	1620	1890	2160	2430	2700	
					6	152	350	700	1050	1400	1750	2100	2450	2800	3150	3500	
					9	229	480	960	1440	1920	2400	2880	3360	3840	4320	4800	
					11	279	540	1080	1620	2160	2700	3240	3780	4320	4860	5400	
					15	381	660	1320	1980	2640	3300	3960	4620	5280	5940	6600	
30, 32x30	762	150-600 <sup>(3)</sup>	29	736	15	381	1270	2592	3784	4783	5604	6273	6816	7263	7633	8000	

1. Models 41435 and 41445 are not available in 20", 24", and 30" sizes.

2. Ex. 3x2 size = valve with 3" body with standard 2" trim.

3. Size 32x30 is available only for Class 150-300.

# C<sub>V</sub> and F<sub>L</sub> Versus Travel

Balanced Single Stage Anti-Cav / Lo-dB Trim  
Models: 413C5, 415C5, 416C5 and 419C5 Series

Flow Characteristic: LINEAR High Capacity

Percent of Travel							10	20	30	40	50	60	70	80	90	100	
F <sub>L</sub>							0.94	0.94	0.94	0.94	0.94	0.94	0.94	0.94	0.94	0.94	0.94
Valve Size		ASME CLASS	Orifice Diameter		Travel		Rated C <sub>V</sub>										
in.	mm		in.	mm	in.	mm											
6 6x8x6	150	150-600	6.5	165	2.5	63.5	27	54	81	108	135	162	189	216	243	270	
							34	67	101	135	168	202	236	269	303	337	
					3	76.2	41	82	123	164	205	246	287	328	369	410	
8 8x10x8	200	150-600	8	203	3.5	88.9	52	104	155	207	259	311	362	414	466	518	
							63	126	188	251	314	377	439	502	565	630	
10	250	150-600	9.57	243	4	102	77	155	232	309	387	464	541	618	696	773	
							5	127	95	190	285	380	475	570	665	760	855
12	300	150-600	10.75	273	5.5	140	130	260	390	520	650	780	910	1040	1170	1300	
16	400	600	14.4	366	5	127	186	372	558	745	931	1117	1304	1490	1676	1863	
							7	178	223	452	679	905	1131	1357	1584	1810	2036
18	450	150-600	16.89	429	7.5	191	290	579	869	1158	1448	1737	2027	2316	2606	2895	
20	500	150-300	23	584	11	280	425	851	1276	1701	2127	2552	2978	3403	3829	4254	
24	600	150-300	27	686	12	305	690	1380	2070	2760	3450	4140	4830	5520	6210	6900	
							15	381	753	1506	2259	3012	3765	4518	5271	6024	6777

Note : Consult Baker Hughes Engineering for Lo-dB Equal percentage for High Capacity designs.

# C<sub>v</sub> and F<sub>L</sub> Versus Travel

Single-Stage Lo-dB /Anti-Cavitation

Models: 41335, 41435, 41535, 41635, 41735 and 41935

Flow Characteristic: EQUAL PERCENTAGE

Percent of Travel							10	20	30	40	50	60	70	80	90	110	
F <sub>L</sub>							0.94	0.94	0.94	0.94	0.94	0.94	0.94	0.94	0.94	0.94	0.94
Valve Size		ASME CLASS and equivalent PN	Office Diameter		Travel		Rated C <sub>v</sub>										
in.	mm		in.	mm	in.	mm											
2	50	900-2500	1.84	46.7	0.8	20.3	0.2	0.3	0.6	1	1.6	3	5.2	7.9	9.8	11	
							0.2	0.5	0.9	1.5	2.4	4.4	7.6	11.4	14.2	16	
							0.3	0.7	1.3	2.1	3.4	6.3	11	16.5	20.4	23	
2 3x2 <sup>(1)</sup> 4x2	50 80x50 100x50	150-600	2.5	63.5	1.5	38.1	0.3	0.8	1.5	2.4	3.8	7.1	12.4	18.5	23.1	26	
		150-1500					0.5	1.2	2.2	3.5	5.6	10.4	18.1	27.1	33.8	38	
3	80	2500					0.7	1.7	3.1	4.9	8	14.8	25.8	38.5	48	54	
3 4x3 6x3	80 100x80 150x80	150-1500	3.5	88.9	2	50.8	0.6	1.3	2.7	4.4	7.1	12.8	22.5	33.6	41.6	47	
							0.9	1.9	3.8	6.2	10.1	18.2	32.1	47.9	59.4	67	
4	100	2500					1.2	2.7	5.5	8.9	14.4	26.1	46	68.6	85.1	96	
4 6x4 8x4	100 150x100 200x100	150-1500	4.38	111	2	50.8	0.9	2.2	4	6.2	10.3	19	33.3	49.8	62.2	70	
							1.3	3.1	5.8	8.9	14.7	27.2	47.6	71.2	88.9	100	
6	150	2500					1.9	4.5	8.4	12.9	21.3	39.4	69.1	103.2	128.9	145	
6 8x6 10x6	150 200x150 250x150	150-1500	5.12	130	2.5	63.5	3	6	12	18	27	41	61	82	99	110	
							3.9	9.1	16.9	25.9	37.6	58.3	86.4	116	140.5	155	
8	200	2500					5.7	13.2	24.5	37.7	54.7	84.8	125.4	168.3	203.8	225	
8 10x8 12x8	200 250x200 300x200	150-1500	6.5	165	3	76.2	4	11	19	30	44	67	100	135	163	180	
							6	15	28	44	64	97	145	195	236	260	
10	250	2500					9	22	41	64	92	141	209	281	340	375	
10	250	150-1500	8	203	3.5	88.9	6	14	25	39	56	86	128	172	208	230	
							9	20	37	57	83	128	190	254	308	340	
12	300	2500					12	29	53	82	119	183	270	363	439	485	
12 16x12	300 400x300	150-1500	9.75	248	5	127	10	24	43	67	97	150	222	299	363	400	
							15	34	62	97	140	215	320	430	521	575	
16	400	2500					21	49	89	139	201	309	459	617	748	825	
16	400	150-1500	13	330	6	152	17	39	72	112	162	249	370	497	603	665	
							24	56	103	160	232	356	529	711	861	950	
							34	80	146	228	329	507	752	1009	1223	1350	

1. Ex. 3x2 size = valve with 3" body with standard 2" trim.

Consult Baker Hughes Engineering for Lo-dB Equal Percentage for High Capacity designs.

# C<sub>V</sub> and F<sub>L</sub> Versus Travel

Multi-Stage Lo-dB

Models: 41355, 41555, 41655, 41755 and 41955

Flow Characteristic: FLOW TO OPEN

Percent of Travel							10	20	30	40	50	60	70	80	90	100		
F <sub>L</sub>							0.95	0.95	0.95	0.95	0.95	0.95	0.95	0.95	0.95	0.95	0.95	
Valve Size		ASME CLASS and equivalent PN	Orifice Diameter		Travel		Rated C <sub>V</sub>											
in.	mm		in.	mm	in.	mm												
2	50	900-2500	1.84	46.7	0.8	20.3	1.2	2.4	3.6	4.8	6	7.2	8.4	9.6	10.8	12		
							1.9	3.8	5.7	7.6	9.5	11.4	13.3	15.2	17.1	19		
							2.4	4.8	7.2	9.6	12	14.4	16.8	19.2	21.6	24		
2	50	150-600	2.5	63.5	1.5	38.1	3	6	9	12	15	18	21	24	27	30		
3x2 <sup>(1)</sup>	80x50	150-1500					4	9	13	17	22	26	30	34	39	43		
4x2	100x50	2500					5	11	16	21	27	32	37	42	48	53		
3	80	150-1500	3.5	88.9	2	50.8	5	10	15	20	25	30	35	40	45	50		
							4x3	100x80	8	15	23	30	38	45	53	60	68	75
							6x3	150x80	10	19	29	38	48	57	67	76	86	95
4	100	150-1500	4.38	111	2	50.8	7	14	22	29	36	43	50	58	65	72		
							6x4	150x100	11	21	32	42	53	63	74	84	95	105
							8x4	200x100	13	26	39	52	65	78	91	104	117	130
6	150	150-1500	5.12	139	2.5	63.5	10	19	29	38	48	58	67	77	86	96		
							8x6	200x150	15	30	45	60	75	90	105	120	135	150
							10x6	250x150	19	38	57	76	95	114	133	152	171	190
8	200	150-1500	6.5	165	2.5	63.5	16	31	47	62	78	93	109	124	140	155		
							10x8	250x200	25	50	75	100	125	150	175	200	225	250
							12x8	300x200	30	60	90	120	150	180	210	240	270	300
10	250	2500	3	76.2	30	60	90	120	150	180	210	240	270	300				
10	250	150-1500	8	203	2.5	63.5	23	46	69	92	115	138	161	184	207	230		
							35	70	105	140	175	210	245	280	315	350		
							3	76.2	42	84	126	168	210	252	294	336	378	420
12	300	150-1500	9.75	248	2.5	63.5	38	75	113	150	188	225	263	300	338	375		
							4	102	60	120	180	240	300	360	420	480	540	600
							5	127	73	145	218	290	363	435	508	580	653	725
14	350	150-1500	11.55	293	2.5	63.5	31	96	148	198	246	292	335	386	424	450		
							4	102	66	149	226	301	378	440	508	573	624	678
							5	127	87	201	302	399	489	575	655	736	802	863
16	400	150-1500	13	330	2.5	63.5	50	100	150	200	250	300	350	400	450	500		
							4	102	80	160	240	320	400	480	560	640	720	800
							6	152	111	221	332	442	553	663	774	884	995	1105
18	450	150-1500	14.5	368	3.5	88.9	73	146	219	292	365	438	511	584	657	730		
							5	127	117	234	351	468	585	7002	819	936	1053	1170
							7	178	146	292	438	584	730	876	1022	1168	1314	1460
20	500	150-900	19	483	4	1012	79	422	790	1158	1517	1860	2182	2481	2753	3000		
							6	152	244	792	1343	1866	2342	2762	3124	3431	3688	3900
							9	229	524	1356	2103	2724	3219	3604	3907	4147	4342	4500
24	600	150-600	23	584	4	102	130	260	390	520	650	780	910	1040	1170	1300		
							6	152	190	380	570	760	950	1140	1330	1520	1710	1900
							9	229	280	560	840	1120	1400	1680	1960	2240	2520	2800
							11	279	320	640	960	1280	1600	1920	2240	2560	2880	3200
							15	381	420	840	1260	1680	2100	2520	2940	3360	3780	4200

1. Ex. 3x2 size=valve with 3" body with standard 2" trim

Multi-stage Lo-dB trim is not available for High Capacity designs.

# C<sub>v</sub> and F<sub>L</sub> Versus Travel

Multi-Stage Anti-Cavitation  
Model: 41395

Flow Characteristic: LINEAR

Percent of Travel							10	20	30	40	50	60	70	80	90	100	
F <sub>L</sub>							0.95	0.95	0.95	0.95	0.95	0.95	0.95	0.95	0.95	0.95	0.95
Valve Size		ASME CLASS and equivalent PN	Orifice Diameter		Travel		Rated C <sub>v</sub>										
in.	mm		in.	mm	in.	mm											
2	50	900-2500	1.52	38.6	0.8	20.3	0.9	1.8	2.7	3.6	4.5	5.4	6.3	7.2	8.1	9	
							1.3	2.6	3.9	5.2	6.5	7.8	9.1	10.4	11.7	13	
							1.5	3	4.5	6	7.5	9	10.5	12	13.5	15	
2 3x2 <sup>(1)</sup> 4x2	50 80x50 100x50	150-600	2.15	54.6	1.5	38.1	2.3	4.6	6.9	9.2	12	14	16	18	21	23	
							3.5	7	10.5	14	18	21	25	28	32	35	
3	80	2500					4.4	8.8	13.2	18	22	26	31	35	40	44	
3 4x3 6x3	80 100x80 150x80	150-1500	3.15	80.0	1.5	38.1	4	8	12	16	20	24	28	32	36	40	
							6.5	13	20	26	33	39	46	52	59	65	
4	100	2500					8	16	24	32	40	48	56	64	72	80	
4x3 6x3	100x80 150x80	150-1500	3.15	80.0	2	50.8	9.3	18.6	28	37	47	56	65	74	84	93	
4 6x4 8x4	100 150x100 200x100	150-1500	4.0	102	2	50.8	6.5	13	20	26	33	39	46	52	59	65	
							10.5	21	32	42	53	63	74	84	95	105	
6	150	2500					12.5	25	38	50	63	75	88	100	113	125	
6 8x6 10x6	150 200x150 250x150	150-1500	4.78	121	2.5	63.5	10	20	30	40	50	60	70	80	90	100	
							16	32	48	64	80	96	112	128	144	160	
8	200	2500					20	39	59	78	98	117	137	156	176	195	
8 10x8 12x8	200 250x200 300x200	150-1500	6.15	156	2.5	63.5	17	34	51	68	85	102	119	136	153	170	
							26	52	78	104	130	156	182	208	234	260	
10	250	2500			3	76.2	32	64	96	128	160	192	224	256	288	320	
10	250	150-1500	7.63	194	2.5	63.5	23	46	69	92	115	138	161	184	207	230	
							88.9	38	76	114	152	190	228	266	304	342	380
12	300	2500			3.5	88.9	45	90	135	180	225	270	315	360	405	450	
12 16x12	300 400x300	150-1500	9.37	238	2.5	63.5	40	80	120	160	200	240	280	320	360	400	
							64	128	192	256	320	384	448	512	576	640	
16	400	2500			5	127	80	160	240	320	400	480	560	640	720	800	
16	400	150-1500	13	330	2.5	63.5	60	120	180	240	300	360	420	480	540	600	
							95	190	285	380	475	570	665	760	855	950	
							131	262	393	524	655	786	917	1048	1179	1310	

1. Ex. 3x2 size= valve with 3" body with standard 2" trim

# C<sub>V</sub> and F<sub>L</sub> Versus Travel

Variable Resistance Trim (VRT) Type S  
Model: 41365

Flow Characteristic: LINEAR

Percent of Travel								10	20	30	40	50	60	70	80	90	100
F <sub>L</sub>								0.999	0.999	0.999	0.998	0.997	0.996	0.994	0.992	0.990	0.988
Valve Size		ASME CLASS and equivalent PN	Orifice Diameter		Travel		Minimum Operable C <sub>V</sub>	Rated C <sub>V</sub>									
in.	mm		in.	mm	in.	mm											
8	200	300 - 1500	2.99	75.9	4	102	2.1	12	24	36	48	60	72	84	96	108	120
10	250	300 - 1500	4.11	104	4	102	2.3	19	38	57	76	95	114	133	152	171	190
12	300	300 - 1500	4.91	125	4	102	2.8	27	54	81	108	135	162	189	216	243	270

# C<sub>V</sub> and F<sub>L</sub> versus Travel

Variable Resistance Trim (VRT) Partial Stack Type S  
Model: 41375

Flow Characteristic: MODIFIED LINEAR

Percent of Travel								10	20	30	40	50	60	70	80	90	100	
Valve Size		ASME CLASS and equivalent PN	Orifice Diameter		Travel		Minimum Operable C <sub>V</sub>	Rated C <sub>V</sub>										
in.	mm		in.	mm	in.	mm												
3	80	150-1500	2.42	61.5	2.5	63.5	1.0	C <sub>V</sub>	7	11	15	23	33	42	54	67	83	95
4	100	2500						FI	0.998	0.996	0.991	0.98	0.958	0.927	0.92	0.92	0.92	0.92
4	100	150-1500	2.99	75.9	2.5	63.5	1.3	C <sub>V</sub>	7	11	17	25	36	52	66	86	113	140
6	150	2500						FI	0.998	0.996	0.991	0.98	0.956	0.927	0.92	0.92	0.92	0.92
6	150	150-1500	3.99	101	3.5	88.9	1.8	C <sub>V</sub>	14	22	35	57	82	115	163	210	245	270
8	200	2500						FI	0.998	0.995	0.987	0.969	0.929	0.92	0.92	0.92	0.92	0.92
8	200	150-1500	5.36	136	4	102	3.8	C <sub>V</sub>	22	38	58	99	140	192	280	360	425	480
10	250	2500						FI	0.998	0.994	0.984	0.962	0.926	0.92	0.92	0.92	0.92	0.92
10	250	150-1500	7.49	190	4	102	3.9	C <sub>V</sub>	22	43	65	110	165	240	375	520	640	750
12	300	2500						FI	0.998	0.994	0.982	0.956	0.923	0.92	0.92	0.92	0.92	0.92

Note: Throttling at less than minimum operable C<sub>V</sub> levels for extended period of time can result in trim damage.



# Body S/A Construction

Models 41X15, 41X25, 41X35, 41X45, 41X55, 41X95, 41XA5, 41XB5, and 41XC5

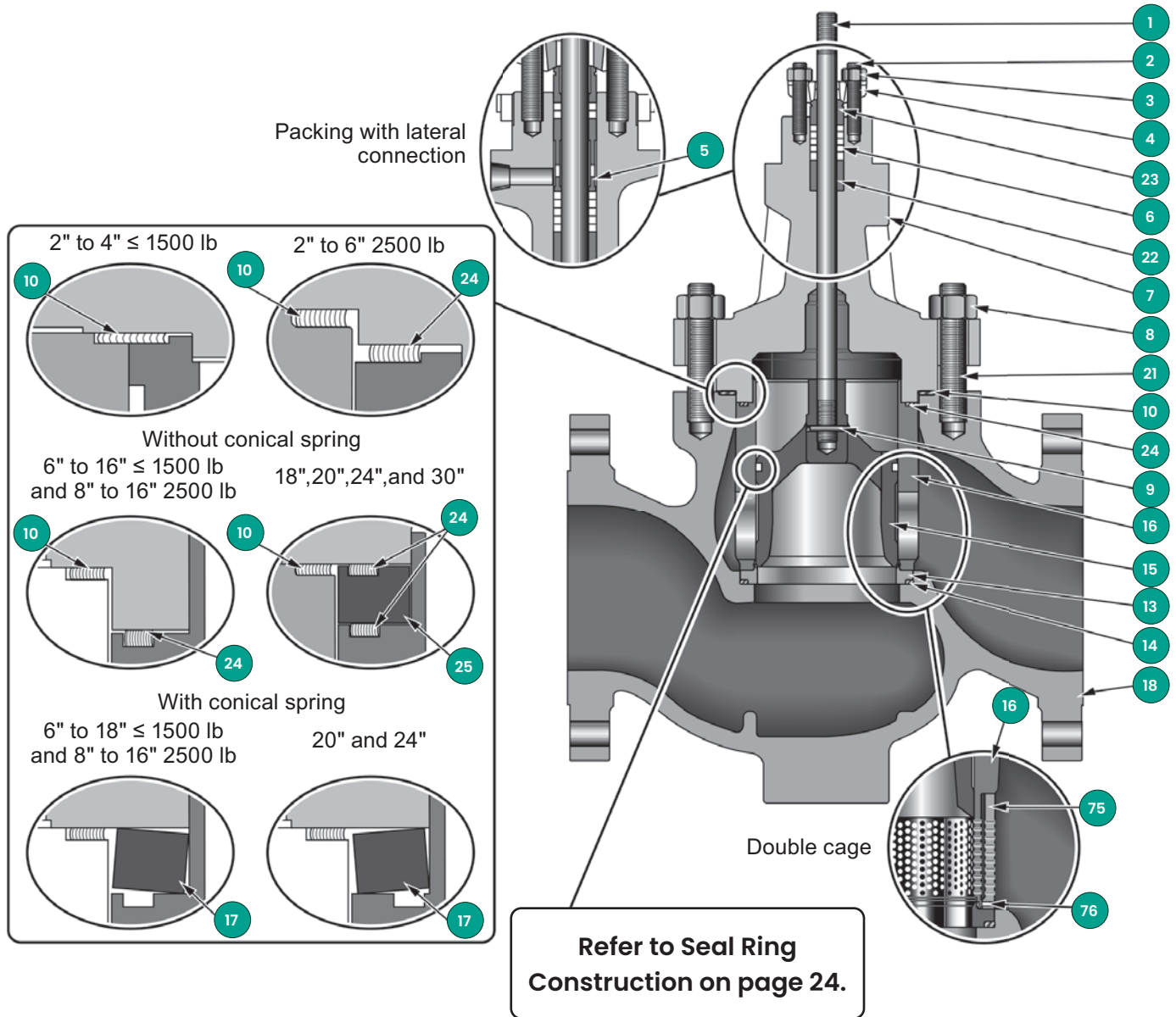

Note: 6" through 24" High Capacity designs are not available with conical spring construction.

# Body S/A Construction

Models 41X15, 41X25, 41X35, 41X45, 41X55, 41X95, 41XA5, 41XB5 and 41XC5

Ref. No.	Part Name
1	Valve Plug Stem
2	Packing Flange Stud
3	Packing Flange Nut
4	Packing Flange
5	Packing Spacer
●	6 Packing
7	Bonnet
8	Valve Body Nut
9	Plug Stem Pin
●	10 Body Gasket
*	12 Pilot Spring(s)
13	Seat Ring
●	14 Seat Ring Gasket
15	Valve Plug (or Piston)
16	Cage
+	17 Conical Spring
18	Valve Body
*	19 Retaining Ring
*	20 Auxiliary Pilot Plug
21	Valve Body Stud
22	Guide Bushing
23	Packing Follower
●	24 Cage Gasket
⊕ ●	31 Tec Seal
○ ●	35 Ni-resist® Seal Ring
★ ●	40 PTFE Seal Ring
★ ●	41 Nordel® Backup Ring
▲	42 High Temp Seal
□ ●	45 Graphite Seal Ring
●	46 Ni-resist® Backup Ring
75	Double cage
76	Pin

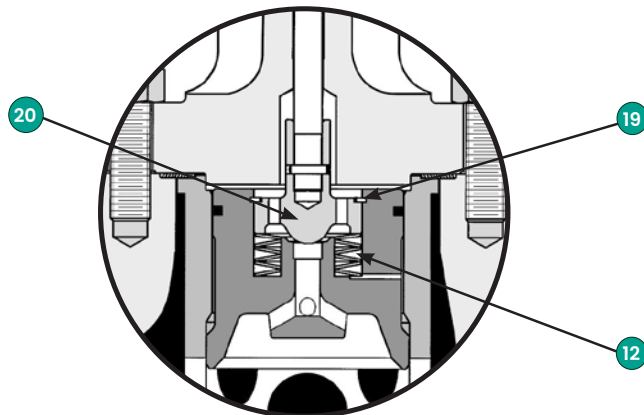

**Pilot Balanced Construction Model 41405**  
**Sizes 2" to 4" shown**

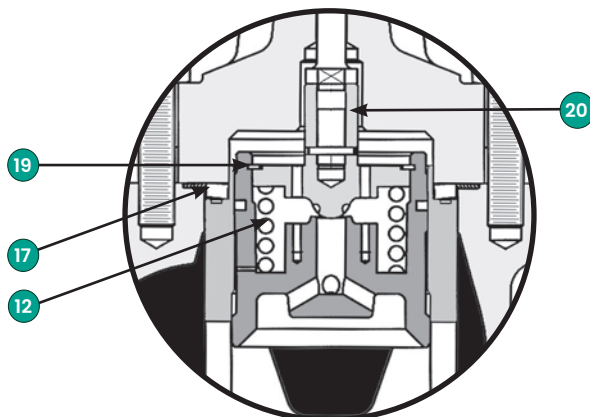

**Pilot Balanced Construction Model 41405**  
**Applications above 450°F to 1050°F**  
**(232°C to 566°C)**  
**Sizes 6" to 18" shown**

- \* For 41405 Series Valves only
- + For all valve sSizes above 450°F (232°C)
- ★ For 41605 Series Valves only
- Recommended Spare Parts
- ▲ For use with 41705 Series Valves only
- For 41905 Series Valves only
- For 41405 / 41505 Series Valves only
- ⊕ For 41305 Series Valves only

Note: 6" through 24" High Capacity designs are not available with pilot construction.

# Materials of Construction

Models 41X15, 41X25, 41X35, 41X45, 41X55, & 41X95

Models 41XA5, 41XB5 & 41XC5 limited to 575°F for sizes 6" and 8" and limited to 450°F for sizes 10" to 24" High

Capacity designs

Standard Carbon Steel Version

Ref. No	Temperature Range		-20°F (-29°C)	450°F (232°C)	650°F (343°C)	800°F (427°C)
	Description		Standard Materials			
1	Plug Stem		17-4 PH St. St. ASTM A564 GR 630			See Optional Materials
2	Packing Flange Stud		304 St. St. ASTM A193 GR B8			
3	Packing Flange Nut		304 St. St. ASTM A194 GR 8			
4	Packing Flange		Carbon Steel ASTM A105 Zinc Plated			
5	Packing Spacer		303 St. St. ASTM A582 TY 303			
6	Packing		Carbon Core Braided PTFE (ASME Class 150-900) PTFE/Carbon + Braided Graphite End Rings (ASME Class 1500-2500) For use with standard length bonnet			See Optional Materials
7	Valve Bonnet		Carbon Steel ASTM A216 Grade WCC			
8	Valve Body Nut		Carbon Steel ASTM A194 GR 2H			
9	Plug Stem Pin		316 St. St. ASTM A479 TY 316			
10	Valve Body Gasket		316L St. St. w/Flexible Graphite Filler (Spiral Wound)			
12	Pilot Spring(s) (41405 Only)	2" to 4"	Inconel X-750 AMS 5598 (Stacked Washers)			
		6" to 16"	Inconel X-750 ASTM B637 GR 688			
13	Seat Ring		410 St. St. ASTM A479 TY 410 Hardened			See Optional Materials
14	Seat Ring Gasket		316L St. St. w/Flexible Graphite Filler (Spiral Wound)			
15	Valve Plug		17-4 PH St. St. ASTM A747 GR CB7CU-1 Condition HI075			See Optional Materials
16	Cage		Martensitic St. St. ASTM A487 GR CA6NM CL B Hard Chrome Plated			See Optional Materials
17	Conical Spring <sup>(1)</sup> (6" to 24")		See Note 1	17-4 PH ASTM A564 GR 630 Condition HI075		Inconel X-750 ASTM B637 + Shot Peening
18	Valve Body		Carbon Steel ASTM A216 Grade WCC			
19	Retaining Ring (41405 Only)		Inconel X-750 AMS 5598			
20	Auxiliary Pilot Plug (41405 Only)	2" to 4"	410 St. St. ASTM A479 TY 410 Hardened			
		6" to 16"	Martensitic St. St. ASTM A487 GR CA6NM CL B with Chrome Plated Guide and Hardfaced Seat			
21	Valve Body Stud		Alloy Steel ASTM A193 GR B7			
22	Guide Bushing		440C St. St. ASTM A276 TY 440C			
23	Packing Follower		Solution Annealed 316L St. St. Hrc 22 Maximum			
-	Internal Diffuser <sup>(2)</sup> (6" to 24")		316 St. St. ASTM A479 TY 316 with Hardfaced Seat			
24	Cage Gasket <sup>(3)</sup>		316L St. St. w/Flexible Graphite Filler (Spiral Wound)			See Note 3
30	Retainer		17-4 PH St. St. HI075			
31	Seal Ring		See Page 24			
35						
40						
41						
42						
45						
46						

1. Conical spring only required for valve sizes 6" to 24" for applications > 450°F (232°C) and no conical spring available for any High Capacity designs.
2. Internal Diffuser includes an internal 316SS Seat Ring with hardfaced seat. This part replaces the Seat Ring (Ref. No. 13) when this option is selected. See graphic on page 15.
3. Cage gasket only required for valve sizes 6" to 24" for applications ≤ 450°F (232°C) and all applications for 2" to 6" ASME 2500 Class ratings only.

# Materials of Construction

Models 41X15, 41X25, 41X35, 41X45, 41X55 and 41X95

Models 41XA5, 41XB5 and 41XC5 limited to 575°F for sizes 6" and 8" and limited to 450°F for sizes 10" to 24" High Capacity designs.

## Standard Stainless Steel Version<sup>(1)</sup>

Ref. No	Temperature Range	-320°F (-196°C)	-148°F (-100°C)	-50°F (-46°C)	-20°F (-29°C)	450°F (232°C)	650°F (343°C)	800°F (427°C)	850°F (454°C)	950°F (510°C)	1050°F (566°C)
		Standard Materials									
1	Plug Stem	See Optional Materials		316 St. St. ASTM A479 TY 316			See Optional Materials				
7 18	Valve Bonnet <sup>(2)</sup> Valve Body	316 St. St. ASTM A351 GR CF8M									
13	Seat Ring	316 St. St. ASTM A479 TY 316 with Hardfaced Seat									
15	Valve Plug	316 St. St. ASTM A479 TY 316 with Hardfaced Seat									
16	Cage	316 St. St. ASTM A479 TY 316 Chrome-Plated					See Optional Materials				
17	Conical Spring (6" to 16") <sup>(3)</sup>	See Optional Materials				Inconel X-750 ASTM B637 + Shot Peening					
20	Auxiliary Pilot Plug (41X5) Only	316 St. St. ASTM A479 TY 316 with Chrome Plated Guide and Hardfaced Seat									
22	Guide Bushing	316 St. St. ASTM A479 TY 316 with Hardfacing Stellite or Equivalent 6 UNS 30006 (HRC 22 Max.)									
21	Valve Body Stud				ASTM A193 GR B7 – ZINC PLATING		A 193 Gr B7	ASTM A 193 Gr B16 <sup>(6)</sup>			
		ASTM A320 GR L7 ZINC PLATING									
		ASTM A 193 GR B8 class 2 (optional for 2" and 3" ASME class 300 and 600 only)									
		ASTM A453 GRADE 660 or ASTM A193 GRADE B8RA <sup>(4)</sup>									
8	Valve Body Nut				ASTM A194 GR 2H – ZINC PLATING		A 194 Gr 2H				
		ASTM A194 GR 7 – ZINC PLATING									
		ASTM A 194 Gr 8 (optional for 2" and 3" ASME class 300 and 600 only)									
		ASTM A 194 Gr 8 <sup>(4)</sup>									
30	Retainer	17-4 PH St. St. H1075 Hardfacing Stellite No. 6 on 316 St. St.									

- Materials for other components are same as listed for Standard Carbon Steel Version.
- Extension bonnet : use a low temperature extension bonnet between -46°C and -100°C. Use a cryogenic bonnet between -101°C and 196°C.
- Conical spring only required for valve sizes 6" to 24" for applications > 450°F (232°C).
- Bolting must be checked by the Engineering Department.
- See Optional Bolting Materials Table for temperatures >510 °C .

## Optional Configurations and Materials

Ref. No.	Temperature Range	-320°F (-196°C)	-100°F (-73°C)	-50°F (-46°C)	-20°F (-29°C)	650°F (343°C)	800°F (427°C)	1050°F (566°C)	
		Optional Materials							
1	Plug Stem	A286 Super Alloy ASTM A638 GR 660							
6	Packing	Teflon V-Ring For use with Cryogenic bonnet	Carbon Core Braided PTFE (ASME Class 150-900)		Carbon Core Braided PTFE (ASME Class 150-900)		Carbon Core Braided PTFE (ASME Class 150-900)		
			PTFE/Carbon + Braided Graphite End Rings (ASME Class 1500-2500)		PTFE/Carbon + Braided Graphite End Rings (ASME Class 1500-2500)		PTFE/Carbon + Braided Graphite End Rings (ASME Class 1500-2500)		
		For use with extended length bonnet		For use with standard length bonnet		For use with standard length bonnet		For use with extended length bonnet	
						Low-E Packing <sup>(1)</sup> For use with standard length bonnet			
								Flexible Graphite / For use with standard length bonnet.	
7	Valve Bonnet							Chrome-Moly Steel ASTM A217 Grade WC6 or Grade WC9	
18	Valve Body							Carbon Steel ASTM A 352 Grade LCC	
13	Seat Ring	2" to 4"	316 St. St. ASTM A479 TY 316 with Hardfaced Seat						
		6" to 16"	Martensitic St. St. ASTM A487 GR CA6NM CL A with Hardfaced Seat						
15	Valve Plug	Martensitic St. St. ASTM A487 GR CA6NM CL B Nitride							
16	Cage	Martensitic St. St. ASTM A487 GR CA6NM CL B Nitrided							
		316 St. St. ASTM A479 TY 316 Nitrided							

- Low Emissions packing options and application guidelines are available in Tech Spec titled Masoneilan Low-E Packing Series, Ref. 32991.

# Materials of Construction

## Optional Bolting Materials

Ref. No.	Temperature Range	-320°F to -150°F (-196°C to -101°C)	-150°F to -20°F (-101°C to -29°C)	850°F to 950°F (454°C to 510°C)	950°F to 1050°F (510°C to 566°C)
	Description	Optional Materials			
8	Valve Body Nut <sup>(1 &amp; 2)</sup>	304 SS ASTM A194 Grade 8	Alloy Steel ASTM A194 Grade 4	Alloy Steel ASTM A194 Grade 8	304 SS ASTM A194 Grade 8
21	Valve Body Stud <sup>(1 &amp; 2)</sup>	Super Alloy ASTM A453 Grade 660	Alloy Steel ASTM A320 Grade L7	Alloy Steel ASTM A193 Grade B16	Super Alloy ASTM A453 Grade 660

- Use following materials for 2" and 3" sizes ASME Class 300/600 at temperatures below -20°F (-29°C).  
Studs - 304 SS ASTM A193 Grade B8 Class 2 • Nuts - 304 SS ASTM A194 Grade 8.
- For high temperature use the following materials:  
Studs- ASTM A193 GRADE B8RA (for NACE) • Nuts-ASTM A 194 Gr 2HM (for NACE)  
Studs-ASTM B637 N07718 INCONEL 718 • Nuts- ASTM A 194 Gr 8.

### Additional Material Options:

The 41005 Series is also available in the following body materials with appropriate trim and bolting options.

A351 Grade CF3M	A995 Grade 4A	A217 Grade C5
A351 Grade CF8C	A995 Grade 6A	A217 Grade C12A
Monel ASTM A 484 Grade M35-1		

Products in these materials can be fully configured in ValvStream.  
Consult Baker Hughes for appropriate material combinations.

# Materials of Construction

NACE<sup>(1)</sup> Configuration and Material Options

Models 41X15, 41X25, 41X35, 41X45, 41X55 and 41X95

Model 41XA5, 41XB5 and 41XC5 limited to 575°F for sizes 6" and 8"

and limited to 450°F for sizes 10" to 24" High Capacity designs

Ref. No	Temperature Range		-20°F (-29°C)	800°F (427°C)
	Description		Standard and Optional Materials	
1	Plug Stem		316 St. St. ASTM A479 TY 316 (HRC 22 Max.)	
			Super Alloy ASTM A638 GR 660 (HRC 35 Max.)	
2	Packing Flange Stud		304 St. St. ASTM A193 GR B8 <sup>(2)</sup>	
			304 St. St. ASTM A193 Gr B8 <sup>(3)</sup> (HRC 22 Max.)	
3	Packing Flange Nut		304 St. St. ASTM A194 GR 8 <sup>(2)</sup>	
			304 St. St. ASTM A194 GR 8A <sup>(3)</sup> (HRC 22 Max.)	
4	Packing Flange		Corrosion Protected Carbon Steel (HRC 22 Max.)	
5	Packing Spacer		304 St. St. ASTM A479 TY 304	
6	Packing		Carbon Core Braided PTFE (ASME Class 150-900)	
			PTFE/Carbon + Braided Graphite End Rings (ASME Class 1500-2500) For use with standard length bonnet	
7	Valve Bonnet		Carbon Steel ASTM A216 Grade WCC (HRC 22 Max.)	
			Carbon Steel ASTM A105 (HRC 22 Max.)	
			316 St. St. ASTM A351 Gr CF8M (HRC 22 Max.)	
8	Valve Body Nut		Alloy Steel ASTM A194 GR 2H <sup>(2)</sup>	
			Alloy Steel ASTM A194 Gr 2HM <sup>(3)</sup>	
9	Plug Stem Pin		316 St. St. ASTM A479 TY 316 (HRC 22 Max.)	
10	Valve Body Gasket		316L St. St. w/Flexible Graphite Filler (Spiral Wound)	
12	Pilot pring(s) (41405 Only)	2" to 4"	Inconel X-750 AMS 5598 (HRC 50 Max.)	
		6" to 16"	Inconel X-750 ASTM B637 GR 688 (HRC 50 Max.)	
13	Seat Ring		316 St. St. ASTM A479 TY 316 with Hardfaced Seat (HRC 22 Max.)	
14	Seat Ring Gasket		316L St. St. w/Flexible Graphite Filler (Spiral Wound)	
15	Valve Plug		316 St. St. ASTM A479 TY 316 with Hardfaced Seat (HRC 22 Max.)	
			Martensitic St. St. ASTM A487 GR CA6NM CL B (HRC 22 Max.)	
16	Cage		316 St. St. ASTM A479 TY 316 Hard Chrome Plated (HRC 22 Max.)	
			Martensitic St. St. ASTM A487 GR CA6NM CL B Hard Chrome Plated (HRC 23 Max.)	
17	Conical Spring <sup>(1)</sup> (6" to 24")		Inconel X-750 ASTM B637 + Shot Peening	
18	Valve Body		Carbon Steel ASTM A216 Grade WCC (HRC 22 Max.)	
			316 St. St. ASTM A351 Gr CF8M (HRC 22 Max.)	
19	Retaining Ring (41405 Only)		Inconel X-750 AMS 5598 (HRC 50 Max.)	
20	Auxiliary Pilot Plug (41405 Only)		316 St. St. ASTM A479 TY 316 with Hardfaced Seat (HRC 22 Max.)	
			Martensitic St. St. ASTM A487 GR CA6NM CL B Chrome Plated Guide and Hardfaced Seat (HRC 23 Max.)	
21	Valve Body Stud		Alloy Steel ASTM A193 GR B7 <sup>(2)</sup>	
			Alloy Steel ASTM A193 Gr B7M <sup>(3)</sup>	
22	Guide Bushing		Stelliteor Equivalent 6 UNS 30006 (HRC 22 Max.)	
			316 St. St. ASTM A479 TY 316 with Hardfacing (HRC 22 Max.)	
23	Packing Follower		316 St. St. ASTM A479 TY 316 (HRC 22 Max.)	
-	Internal Diffuser <sup>(2)</sup> (6" to 24") (not shown)		316 St. St. ASTM A479 TY 316 with Hardfaced Seat (HRC 22 Max.)	
24	Cage Gasket <sup>(3)</sup>		316L St. St. w/Flexible Graphite Filler (Spiral Wound)	
30	Retainer		CA6NM ASTM 487 Gr CA 6 NM Class B	
			Hardfacing Stellite No. 6 on 316 St. St.	
31	Seal Ring		See Page 24 & 25	
35				
40				
41				
42				
45				
46				
-	Drive Nut (not shown)		Carbon Steel SAE 1117 <sup>(2)</sup>	
			Carbon Steel ASTM A105 or SAE 1010-1025 <sup>(3)</sup>	

1. Standard materials and processes are in accordance with the requirements of NACE specification MR0103. Applications requiring compliance to MR0175-2003 or ISO15156 must be reviewed by Masonellan.

2. Materials designated for these parts conform to NACE Class III bolting requirements. (Non-Exposed)

3. Materials designated for these parts conform to NACE Class I or Class II bolting requirements. (Exposed)

4. Cage gasket only required for valve sizes 6" to 24" for applications ≤ 450°F (232°C) and all applications for 2" to 6" ASME 2500 Class ratings only.

5. Seal ring materials for Model 41605 (PTFE Seal Ring) will be replaced with Glass-Reinforced PTFE External Seal Ring (Ref. No. 40) and Viton Internal Seal Ring (Ref. No. 41). Maximum temperature for Models 41305 and 41605 limited to 450°F (232°C).

# Trim Types

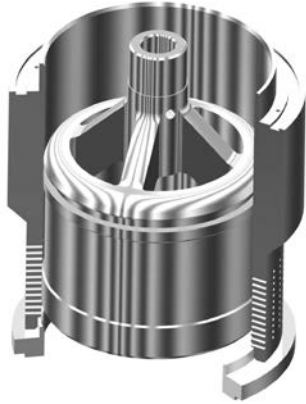

**Models 41335 - 41535 - 41635 - 41735 - 41935**  
**413C5 - 415C5 - 416C5 - 419C5**  
 Single Stage Low Noise Trim FTO  
 Anti-Cavitation Trim FTC

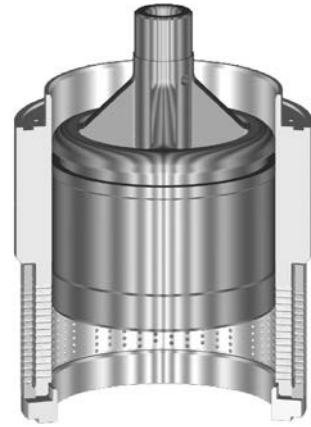

**Models 41355 - 41555 - 41655 - 41755 - 41955**  
 Multi-Stage Low Noise Trim FTO

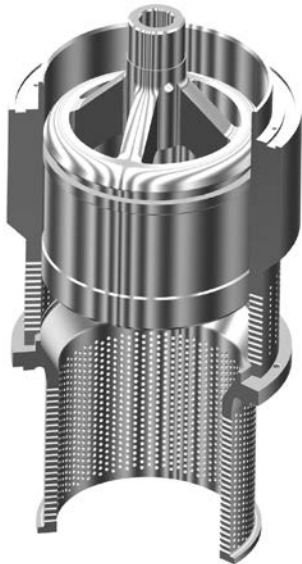

**Model 41045**  
 Single Stage with Internal Diffuser  
 (Sizes 6" - 24")



**Models 41395 - 41595 - 41695 - 41795 - 41995**  
 Multi-Stage Anti-Cavitation Trim FTC

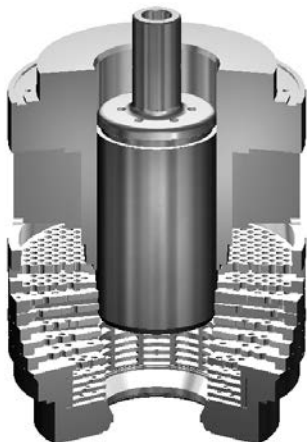

**Model 41365 - 41375**  
 High Pressure Anti-Cavitation VRT

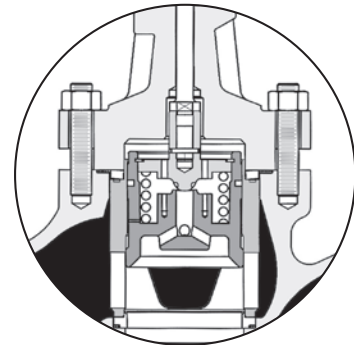

**Model 41405**  
 Pilot Balanced Construction FTC

# Seal Ring Construction

## Model 41305

Seal Type:  
Pressure Energized  
Polymeric

Leakage:  
Class IV Standard  
(Class V Optional)

Temperature:  
-148°F (-100°C) to  
+450°F (+232°C)

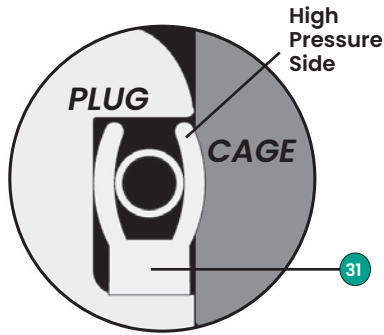

Seal Shown in FTO Orientation

## Models 41405 and 41505

Seal Type:  
Metal

Leakage:  
From Class II to  
Class V (with pilot)

Temperature:  
-320°F (-196°C) to  
+1099°F (+592°C)

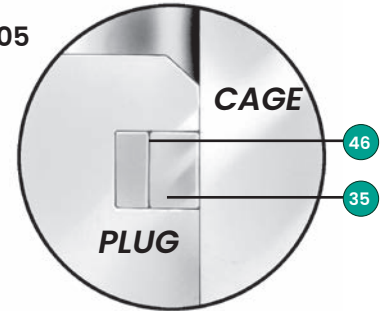

## Model 41305<sup>(1 & 2)</sup>

Optional High  
Temperature Version  
(non VRT)

Seal Type:  
Pressure Energized  
Polymeric

Leakage:  
Class IV Standard  
(Class V Optional)

Temperature:  
-148°F (-100°C) to  
+575°F (+302°C)

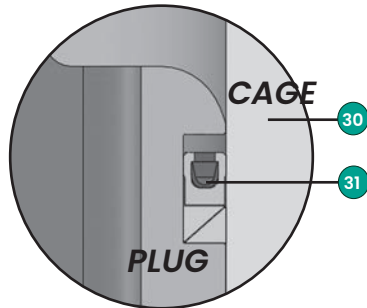

## Model 41605

Seal Type:  
TFE and Resilient Inner

Leakage:  
Class IV Standard

Temperature:  
-20°F (-29°C) to  
+300°F (+149°C)

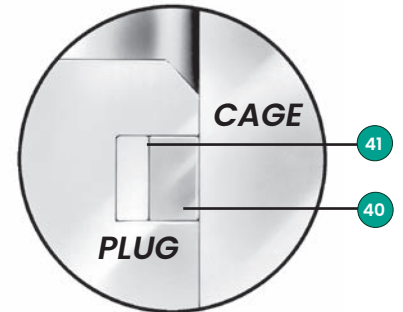

## Model 41705

Seal Type:  
Metal

Leakage:  
Class V

Temperature: (FTO)  
-20°F (-29 C) to  
+850°F (+454°C)

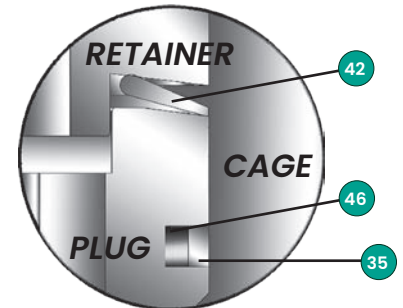

## Model 41905

Seal Type:  
Graphite and Metal Inner

Leakage:  
Class III and  
Class IV Standard

Temperature:  
-320°F (-196°C) to  
+850°F (+454°C)

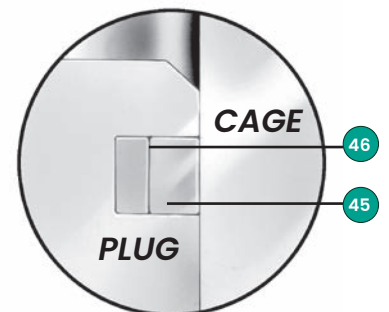

1. Optional high temperature seal for 41305 non-VRT applications.
2. FTO & FTC capable.
3. For all plug seal ring types, 3" and 4" sizes are limited to 800°F (427°C).



# Seal Ring Construction

Ref. No.	Temperature Range	-320°F (-196°C)    -148°F (-100°C)    -20°F (-29°C)    300°F (+149°C)    450°F (+232°C)    575°F (+302°C)    650°F (+343°C)    850°F (+454°C)    1099°F (+593°C)									
		Description	Materials								
31	Seal Ring	PTFE + 25% Graphite and ELGILOY Spring									
	Seal Ring							Fluoroloy A21 <sup>(3)</sup>			
35	External Seal Ring	NiResist ASTM A439 Type D3						Nitrided CA6NM			
40	External Seal Ring			Bronze PTFE							
				Glass Reinforced PTFE <sup>(1)</sup>							
41	Internal Seal Ring			Nordel							
				Viton <sup>(1 &amp; 2)</sup>							
42	High Temp. Seal	Surface Hardened Inconel 718									
45	External Seal Ring	Graphite									
46	Internal Seal Ring	NiResist ASTM A439 Type D3									

1. Optional materials for NACE service. Viton not recommended for water or steam service.
2. Viton is recommended for oil and hydrocarbon service.
3. Optional high temperature seal for 41365 and 41375 VRT.
4. For all plug seal ring types, 3" and 4" sizes are limited to 800°F (427°C).

# Materials of Construction

Models 41365 and 41375 VRT

Ref. No	Part Name
1	Plug Stem
2	Packing Flange Stud
3	Packing Flange Nut
4	Packing Flange
5	Packing Spacer
• 6	Packing
7	Valve Bonnet
8	Valve Body Nut
9	Plug Stem Pin
• 10	Valve Body Gasket
• 11	Seal Ring
13	Seat Ring
• 14	Seat Ring Gasket
15	Valve Plug
16	Cage
18	Valve Body
21	Valve Body Stud
22	Guide Bushing
23	Packing Follower
• 24	Cage Gasket
28	Retaining Ring
29	Retaining Ring
37	Stack
•	<b>Recommended Spare Parts</b>

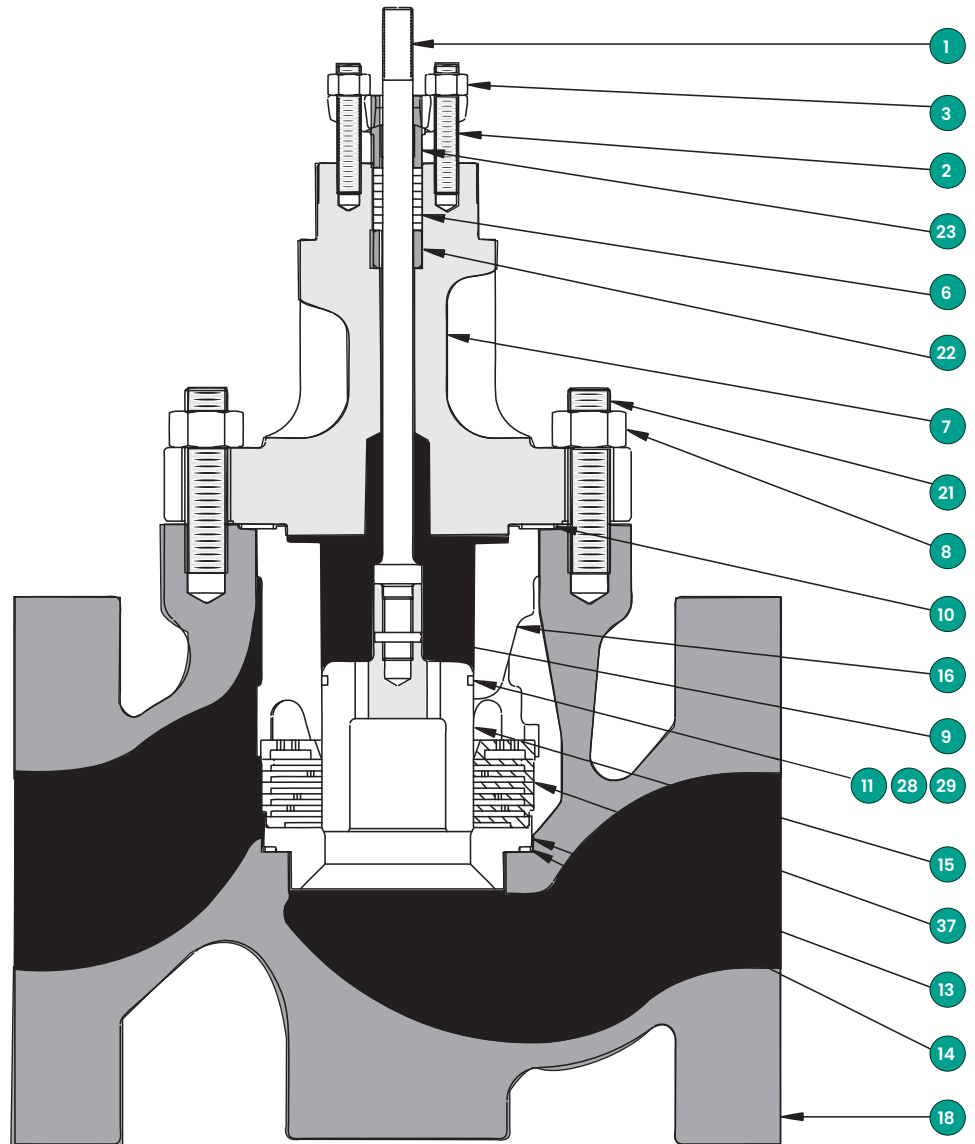

# Materials of Construction

Models 41365 and 41375 VRT  
Standard Carbon Steel Version

Ref. No	Temperature Range	-20°F (-29°C)		450°F (232°C)		600°F (316°C)		
		Description		Standard Materials				
1	Plug Stem	174 PH St. St. ASTM A564 GR 630						
2	Packing Flange Stud	304 St. St. ASTM A193 GR B8						
3	Packing Flange Nut	304 St. St. ASTM A194 GR 8						
4	Packing Flange	Carbon Steel ASTM A105 Zinc Plated						
5	Packing Spacer	303 St. St. ASTM A582 TY 303						
6	Packing	Carbon Core Braided PTFE (ASME Class 150-900) PTFE/Carbon + Braided Graphite End Rings (ASME Class 1500-2500) For use with standard length bonnet						
7	Valve Bonnet	Carbon Steel ASTM A216 Grade WCC						
8	Valve Body Nut	Carbon Steel ASTM A194 GR 2H						
9	Plug Stem Pin	316 St. St. ASTM A479 TY 316						
10	Valve Body Gasket	316L St. St. w/Flexible Graphite Filler (Spiral Wound)						
11	Seal Ring	Standard	PTFE + Graphite (25%) with ELGILOY Spring					
		Optional				Fluoroloy A21		
13	Seat Ring	410 St. St. ASTM A479 TY 410 Hardened						
14	Seat Ring Gasket	316L St. St. w/Flexible Graphite Filler (Spiral Wound)						
15	Valve Plug	3" to 6"	440C St. St. ASTM A276 TY 440C					
		8" and 10"	17-4 PH St. St. ASTM A747 Gr CB7CU-1 Condition H900					
16	Cage	Martensitic St. St. ASTM A487 GR CA6NM CL B Hard Chrome Plated						
18	Valve Body	Carbon Steel ASTM A216 Grade WCC						
21	Valve Body Stud	Alloy Steel ASTM A193 GR B7						
22	Guide Bushing	440C St. St. ASTM A276 TY 440C						
23	Packing Follower	303 St. St. ASTM A582 TY 303						
24	Cage Gasket <sup>3</sup>	316L St. St. w/Flexible Graphite Filler (Spiral Wound)						
28	Retaining Ring					ASTM A564 Gr 632 H950 St. St		
29	Retaining Ring					316 St. St. ASTM A479 TY 316		
30	Retaining Ring	Hardfacing Stellite No.6 on 316 Stainless Steel ASTM A487 Gr CA 6 NM Class B 17-4 PH Stainless Steel H1075 ASTM A479 UNS S31803 + Chrome Plating ASTM A479 UNS S31803 + Hardfacing						
37	Stack	Inconel 718						

# Materials of Construction

Models 41365 and 41375 VRT  
Standard Stainless Steel Version

Ref. No	Temperature Range	-20°F (-29°C)	450°F (232°C)
	Description	Standard Materials	
1	Plug Stem	A286 Super Alloy ASTM A638 GR 660	
2	Packing Flange Stud	304 St. St. ASTM A193 GR B8	
3	Packing Flange Nut	304 St. St. ASTM A194 GR 8	
4	Packing Flange	Carbon Steel ASTM A105 Zinc Plated	
5	Packing Spacer	303 St. St. ASTM A582 TY 303	
6	Packing	Carbon Core Braided PTFE (ASME Class 150-900) PTFE/Carbon + Braided Graphite End Rings (ASME Class 1500-2500) For use with standard length bonnet	
7	Valve Bonnet	316 St. St. ASTM A351 GR CF8M	
8	Valve Body Nut	Carbon Steel ASTM A194 GR 2H	
9	Plug Stem Pin	316 St. St. ASTM A479 TY 316	
10	Valve Body Gasket	316L St. St. w/Flexible Graphite Filler (Spiral Wound)	
11	Seal Ring	PTFE + Graphite (25%) with ELGILOY Spring	
13	Seat Ring	316 St. St. ASTM A479 TY 316 with Hardfaced Seat	
14	Seat Ring Gasket	316L St. St. w/Flexible Graphite Filler (Spiral Wound)	
15	Valve Plug	316 St. St. ASTM A479 TY 316 with Hardfaced Seat	
16	Cage	316 St. St. ASTM A479 TY 316 Chrome-Plated	
18	Valve Body	316 St. St. ASTM A351 GR CF8M	
21	Valve Body Stud	Alloy Steel ASTM A193 GR B7	
22	Guide Bushing	316 St. St. ASTM A479 TY 316 with Hardfacing	
23	Packing Follower	303 St. St. ASTM A582 TY 303	
24	Cage Gasket <sup>3</sup>	316L St. St. w/Flexible Graphite Filler (Spiral Wound)	
28	Retaining Ring	ASTM A564 Gr 632 H950 St. St.	
29	Retaining Ring	316 St. St. ASTM A479 TY 316	
37	Stack	Inconel 718	

Note: Materials for other components are as listed for Standard Carbon Steel Version.

# Materials of Construction

NACE<sup>(1)</sup> Configuration and Material Options  
Models 41365 and 41375 VRT

Ref. No	Temperature Range		-20°F (-29°C)	450°F (232°C)	600°F (316°C)
	Description		Standard Materials		
1	Plug Stem		A286 Super Alloy ASTM A638 GR 660		
2	Packing Flange Stud		304 St. St. ASTM A193 GR B8 <sup>(2)</sup> 304 St. St. ASTM A193 GR B8 <sup>(3)</sup> (HRC 22 Max.)		
3	Packing Flange Nut		304 St. St. ASTM A194 GR 8 <sup>(2)</sup> 304 St. St. ASTM A194 GR 8A <sup>(3)</sup> (HRC 22 Max.)		
4	Packing Flange		Corrosion Protected Carbon Steel (HRC 22 Max.)		
5	Packing Spacer		304 St. St. ASTM A479 TY 304		
6	Packing		Carbon Core Braided PTFE (ASME Class 150-900) PTFE/Carbon + Braided Graphite End Rings (ASME Class 1500-2500) For use with standard length bonnet		
7	Valve Bonnet		Carbon Steel ASTM A216 Grade WCC (NRC 22 Max.)		
			316 St. St. ASTM A351 Gr CF8M (HRC 22 Max.)		
8	Valve Body Nut		Carbon Steel ASTM A194 GR 2H <sup>(2)</sup> Carbon Steel ASTM A194 GR 2HM <sup>(3)</sup>		
9	Plug Stem Pin		316 St. St. ASTM A479 TY 316 (HRC 22 Max.)		
10	Valve Body Gasket		316L St. St. w/Flexible Graphite Filler (Spiral Wound)		
11	Seal Ring	Standard	PTFE + Graphite (25%) with ELGILOY Spring		
		Optional			Fluoroloy A21
13	Seat Ring		316 St. St. ASTM A479 TY 316 with Hardfaced Seat (HRC 22 Max.)		
14	Seat Ring Gasket		316L St. St. w/Flexible Graphite Filler (Spiral Wound)		
15	Valve Plug		316 St. St. ASTM A479 TY 316 with Hardfaced Seat (HRC 22 Max.)		
16	Cage		Martensitic St. St. ASTM A487 GR CA6NM CL B Hard Chrome Plated		
18	Valve Body		Carbon Steel ASTM A216 Grade WCC (NRC 22 Max.)		
			316 St. St. ASTM A351 Gr CF8M (HRC 22 Max.)		
21	Valve Body Stud		Alloy Steel ASTM A193 GR B7 <sup>(2)</sup> Alloy Steel ASTM A 193 GRADE B7M		
22	Guide Bushing		316 St. St. ASTM A479 TY 316 with Hardfacing		
23	Packing Follower		316 St. St. ASTM A479 TY 316 (HRC 22 Max.)		
24	Cage Gasket <sup>(3)</sup>		316L St. St. w/Flexible Graphite Filler (Spiral Wound)		
28	Retaining Ring				ASTM A564 Gr 632 H950 St. St
29	Retaining Ring				316 St. St. ASTM A479 TY 316
37	Stack		Inconel 718 ASTM B637 Solution Annealed and Precipitation Hardened		

- Standard materials and processes are in accordance with the requirements of NACE specification MR0103. Applications requiring compliance to MR0175-2003 or ISO15156 must be reviewed by Baker Hughes.
- Materials designated for these parts conform to NACE Class III bolting requirements. (Non-Exposed).
- Materials designated for these parts conform to NACE Class I or Class II bolting requirements. (Exposed).

# Dimensions (inches)

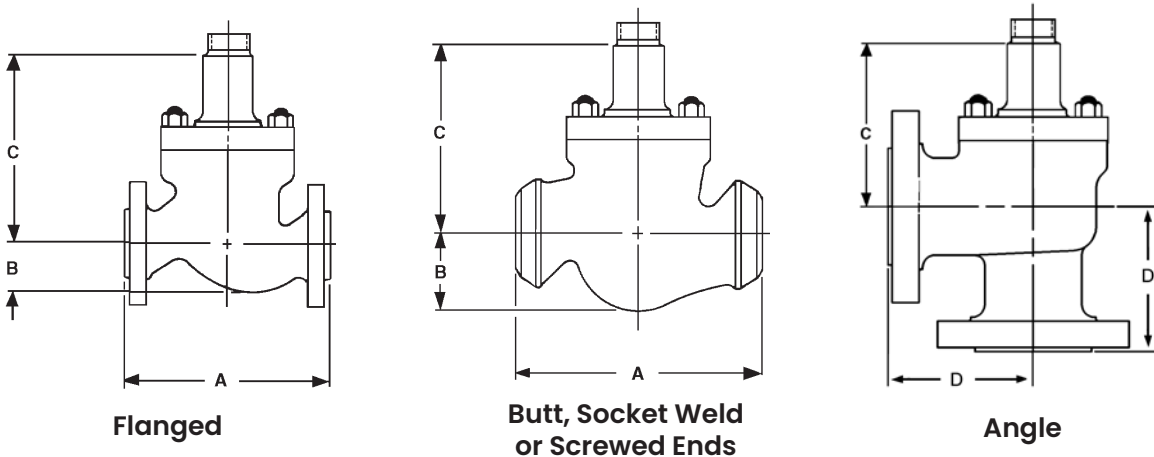

Pressure Class		A										
		ASME Class 150 and equivalent PN		ASME Class 300 and equivalent PN			ASME Class 600 and equivalent PN			ASME Class 900 and equivalent PN		
Valve Size		RF	RTJ	BW & SW	RF	RTJ	BW & SW	RF	RTJ	BW & SW	RF	RTJ
in.	mm											
2	50	10.00	10.50	11.26	10.50	11.12	11.26	11.24	11.38	14.76	14.74	14.88
3	80	11.75	12.25	13.27	12.50	13.12	13.27	13.25	13.37	18.11 <sup>(1)</sup>	17.38 <sup>(1)</sup>	17.48 <sup>(1)</sup>
4	100	13.86	14.33	15.51	14.50	15.12	15.51	15.50	15.62	20.87 <sup>(1)</sup>	20.12 <sup>(1)</sup>	20.24 <sup>(1)</sup>
6	150	17.75	18.27	20	18.64	19.25	20	20	20.12	30.24	28.12	28.24
6x3	150x80											
6x4	150x100											
8	200	21.38	21.87	24.02	22.38	22.99	24.02	24	24.13	32.76	36.00	36.00
8x4	200x100											
8x6	200x150											
10	250	26.50	27.00	29.61	27.88	28.50	29.61	29.62	29.72	39.02	43.00	43.12
10x6	250x150											
10x8	250x200											
12	300	29.02	29.53	32.24	30.51	31.14	32.24	32.25	32.36	44.49	44.49	44.61
12x8	300x200											
14	350	35	35.5	38.25	36.50	37.13	38.25	38.25	38.39	49.88	49.5	49.88
16	400	40.00	40.51	43.62	41.61	42.25	43.62 <sup>(1)</sup>	43.62	43.74	55.98 <sup>(1)</sup>	54.72 <sup>(1)</sup>	55.08 <sup>(1)</sup>
18	450	44.76	45.08	48.82	46.85	47.32	48.82 <sup>(3)</sup>	51.50	51.97	64.72	58.03	58.50
20	500	65.43	65.91	71.14	67.09	67.80	74.41	69.57	69.80	84.72	71.06	71.57
24	600	78.70	79.21	86.22	80.94	81.81	94.33	83.46	83.86	-	-	-
32x30	812.8	1090	-	-	1090	-	-	-	-	-	-	-

1. Consult Baker Hughes.
2. Ex. 3x2 size = valve with 3" body x standard 2" trim.
3. Applies to Schedule 40 only. Schedule 80 Face to Face is 58.27 in.

Note: Values for B and C are shown as maximum and may vary with valve body and bonnet attributes. Certified drawings will provide specific dimensions.

# Dimensions (inches)

Pressure Class		A			A			B max					C max				
		ASME Class 1500 and equivalent PN			ASME Class 2500 and equivalent PN			ASME 150 / 300	ASME 600	ASME 900	ASME 1500	ASME 2500	ASME 150 / 300	ASME 600	ASME 900	ASME 1500	ASME 2500
Valve Size		BW & SW	RF	RTJ	BW & SW	RF	RTJ										
in.	mm																
2	50	14.76	14.74	14.88	15.75	17.17	17.24	3.70	3.70	2.24	2.24	5.12	9.84	9.84	8.50	8.50	10.31
3	80	18.11	18.13	18.23	19.61	19.13	19.33	4.49	4.49	5.63	5.63	6.89	11.81	11.81	11.81	11.81	14.06
3x2	80x50 <sup>(2)</sup>	(i)	(i)	(i)	(i)	(i)	(i)	4.57	4.57	5.63	5.63	(i)	9.88	9.88	10.39	10.39	(i)
4	100	20.87	20.88	21.00	22.64	23.66	23.98	5.51	5.51	6.26	6.26	7.87	12.99	12.99	12.99	12.99	14.76
4x2	100x50	(i)	(i)	(i)	(i)	(i)	(i)	5.51	5.51	6.06	6.06	(i)	10.28	10.28	10.08	10.08	(i)
4x3	100x80	20.87	20.88	21.00	(i)	(i)	(i)	5.51	5.51	6.26	6.26	(i)	12.68	12.68	12.68	12.68	(i)
6	150	30.24	30.24	30.47	32.24	29.33	29.45	7.80	7.80	8.54	8.54	10.35	15.35	15.35	15.35	15.35	15.39
6x3	150x80	30.24	30.24	30.47	(i)	(i)	(i)	7.48	7.48	6.30	6.30	(i)	12.68	12.68	12.60	12.60	(i)
6x4	150x100	30.24	30.24	30.47	(i)	(i)	(i)	7.48	7.48	6.30	6.30	(i)	13.46	13.46	13.27	13.27	(i)
8	200	32.76	38.25	38.62	40.51	35.12	35.67	7.32	7.52	7.52	8.07	11.81	19.53	19.53	20.51	20.51	17.72
8x4	200x100	32.76	38.25	38.62	(i)	(i)	(i)	8.74	8.74	6.69	6.69	(i)	14.41	14.41	12.99	12.99	(i)
8x6	200x150	32.76	38.25	38.62	(i)	(i)	(i)	8.74	8.74	6.77	6.77	(i)	17.05	17.05	15.35	15.35	(i)
10	250	39.02	46.00	46.38	50.00	42.72	43.54	8.66	8.98	9.06	9.61	14.25	21.65	21.65	22.44	22.44	24.21
10x6	250x150				(i)	(i)	(i)	9.13	9.13	9.09	9.09	(i)	18.46	18.46	15.35	15.35	(i)
10x8	250x200				(i)	(i)	(i)	9.13	9.13	8.58	8.74	(i)	19.65	19.65	20.51	20.51	(i)
12	300	44.49	47.95	48.58	55.98	46.93	47.76	12.80	13.19	13.58	14.17	16.30	24.41	24.41	24.65	24.65	24.90
12x8	300x200	(i)	(i)	(i)	(i)	(i)	(i)	9.53	9.53	9.84	9.84	(i)	19.53	19.53	20.51	20.51	(i)
14	350	54.92	49.50	50.25	-	-	-	17.32	17.32	18.50	18.50	-	26.10	26.10	27.48	31.85	-
16	400	55.98	59.37	60.24	72.44	-	-	17.32	17.72	18.11	19.09	17.36	27.32	27.32	31.69	31.69	27.52
16x12	400x300	(i)	(i)	(i)	(i)	-	-	17.72	17.72	17.83	18.78	(i)	25.59	25.59	27.40	27.40	(i)
18	450	72.05	61.34	61.81	-	-	-	20.43	20.91	20.91	21.97	-	33.62	33.62	39.13	42.09	-
20	500	-	-	-	-	-	-	26.34	26.77	27.24	-	-	34.13	35.59	37.40	-	-
24 <sup>(3&amp;4)</sup>	600	-	-	-	-	-	-	31.65	32.28	-	-	-	40.00	41.18	-	-	-
								31.65	32.28				47.99	49.17			

1. Consult Baker Hughes.
2. Ex. 80x50 size = valve with 80mm body x standard 50mm trim.
3. 11" Nominal stroke length.
4. 15" Nominal stroke length.

Note: Values for B and C are shown as maximum and may vary with valve body and bonnet attributes. Certified drawings will provide specific dimensions.

# Dimensions (inches)

## Angle Body S/A (inches)

Pressure Class		D														
		ASME Class 150 and equivalent PN			ASME Class 300 and equivalent PN			ASME Class 600 and equivalent PN			ASME Class 900 and equivalent PN			ASME Class 1500 and equivalent PN		
Valve Size		BW	RF	RTJ	BW	RF	RTJ	BW	RF	RTJ	BW	RF	RTJ	BW	RF	RTJ
in.	mm															
2	50	7.44	5.15	5.38	7.44	5.27	5.58	7.44	5.78	5.84	8.66	7.27	7.35	8.66	7.27	7.35
3	80	7.5	5.92	6.17	7.5	6.29	6.61	7.5	7.04	7.12	9.27	8.89	8.97	9.27	9.28	9.36
4	100	7.9	7.71	7.94	9.2	8.04	8.34	9.29	8.53	8.61	10.5	10.38	10.46	-	10.78	10.86
6	150	8.07	8.34	8.59	8.07	8.77	9.09	11.2	11.02	11.07	16.3	12.04	12.10	16.3	13.89	14.01
8	203	14.7	13.2	-	14.4	13.2	-	14.7	14.0	14.0	17.0	-	-	16.2	16.2	16.3

## High Capacity Globe valve (inches)

Pressure Class		150		300			600				
Valve Size		Dimension	RF	RTJ	BW	RF	RTJ	BW	RF	RTJ	
in.	mm										
6	150	A	17.76	17.76	20.00	18.62	18.62	20.00	20.00	20.00	
		B	5.43	5.43	5.43	5.43	5.43	5.47	5.47	5.47	
		C (no ext.)	15.51	15.51	15.51	15.51	15.51	15.51	15.51	15.51	15.51
		C (w. ext.)	18.62	18.62	18.62	18.62	18.62	18.62	18.62	18.62	18.62
8	200	A	21.38	21.38	24.02	22.36	22.36	24.02	24.02	24.02	
		B	7.48	7.48	7.48	7.48	7.48	7.68	7.68	7.68	
		C (no ext.)	16.46	16.46	16.46	16.46	16.46	16.46	16.46	16.46	16.46
		C (w. ext.)	19.57	19.57	19.57	19.57	19.57	19.57	19.57	19.57	19.57
10	250	A	26.50	27.01	29.61	27.87	28.50	29.61	29.61	29.72	
		B	10.16	10.16	10.16	10.16	10.16	10.43	10.43	10.43	
		C	24.37	24.37	24.37	24.37	24.37	24.37	24.37	24.37	
12	300	A	29.02	29.49	32.24	30.51	31.10	32.24	32.24	32.36	
		B	10.98	10.98	10.98	10.98	10.98	11.50	11.50	11.50	
		C	31.26	31.26	31.26	31.26	31.26	31.61	31.61	31.61	
16	400	A	-	-	-	-	-	43.62	43.62	43.74	
		B	-	-	-	-	-	15.12	15.12	15.12	
		C	-	-	-	-	-	32.87	32.87	32.87	
18	450	A	44.76	45.08	48.82	46.85	47.32	48.82	51.50	51.97	
		B	15.35	15.35	15.35	15.35	15.35	16.89	16.89	16.89	
		C	33.78	33.78	33.78	33.78	33.78	33.78	33.78	33.78	
20	500	A	65.43	65.91	71.14	67.09	67.80	-	-	-	
		B	20.94	20.94	20.94	20.94	20.94	-	-	-	
		C	39.21	39.21	39.21	39.21	39.21	-	-	-	
24	600	A	78.82	79.33	86.34	81.06	81.93	-	-	-	
		B	22.85	22.95	22.95	22.95	22.95	-	-	-	
		C	45.91	45.91	45.91	45.91	45.91	-	-	-	



# Dimensions (mm)

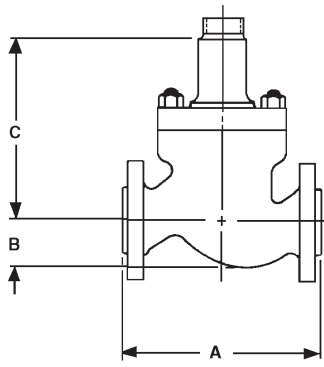

**Flanged**

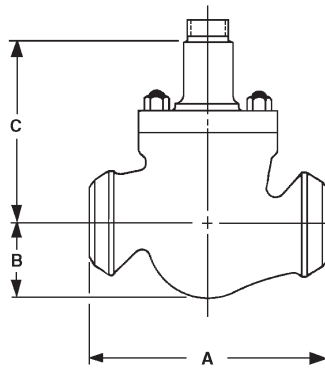

**Butt, Socket Weld  
or Screwed Ends**

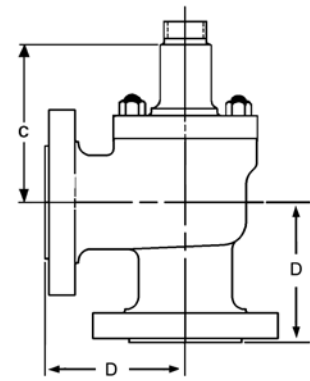

**Angle**

Pressure Class		A										
		ASME Class 150 and equivalent PN		ASME Class 300 and equivalent PN			ASME Class 600 and equivalent PN			ASME Class 900 and equivalent PN		
Valve Size		RF	RTJ	BW & SW	RF	RTJ	BW & SW	RF	RTJ	BW & SW	RF	RTJ
in.	mm											
2	50	254	266.5	286	266.5	282.5	286	285.5	289	375	374.5	378
3	80	298.5	311	337	317.5	333.5	337	336.5	339.5	460	441.5	444
3x2	80x50 <sup>(2)</sup>									(1)	(1)	(1)
4	100	352	364	394	368.5	384	394	393.5	397	530	511	514
4x2	100x50									(1)	(1)	(1)
4x3	100x80									530	511	514
6	150	451	464	508	473	489	508	508	511	768	714	717
6x3	150x80											
6x4	150x100											
8	200	543	555.5	610	568.5	584	610	609.5	613	832	914.5	917.5
8x4	200x100											
8x6	200x150											
10	250	673	686	752	708	724	752	752	755	991	1092	1095
10x6	250x150											
10x8	250x200											
12	300	737	750	819	775	791	819	819	822	1130	1130	1133
12x8	300x200											
14	350	889	902	972	927	943	972	972	975	1267	1257	1267
16	400	1016	1029	1108	1057	1073	1108	1108	1111	1422	1390	1399
16x12	400x300						(1)			(1)	(1)	
18	450	1137	1145	1240	1190	1202	1240 <sup>(3)</sup>	1308	1320	1644	1474	1486
20	500	1662	1674	1807	1704	1722	1890	1767	1773	2152	1805	1818
24	600	1999	2012	2190	2056	2078	2396	2120	2130	-	-	-
32x30	812.8	1090	-	-	1090	-	-	-	-	-	-	-

1. Consult Baker Hughes.
2. Ex. 80x50 size = valve with 80mm body x standard 50mm trim.
3. Applies to Schedule 40 only. Schedule 80 Face to Face is 1480 mm.

Note: Values for B and C are shown as maximum and may vary with valve body and bonnet attributes. Certified drawings will provide specific dimensions.

# Dimensions (mm)

Pressure Class		A			A			B max					C max				
		ASME Class 1500 and equivalent PN			ASME Class 2500 and equivalent PN			ASME 150 / 300	ASME 600	ASME 900	ASME 1500	ASME 2500	ASME 150 / 300	ASME 600	ASME 900	ASME 1500	ASME 2500
Valve Size		BW & SW	RF	RTJ	BW & SW	RF	RTJ										
in.	mm																
2	50	375	374.5	378	400	436	438	94	94	57	57	130	250	250	216	216	262
3	80	460	460.5	463	498	486	491	114	114	143	143	175	300	300	300	300	357
3x2	80x50 <sup>(2)</sup>	(1)	(1)	(1)	(1)	(1)	(1)	116	116	143	143	(1)	251	251	264	264	(1)
4	100	530	530.5	533.5	575	601	609	140	140	159	159	200	330	330	330	330	375
4x2	100x50	(1)	(1)	(1)	(1)	(1)	(1)	140	140	154	154	(1)	261	261	256	256	(1)
4x3	100x80	530	530.5	533.5	(1)	(1)	(1)	140	140	159	159	(1)	322	322	322	322	(1)
6	150	768	768	774	819	745	748	198	198	217	217	263	390	390	390	390	391
6x3	150x80	768	768	774	(1)	(1)	(1)	190	190	160	160	(1)	322	322	320	320	(1)
6x4	150x100	768	768	774	(1)	(1)	(1)	190	190	160	160	(1)	342	342	337	337	(1)
8	200	832	971.5	981	1029	892	906	186	191	191	205	300	496	496	521	521	450
8x4	200x100	832	971.5	981	(1)	(1)	(1)	222	222	170	170	(1)	366	366	330	330	(1)
8x6	200x150	832	971.5	981	(1)	(1)	(1)	222	222	172	172	(1)	433	433	390	390	(1)
10	250				1270	1085	1106	220	228	230	244	362	550	550	570	570	615
10x6	250x150	991	1168	1178	(1)	(1)	(1)	232	232	231	231	(1)	469	469	390	390	(1)
10x8	250x200				(1)	(1)	(1)	232	232	218	222	(1)	499	499	521	521	(1)
12	300	1130	1218	1234	1422	1192	1213	325	335	345	360	415	620	620	626	626	632
12x8	300x200	(1)	(1)	(1)	(1)	(1)	(1)	242	242	250	250	(1)	496	496	521	521	(1)
14	350	1395	1257	1276	-	-	-	440	440	470	470	-	663	663	698	809	-
16	400	1422	1508	1530	1840	-	-	440	450	460	485	441	694	694	805	805	699
16x12	400x300	(1)	(1)	(1)	(1)	-	-	450	450	453	477	(1)	650	650	696	696	(1)
18	450	1830	1558	1570	-	-	-	519	531	531	558	-	854	854	994	1069	-
20	500	-	-	-	-	-	-	669	680	692	-	-	867	904	950	-	-
24 <sup>(3)</sup>	600	-	-	-	-	-	-	804	820	-	-	-	1016	1046	-	-	-
24 <sup>(4)</sup>	600	-	-	-	-	-	-	804	820	-	-	-	1219	1249	-	-	-

1. Consult Baker Hughes.
2. Ex. 80x50 size = valve with 80mm body x standard 50mm trim.
3. 11" Nominal stroke length.
4. 15" Nominal stroke length.

Note: Values for B and C are shown as maximum and may vary with valve body and bonnet attributes. Certified drawings will provide specific dimensions.

## Applicable Size Ranges

PN	ASME Construction Equivalency (other than Body (B001))
EN PN 10	ASME Class 150
EN PN 16	ASME Class 150
EN PN 25	ASME Class 300
EN PN 40	ASME Class 300
EN PN 63	ASME Class 600

## B1 Flanges Face-to-Face Dimensions mm

Rating \ DN	PN 10-PN 16	PN 25-PN 40	PN 63
2	254 ± 1.5	266.5 ± 1.5	285.5 ± 1.5
3	298.5 ± 1.5	317.5 ± 1.5	336.5 ± 1.5
4	352 ± 1.5	368.5 ± 1.5	393.5 ± 1.5
6	451 ± 1.5	473 ± 1.5	508 ± 1.5
8	543 ± 1.5	568.5 ± 1.5	609.5 ± 1.5

# Dimensions (mm)

## High Capacity Globe valve (mm)

Pressure Class		150			300			600		
Valve Size		Dimension	RF	RTJ	BW	RF	RTJ	BW	RF	RTJ
in.	mm									
6	150	A	451	451	508	473	473	508	508	508
		B	138	138	138	138	138	139	139	139
		C (no ext.)	394	394	394	394	394	394	394	394
		C (w. ext.)	473	473	473	473	473	473	473	473
8	200	A	543	543	610	568	568	610	610	610
		B	190	190	190	190	190	195	195	195
		C (no ext.)	418	418	418	418	418	418	418	418
		C (w. ext.)	497	497	497	497	497	497	497	497
10	250	A	673	686	752	708	724	752	752	755
		B	258	258	258	258	258	265	265	265
		C	619	619	619	619	619	619	619	619
12	300	A	737	749	819	775	790	819	819	822
		B	279	279	279	279	279	292	292	292
		C	794	794	794	794	794	803	803	803
16	400	A	-	-	-	-	-	1108	1108	1111
		B	-	-	-	-	-	384	384	384
		C	-	-	-	-	-	835	835	835
18	450	A	1137	1145	1240	1190	1202	1240	1308	1320
		B	390	390	390	390	390	429	429	429
		C	858	858	858	858	858	858	858	858
20	500	A	1662	1674	1807	1704	1722	-	-	-
		B	532	532	532	532	532	-	-	-
		C	996	996	996	996	996	-	-	-
24	600	A	2002	2015	2193	2059	2081	-	-	-
		B	583	583	583	583	583	-	-	-
		C	1166	1166	1166	1166	1166	-	-	-

## Angle Body S/A (mm)

Pressure Class	D															
	ASME Class 150 and equivalent PN			ASME Class 300 and equivalent PN			ASME Class 600 and equivalent PN			ASME Class 900 and equivalent PN			ASME Class 1500 and equivalent PN			
Valve Size		BW	RF	RTJ	BW	RF	RTJ	BW	RF	RTJ	BW	RF	RTJ	BW	RF	RTJ
in.	mm															
2	50	189	131	137	189	134	142	189	147	148	220	185	187	220	185	187
3	80	191	150	157	191	160	168	191	179	181	235.5	226	228	235.5	236	238
4	100	201	196	202	236	204	212	236	217	219	266.7	264	266	-	274	276
6	150	205	212	218	205	223	231	285	280	281	415	306	307	415	353	356
8	203	374	337	-	374	337	-	374	358	358	434	-	-	412	412	416

# Weights

## Globe Style Body S/A Weights (lbs)

Valve Size		Flanged Connection						Threaded / Welded Connection					
in.	mm	ASME Class 150 & equivalent PN	ASME Class 300 & equivalent PN	ASME Class 600 & equivalent PN	ASME Class 900 & equivalent PN	ASME Class 1500 & equivalent PN	ASME Class 2500 & equivalent PN	ASME Class 150 & equivalent PN	ASME Class 300 & equivalent PN	ASME Class 600 & equivalent PN	ASME Class 900 & equivalent PN	ASME Class 1500 & equivalent PN	ASME Class 2500 & equivalent PN
2	50	99	99	88	121	121	320	88	88	88	88	88	(1)
3	80	176	187	187	265	287	518	165	165	165	220	220	(1)
3x2	80x50	143	154	165	198	220	(1)	132	132	132	154	154	(1)
4	100	231	254	265	463	496	860	209	209	209	386	397	(1)
4x2	100x50	176	198	209	331	364	(1)	154	154	154	254	265	(1)
4x3	100x80	209	220	243	397	430	(1)	176	187	187	331	331	(1)
6	150	397	430	518	893	1036	1653	363	363	408	750	816	(1)
6x3	150x80	320	364	441	739	893	(1)	286	297	342	595	661	(1)
6x4	150x100	353	386	474	805	948	(1)	319	319	364	650	717	(1)
8	200	772	827	937	1400	1698	2679	727	738	783	1146	1323	(1)
8x4	200x100	584	639	750	1157	1466	(1)	529	540	584	915	1091	(1)
8x6	200x150	628	683	794	1257	1554	(1)	573	584	628	1003	1179	(1)
10	250	1168	1257	1378	2227	2646	4806	1102	1113	1124	1863	2006	(1)
10x6	250x150	838	926	1047	1775	2194	(1)	771	782	794	1422	1554	(1)
12	300	1532	1631	2116	2932	4288	7176	1421	1444	1819	2458	3329	(1)
12x8	300x200	1135	1235	1720	2502	3671	(1)	1036	1047	1422	2028	2723	(1)
14	350	1951	2129	2698	4576	6867	-	1893	1893	2336	4096	5782	-
16	400	3274	3472	3847	6338	7959	-	3119	3152	3318	5666	6294	(1)
16x12	400x300	3009	3197	3395	5776	7363	-	2843	2888	2877	5093	5699	(1)
18	450	3583	3869	5192	8267	12765	-	3163	3163	4652	7507	11023	-
20	500	6989	7363	9160	11729	-	-	6790	6790	8311	11442	-	-
24 <sup>(1)</sup>	600 <sup>(1)</sup>	10659	11431	13702	-	-	-	10813	10813	13062	-	-	-
30	762	18287	20172	28219	-	-	-	-	-	-	-	-	-
32x30	812x762	18739	20943	-	-	-	-	-	-	-	-	-	-

1. Consult Baker Hughes.

Note: Weight values are maximum and may vary with valve body and bonnet attributes. Certified drawings will provide specific values.

## Globe Style Body S/A Weights (kg)

Valve Size		Flanged Connection						Threaded / Welded Connection					
in.	mm	ASME Class 150 & equivalent PN	ASME Class 300 & equivalent PN	ASME Class 600 & equivalent PN	ASME Class 900 & equivalent PN	ASME Class 1500 & equivalent PN	ASME Class 2500 & equivalent PN	ASME Class 150 & equivalent PN	ASME Class 300 & equivalent PN	ASME Class 600 & equivalent PN	ASME Class 900 & equivalent PN	ASME Class 1500 & equivalent PN	ASME Class 2500 & equivalent PN
2	50	45	45	40	55	55	145	40	40	40	40	40	(1)
3	80	80	85	85	120	130	235	75	75	75	100	100	(1)
3x2	80x50	65	70	75	90	100	(1)	60	60	60	70	70	(1)
4	100	105	115	120	210	225	390	95	95	95	175	180	(1)
4x2	100x50	80	90	95	150	165	(1)	70	70	70	115	120	(1)
4x3	100x80	95	100	110	180	195	(1)	80	85	85	150	150	(1)
6	150	180	195	235	405	470	750	165	165	185	340	370	(1)
6x3	150x80	145	165	200	335	405	(1)	130	297	155	270	300	(1)
6x4	150x100	160	175	215	365	430	(1)	145	145	165	295	325	(1)
8	200	350	375	425	635	770	1215	330	335	355	520	600	(1)
8x4	200x100	265	290	340	525	665	(1)	240	245	265	415	495	(1)
8x6	200x150	285	310	360	570	705	(1)	260	265	285	455	535	(1)
10	250	530	570	625	1010	1200	2180	500	505	510	845	910	(1)
10x6	250x150	380	420	475	805	995	(1)	350	355	360	645	705	(1)
12	300	695	740	960	1330	1945	3255	645	655	825	1115	1510	(1)
12x8	300x200	515	560	780	1135	1665	(1)	470	475	645	920	1235	(1)
14	350	885	966	1224	2076	3115	-	859	859	1060	1858	2623	-
16	400	1485	1575	1745	2875	3610	-	1415	1430	1505	2570	2855	(1)
16x12	400x300	1365	1450	1540	2620	3340	-	1290	1310	1305	2310	2585	(1)
18	450	1625	1755	2355	3750	5790	-	1435	1435	2110	3405	5000	-
20	500	3170	3340	4155	5320	-	-	3080	3080	3770	5190	-	-
24 <sup>(1)</sup>	600 <sup>(1)</sup>	4835	5185	6215	-	-	-	4905	4905	5925	-	-	-
30	762	8295	9150	12800	-	-	-	-	-	-	-	-	-
32x30	812x762	8500	9500	-	-	-	-	-	-	-	-	-	-

1. Consult Baker Hughes.

Note: Weight values are maximum and may vary with valve body and bonnet attributes. Certified drawings will provide specific values.

# Weights

## Globe Style Body S/A High Capacity Trim Weights (lbs)

Valve Size		Flanged Connection			Welded Connection	
Inches	mm	ASME Class 150	ASME Class 300	ASME Class 600	ASME Class 300	ASME Class 600
6	150	390	390	507	333	575
8	200	664	664	935	576	774
10	250	1155	1230	1786	1096	1552
12	300	1768	1881	2269	1826	2134
16	400	3305	3495	4807	3151	4322
18	450	4937	5228	8824	4847	8401
20	500	7651	8017	-	7632	-
24	600	12238	12789	-	12436	-

## Globe Style Body S/A High Capacity Trim Weights (kg)

Valve Size		Flanged Connection			Welded Connection	
Inches	mm	ASME Class 150	ASME Class 300	ASME Class 600	ASME Class 300	ASME Class 600
6	150	177	177	230	151	270
8	200	301	301	424	261	351
10	250	524	558	810	497	704
12	300	802	853	1029	828	968
16	400	1499	1585	2180	1429	1960
18	450	2239	2371	4002	2198	3810
20	500	3470	3636	-	3461	-
24	600	5550	5800	-	5640	-

# Weights

## Angle Style Body S/A Weights (lbs)

Valve Size		Flanged Connection				
		ASME Class 150 and equivalent PN	ASME Class 300 and equivalent PN	ASME Class 600 and equivalent PN	ASME Class 900 and equivalent PN	ASME Class 1500 and equivalent PN
in.	mm					
2	50	77	79	82	110	110
3	80	154	165	165	231	254
4	100	209	220	243	419	463
6	150	353	375	452	838	992

## Angle Style Body S/A Weights (kg)

Valve Size		Flanged Connection				
		ASME Class 150 and equivalent PN	ASME Class 300 and equivalent PN	ASME Class 600 and equivalent PN	ASME Class 900 and equivalent PN	ASME Class 1500 and equivalent PN
in.	mm					
2	50	35	36	37	50	50
3	80	70	75	75	105	115
4	100	95	100	110	190	210
6	150	160	170	205	380	450

## Options

- Extension Bonnets
- Environmental Capabilities (Low-E Packing)
- Lubricator & Isolation Valve
- Other Flange Facings
- Limit Stops
- Body Drain Plug
- Reducer and Nipple Connections
- NACE Compliance
- Custom Trim Materials
- U.O.P. Trim Materials
- Other Materials
- Soft Seat (IEC 534-4 and ASME Class VI)
- Non-Destructive Examination
- Oxygen Cleaning
- Anti-Surge Applications

**For Accessories and additional Options, please consult Baker Hughes.**



# 41005 API-6A Series High Pressure Valves

## Features

41005 API 6A Series single ported, cage guided control valves are designed to meet API 6A standard for high pressure applications:

### Forged Body

Globe Forged body handles pressure up to 15K PSI in operation.

### Body/Bonnet Bolted Joint

API 6A 41005 uses body bonnet bolting joint and metal seal for high pressures up to 15K PSI in operation.

### Body/Bonnet Metallic Seal

41005 API 6A seal is a low leakage design using a metallic seal.

### Integral Cage Seat-Ring Trim

41005 API 6A trim design is comprised of an Integral Seat-ring/Cage for easy maintenance. Available in linear flow characteristic it is also available with options for a ported cage, single stage Lo-dB and Double stage Lo-dB.

### High Pressure Capability

41005 API 6A valves meet API standards and are capable of 10K PSI [690 bar] and 15K PSI [1034 bar] rated pressure.

Cage Mechanical Pressure drop is limited as follows:

- 7252 PSI [500 bar] for double cage
- 4351 PSI [300 bar] for single stage Lo-dB
- 870 PSI [60 bar] for ported cage.

### Leakage Class

Meets class IV and V leakage is standard as per IEC-60534-4.

41005 API 6A should be closed only for a short period of time. There is a risk of damaging trim parts for a long period of closing.

41005 API 6A valves are designed as control valves, not as isolating valves.

### Hardened Trim

Provided to handle erosion from high pressure drop applications.

### Quick Change Trim

An integral seat-ring/cage design allows for quick disassembly for ease of maintenance.

### Packing

#### Standard

The Integral Packing flange/follower design improves flange stiffness for better performance against leaks.

#### Environmental

Low emission **LE™** Packing is available (consult factory for the latest certificate).

### NACE Compliance

The 41005 API 6A Series is available for Sour Service Applications using design and construction methods in accordance with ANSI/NACE MR0175/ISO 15156-1.

### Lifting lugs on body sub assembly

Lifting lugs are provided for easy handling.



# 41005 API 6A Numbering System

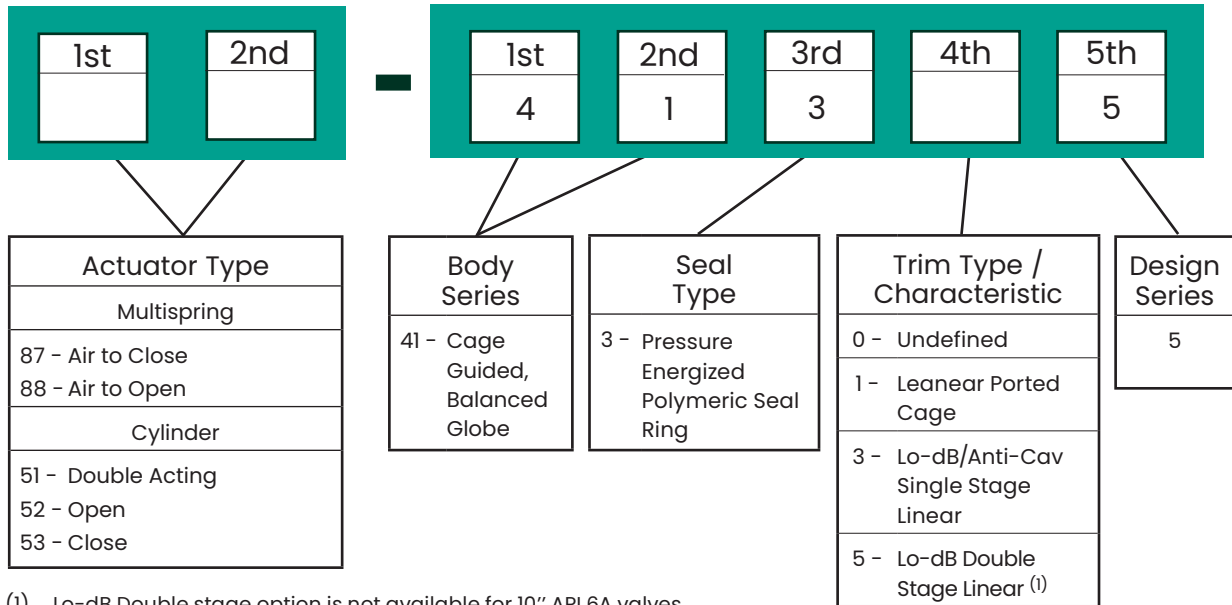

## Temperature Ratings

Temperature Class	Temperature Range <sup>(1)(2)</sup>			
	°C		°F	
	Min.	Max.	Min.	Max.
<b>K</b>	-60	82	-75	180
<b>L</b>	-46	82	-50	180
<b>N</b>	-46	60	-50	140
<b>P</b>	-29	82	-20	180
<b>S</b>	-18	60	0	140
<b>T</b>	-18	82	0	180
<b>U</b>	-18	121	0	250
<b>V</b>	2	121	35	250
<b>X</b>	-18	180	0	350

1. Valve end size fit API 6A standard for 6BX flanges and cover the entire product
2. See Materials of Construction Tables for other temperature limitations.

## Material Class/Material of Construction

Material Class		NACE MR0175/ISO 15156	Material of Construction Availability			
			Martensitic NACE Non-Exposed	Duplex NACE Non-Exposed	Super Duplex NACE Non-Exposed	Inconel 718 NACE Non-Exposed
AA	General Service	Non-Exposed	X	X	X	X
BB	General Service	Non-Exposed	X	X	X	X
CC	General Service	Non-Exposed	X	X	X	X
Material Class		NACE MR0175/ISO 15156	Material of Construction Availability			
			Martensitic NACE Exposed	Duplex NACE Exposed	Super Duplex NACE Exposed	Inconel 718 NACE Exposed
DD	Sour Service	Exposed				X
EE	Sour Service	Exposed				X
FF	Sour Service	Exposed	X	X	X	X
HH	Sour Service	Exposed				X

## Ratings/End Connections

Valve ends connection are designed to API 6A standard.

Valve Body Size	Valve Ends Size	API 10K	API 15K
NPS	NPS	6BX <sup>(1)</sup>	6BX <sup>(1)</sup>
3	4 <sup>1</sup> / <sub>16</sub> (4.0625)	X	X
4	5 <sup>1</sup> / <sub>8</sub> (5.125)	X	X
6	7 <sup>1</sup> / <sub>16</sub> (7.0625)	X	X
8	9"	X	X
10	11"	X	X

1. Only 6BX printed flange are available

## C<sub>V</sub> and F<sub>L</sub> Versus Travel

API 10K & 15K – Linear – Models 41315

Sizes: 3" through 10" Linear Ported Cage API 10K & 15K – Flow to Open/Flow to Close

Travel (Percent)						10	20	30	40	50	60	70	80	90	100
FL						0.94	0.94	0.93	0.93	0.92	0.92	0.91	0.91	0.9	0.9
Valve Body Size (NPS)		Orifice Dia.		Travel		Rated C <sub>V</sub>									
inch	mm	inch	mm	inch	mm										
3	80	3.5	88.9	2	50.8	2	12	25	45	64	83	109	127	143	155
4	100	4.38	111.13	2	50.8	4	17	38	72	106	138	171	188	204	214
6	150	5.12	130.04	2.5	63.5	14	70	127	186	236	287	331	356	377	400
8	200	6.5	165.1	3	76.2	28	121	209	295	372	452	539	576	624	640
10	250	8	203.2	3.5	88.90	67	210	353	494	629	752	852	913	972	1000

# C<sub>v</sub> and F<sub>L</sub> Versus Travel

## API 10K & 15K – Linear – Models 41335

Sizes: 3" through 10" Linear Lo-dB Single Stage API 10K & 15K – Flow to Open/Flow to Close

Travel (Percent)						10	20	30	40	50	60	70	80	90	100	
FL						0.94	0.94	0.94	0.94	0.94	0.94	0.94	0.94	0.94	0.94	0.94
Valve Body Size (NPS)		Orifice Dia.		Travel		Rated C <sub>v</sub>										
Inch	mm	inch	mm	inch	mm	Cv	3	12	22	31	40	48	57	65	72	78
3	80	3.5	88.9	2	50.8	Cv	3	12	22	31	40	48	57	65	72	78
4	100	4.38	111.25	2	50.8	Cv	7	24	42	59	76	89	101	114	127	140
6	150	5.12	130.04	2.5	63.5	Cv	9	37	65	88	118	136	159	183	207	230
8	200	6.5	165.1	2.5	63.5	Cv	7	48	87	127	166	201	235	270	304	340
10	250	8	203.2	3.5	88.90	Cv	24	81	136	193	249	297	346	394	443	500

## API 10K & 15K – Linear – Models 41355

Sizes: 3" through 8" Linear Lo-dB double Stage API 10K & 15K – Flow to Open Only (1)(2)

Travel (Percent)						10	20	30	40	50	60	70	80	90	100	
FL						0.95	0.95	0.95	0.95	0.95	0.95	0.95	0.95	0.95	0.95	0.95
Valve Body Size (NPS)		Orifice Dia.		Travel		Rated C <sub>v</sub>										
Inch	mm	inch	mm	inch	mm	Cv	2	7	12	17	22	27	31	35	40	42
3	80	3.5	88.9	2	50.8	2	7	12	17	22	27	31	35	40	42	
4	100	4.38	111.13	2	50.8	3	11	19	26	34	40	47	54	60	66	
6	150	5.12	130.04	2.5	63.50	3	14	24	33	44	52	61	70	79	90	
8	200	6.5	165.1	2.5	63.50	8	24	39	55	70	84	97	111	124	140	

1. Important : the Lo-dB double cage TRIMs are only low noise TRIM for gas.
2. Linear Lo-dB double stage is out of standard scope for 10" valves.

# Body Sub Assembly Construction

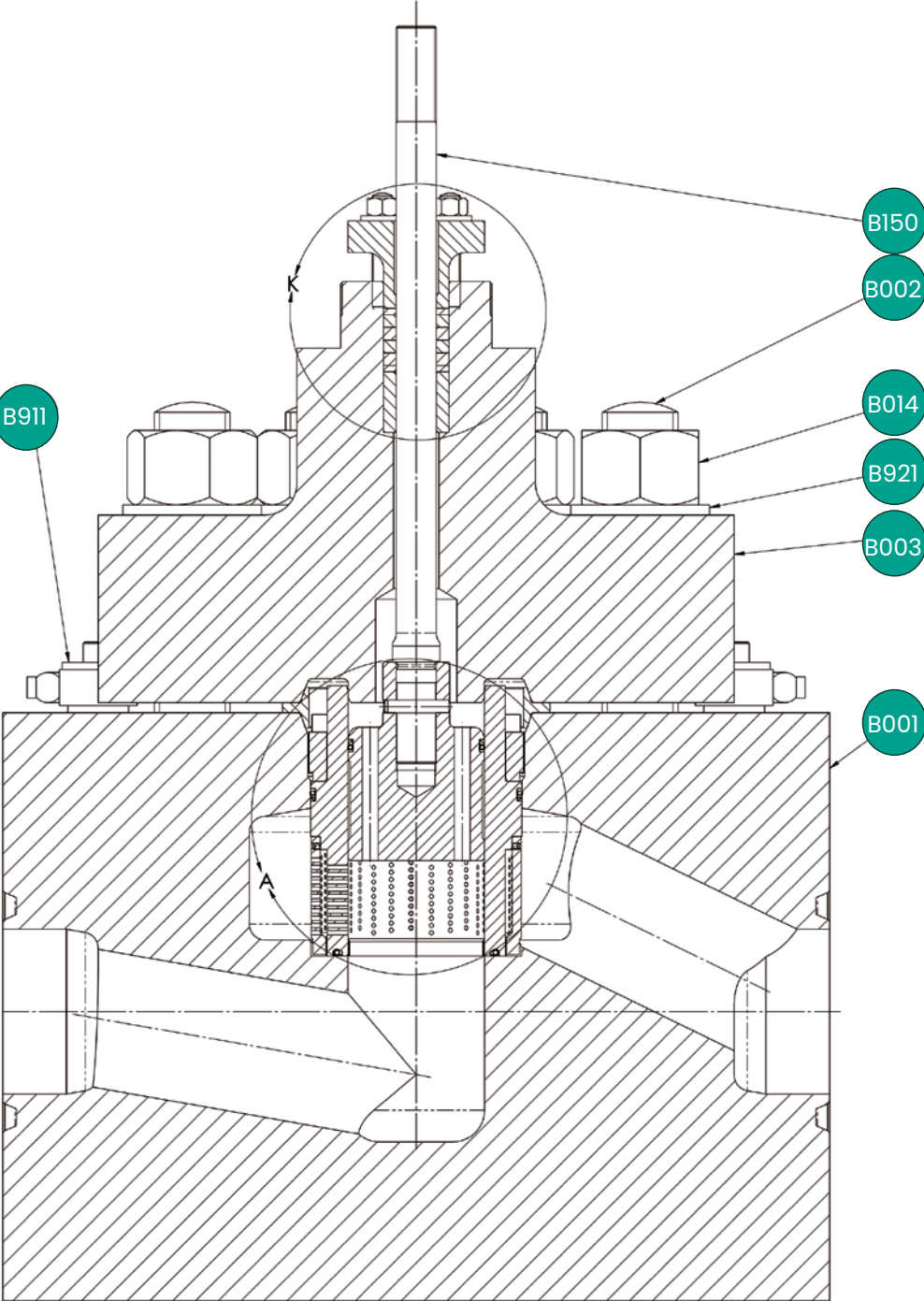
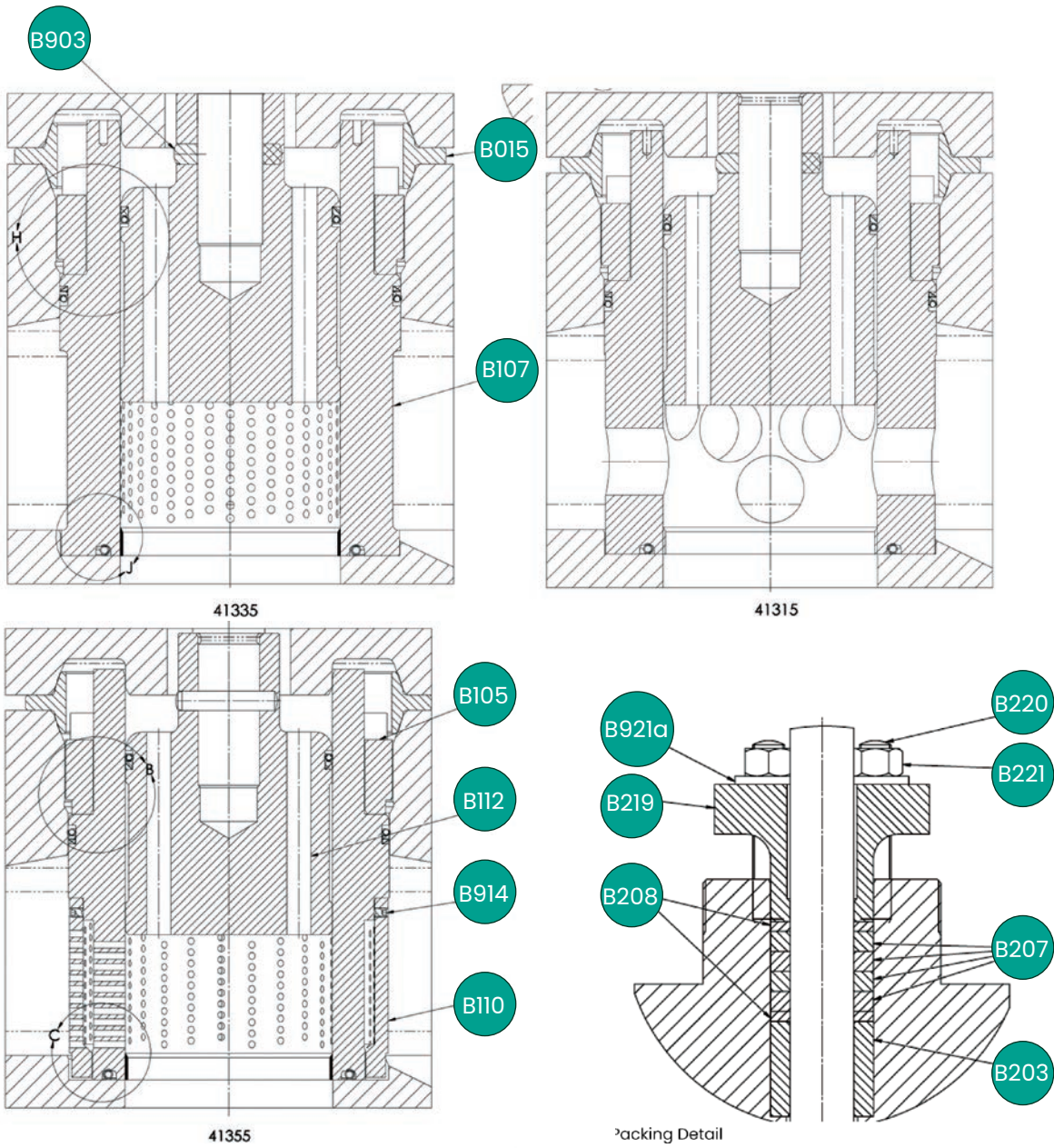
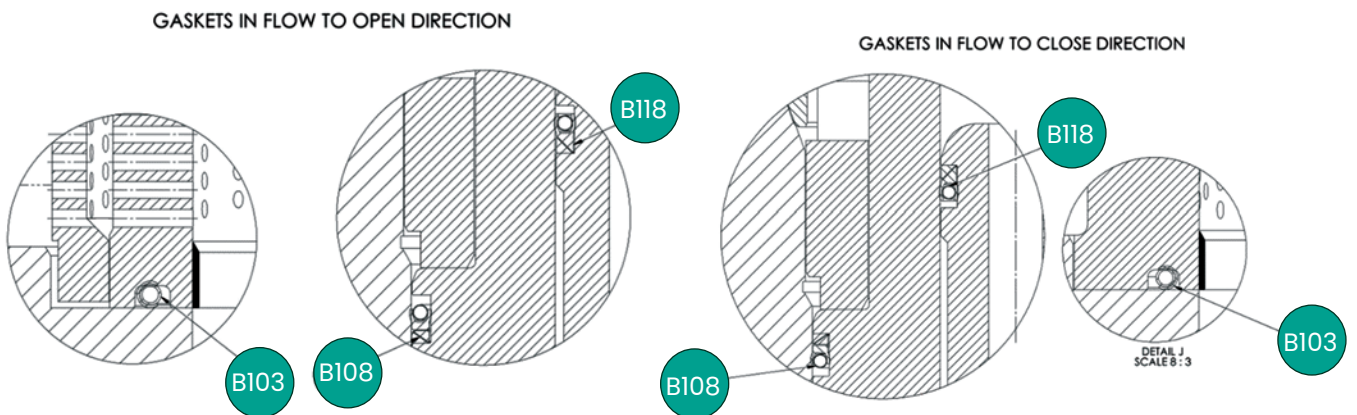

Figure x - Cross Sectional View of 41005 API 6A Design



**Figure x - Trim Type and Packing Detail**



**Figure x - Trim Gaskets Detail**

# Materials of Construction

## Martensitic Stainless Steel Construction

41005 API 6A Martensitic Stainless Steel construction is covering:

- Max operating pressure up to 15 kPSI [1034 bar]
- Temperature Ratings: K/L/N/P/S/T/U/V/X (Refer to table on page 41)
- Material classes: AA/BB/CC/FF (Refer to table on page 41)

Ref. No	Temperature Range	-60°C [-76°F]	-29°C [-20°F]	121°C [250°F]	180°C [356°F]	
		Materials				
B001	Valve Body	ASTM A182 GR F6NM API6A				
		ASTM A182 GR F6NM API6A ELEVATED TEMPERATURE X (see page 41)				
B002	Body Stud <sup>(4)</sup>		ASTM A193 GRADE B7 ZINC PLATED + PTFE COATING API6A <sup>(1&amp;5)</sup>			
			ASTM A193 GR B7M ELECTROLESS NICKEL PLATING + PTFE COATING <sup>(2&amp;5)</sup>			
			ASTM A320 Gr L7 ZINC PLATED + PTFE COATING <sup>(1&amp;5)</sup>			
			ASTM A320 Gr L7M ELECTROLESS NICKEL PLATING + PTFE COATING <sup>(2)</sup>			
B003	Bonnet	ASTM A182 GR F6NM API6A				
		ASTM A182 GR F6NM API6A ELEVATED TEMPERATURE X (see page 41)				
B014	Body Nut <sup>(4)</sup>		ASTM A194 GR 2H ZINC PLATED + PTFE COATING <sup>(1&amp;5)</sup>			
			ASTM A194 GR 2HM, ELECTROLESS NICKEL PLATING + PTFE COATING <sup>(2&amp;5)</sup>			
			ASTM A194 Gr 7 ZINC PLATED as per CES 1041 + PTFE COATING <sup>(1&amp;5)</sup>			
			ASTM A194 Gr 7M ELECTROLESS NICKEL PLATING + PTFE COATING <sup>(2&amp;5)</sup>			
B015	Body Gasket	ALLOY 718 + MOS2 COATING				
B103	Seat Ring Gasket	INCONEL 718 + SILVER PLATING				
B105	Retainer	SUPER AUSTENITIC STAINLESS STEEL UNS S20910 (NITRONIC X) 35 HRC MAXIMUM				
B107	Cage	ASTM A182 GR F6NM CL B + CHROME PLATING + STELLITE N°6 HARDFACING				
B108	Cage Gasket	PRESSURE ENERGIZED POLYMERIC				
B112	Plug	HARDFACING STELLITE 6 ON 6NM				
B110	Outer Cage	CA6NM CLASS B STAINLESS STEEL HB 255 MAXIMUM				
B118	Plug Balanced Seal	PRESSURE ENERGIZED POLYMERIC				

## 41005 API 6A Martensitic Stainless Steel construction (Cont.)

Ref. No	Temperature Range	-60°C [-76°F]	-29°C [-20°F]	121°C [250°F]	180°C [356°F]
		Materials			
B150	Plug Stem <sup>(3)</sup>	ASTM A182 GR F6NM API6A			
		ASTM A182 GR F6NM API6A ELEVATED TEMPERATURE X (see page 41)			
B203	Packing Bushing	STELLITE NO.6 OR EQUIVALENT			
B207	Packing Ring	CARBON CORE <sup>(6)</sup>			
B208	Anti Extrusion Ring	CARBON-GRAPHITE BRAIDED <sup>(6)</sup>			
B219	Packing Flange/ Follower <sup>(3)</sup>	ASTM A182 GR F6NM API6A			
		ASTM A182 GR F6NM API6A ELEVATED TEMPERATURE X (see page 41)			
B220	Packing Stud <sup>(4)</sup>		ASTM A193 GRADE B7 ZINC PLATED <sup>(1)</sup>		
			ASTM A193 GR B7M ELECTROLESS NICKEL PLATING <sup>(2)</sup>		
			ASTM A320 Gr L7 ZINC PLATED <sup>(1)</sup>		
			ASTM A320 Gr L7M ELECTROLESS NICKEL PLATING <sup>(2)</sup>		
B221	Packing Nut <sup>(4)</sup>		ASTM A 194 GR 2H ZINC PLATED <sup>(1)</sup>		
			ASTM A194 GR 2HM, ELECTROLESS NICKEL PLATING <sup>(2)</sup>		
			ASTM A194 GR 7 ZINC PLATED <sup>(1)</sup>		
			ASTM A194 GR 7M ELECTROLESS NICKEL PLATING <sup>(2)</sup>		
B903	Plug Pin	SOLUTION ANNEALED 316 STAINLESS STEEL HRC 22 MAXIMUM			
B914	Cage Set Screw	SOLUTION ANNEALED 316L HRC 22 MAXIMUM STAINLESS STEEL HARDNESS COMPLIANCE WITH NACE MR0103 & MR0175 SHALL BE CERTIFIED			
B921	Body plain Washer <sup>(4)</sup>	ASTM F436 ZINC PLATED			
		410 ST ST HRC 35-45			
B921a	Packing Plain Washer <sup>(4)</sup>	ASTM F436 ZINC PLATED			
		410 ST ST HRC 35-45			

Notes:

1. For General Service only: NACE Non-Exposed per ANSI/NACE MR0175/ISO 15156-1.
2. For Sour Service only: NACE Exposed per ANSI/NACE MR0175/ISO 15156-1.
3. Considered as pressure containing parts in API 6A specification see Design Practice BHDP10046.
4. Zinc electroplating is not permitted for splash zone or subsea service.
5. Blue is the standard coating color.
6. No equivalents allowed to maintain fugitive emission certification and performance.

# Materials of Construction

## Duplex F51 Stainless Steel Construction

41005 API 6A Duplex F51 Stainless-Steel construction is covering:

- Max operating pressure up to 10 kPSI [690 bar]
- Temperature class: L/N/P/S/T/U/V/X (Refer to table on page 41)
- Material class: AA/BB/CC/FF (Refer to table on page 41)

Ref. No.	Temperature Range	-46°C [-50°F]	-29°C [-20.2°F]	121°C [250°F]	180°C [356°F]
		Materials			
B001	Valve Body	ASTM A182 GR F51 API6A			
		ASTM A182 GR F51 API6A ELEVATED TEMPERATURE X (see page 41)			
B002	Body Stud <sup>(4)</sup>		ASTM A193 GRADE B7 ZINC PLATED + PTFE COATING API6A <sup>(1&amp;5)</sup>		
			ASTM A193 GR B7M ELECTROLESS NICKEL PLATING + PTFE COATING <sup>(2&amp;5)</sup>		
			ASTM A320 Gr L7 ZINC PLATED + PTFE COATING <sup>(1&amp;5)</sup>		
			ASTM A320 Gr L7M ELECTROLESS NICKEL PLATING + PTFE COATING <sup>(2&amp;5)</sup>		
B003	Bonnet	ASTM A182 GR F51 API6A			
		ASTM A182 GR F51 API6A ELEVATED TEMPERATURE X (see page 41)			
B014	Body Nut <sup>(4)</sup>		ASTM A 194 GR 2H ZINC PLATED + PTFE COATING <sup>(1&amp;5)</sup>		
			ASTM A194 GR 2HM, ELECTROLESS NICKEL PLATING + PTFE COATING <sup>(2&amp;5)</sup>		
			ASTM A194 Gr 7 ZINC PLATED + PTFE COATING <sup>(1&amp;5)</sup>		
			ASTM A194 Gr 7M ELECTROLESS NICKEL PLATING + PTFE COATING <sup>(2&amp;5)</sup>		
B015	Body Gasket	ALLOY 718 + MOS2 COATING			
B103	Seat Ring Gasket	INCONEL 718 + SILVER PLATING			
B105	Retainer	SUPER AUSTENITIC STAINLESS STEEL UNS S20910 (NITRONIC 50) 35 HRC MAXIMUM			
B107	Cage	ASTM A 479 UNS S31803 + STELLITE N°6 + CHROME PLATING			
B108	Cage Gasket	PRESSURE ENERGIZED POLYMERIC			
B110	Outer Cage	SOLUTION ANNEALED 2205 STAINLESS STEEL (DUPLEX) HRc 28 MAXIMUM			
B112	Plug	2205 STAINLESS STEEL (DUPLEX) HRc 28 MAXIMUM + HARDFACING STELLITE NO.6			
B118	Plug Balanced Seal	PRESSURE ENERGIZED POLYMERIC			



## Duplex F51 Stainless Steel construction (Cont.)

Ref. No.	Temperature Range	-46°C [-50°F]	-29°C [-20.2°F]	121°C [250°F]	180°C [356°F]	
		Materials				
B150	Plug Stem <sup>(3)</sup>	ASTM A182 GR F51 API6A				
		ASTM A182 GR F51 API6A ELEVATED TEMPERATURE X (see page 41)				
B203	Packing Bushing	STELLITE NO.6 OR EQUIVALENT				
B207	Packing Ring	CARBON CORE PTFE <sup>(6)</sup>				
B208	Anti Extrusion Ring	CARBON-GRAPHITE BRAIDED <sup>(6)</sup>				
B219	Packing Flange/ Follower <sup>(3)</sup>	ASTM A182 GR F51 API6A				
		ASTM A182 GR F51 API6A ELEVATED TEMPERATURE X (see page 41)				
B220	Packing Stud <sup>(4)</sup>				ASTM A193 GRADE B7 ZINC PLATED <sup>(1)</sup>	
					ASTM A193 GR B7M ELECTROLESS NICKEL PLATING <sup>(2)</sup>	
					ASTM A320 Gr L7 ZINC PLATED <sup>(1)</sup>	
					ASTM A320 Gr L7M ELECTROLESS NICKEL PLATING <sup>(2)</sup>	
B221	Packing Nut <sup>(4)</sup>				ASTM A 194 GR 2H ZINC PLATED <sup>(1)</sup>	
					ASTM A194 GR 2HM, ELECTROLESS NICKEL PLATING <sup>(2)</sup>	
					ASTM A194 GR 7 ZINC PLATED <sup>(1)</sup>	
					ASTM A194 GR 7M ELECTROLESS NICKEL PLATING <sup>(2)</sup>	
B903	Plug Pin	SOLUTION ANNEALED 2205 STAINLESS STEEL (DUPLEX) HRC 28 MAXIMUM				
B914	Cage Set Screw	SOLUTION ANNEALED 316L HRC 22 MAXIMUM STAINLESS STEEL HARDNESS COMPLIANCE WITH NACE MR0103 & MR0175 SHALL BE CERTIFIED				
B921	Body plain Washer	ASTM F436 ZINC PLATED				
		410 ST ST HRC 35-45				
B921a	Packing Plain Washer <sup>(4)</sup>	ASTM F436 ZINC PLATED				
		410 ST ST HRC 35-45				

Notes:

1. For General Service only: Nace Non-Exposed per ANSI/NACE MR0175/ISO 15156-1.
2. For Sour Service only: Nace Exposed per ANSI/NACE MR0175/ISO 15156-1.
3. Considered as pressure containing parts in API 6A specification.
4. Zinc electroplating is not permitted for splash zone or subsea service.
5. Blue is the standard coating color.
6. No equivalents allowed to maintain fugitive emission certification and performance.

# Materials of Construction

## Super Duplex F55 Stainless Construction

41005 API 6A Super Duplex F55 Stainless-Steel construction is covering:

- Max operating pressure up to 15 kPSI [1034 bar]
- Temperature class: L/N/P/S/T/U/V/X (Refer to table on page 41)
- Material class: AA/BB/CC/FF (Refer to table on page 41)

Ref. No.	Temperature Range	-46°C [-50°F]	-29°C [-20.2°F]	121°C [250°F]	180°C [356°F]	
		Materials				
B001	Valve Body	ASTM A182 GR F55 API6A				
		ASTM A182 GR F55 API6A ELEVATED TEMPERATURE X (see page 41)				
B002	Body Stud <sup>(4)</sup>		ASTM A193 GRADE B7 ZINC PLATED + PTFE COATING API6A <sup>(1 &amp; 5)</sup>			
			ASTM A193 GR B7M ELECTROLESS NICKEL PLATING + PTFE COATING <sup>(2 &amp; 5)</sup>			
			ASTM A320 Gr L7 ZINC PLATED + PTFE COATING <sup>(1 &amp; 5)</sup>			
			ASTM A320 Gr L7M ELECTROLESS NICKEL PLATING + PTFE COATING <sup>(2 &amp; 5)</sup>			
B003	Bonnet	ASTM A182 GR F55 API6A				
		ASTM A182 GR F55 API6A ELEVATED TEMPERATURE X (see page 41)				
B014	Body Nut <sup>(4)</sup>		ASTM A 194 GR 2H ZINC PLATED + PTFE COATING <sup>(1 &amp; 5)</sup>			
			ASTM A194 GR 2HM, ELECTROLESS NICKEL PLATING + PTFE COATING <sup>(2 &amp; 5)</sup>			
			ASTM A194 Gr 7 ZINC PLATED + PTFE COATING <sup>(1 &amp; 5)</sup>			
			ASTM A194 Gr 7M ELECTROLESS NICKEL PLATING + PTFE COATING <sup>(2 &amp; 5)</sup>			
B015	Body Gasket	ALLOY 718 + MOS2 COATING				
B103	Seat Ring Gasket	INCONEL 718 + SILVER PLATING				
B105	Retainer	SUPER AUSTENITIC STAINLESS STEEL UNS S20910 (NITRONIC 50) 35 HRC MAXIMUM				
B107	Cage	ASTM A 479 UNS S32760 + STELLITE N°6 + CHROME PLATING				
B108	Cage Gasket	PRESSURE ENERGIZED POLYMERIC				
B110	Outer Cage	SUPER DUPLEX AUSTENO-FERRITIQUE STAINLESS STEEL (TYPE UNS S32760) HRC 32 MAXIMUM]				
B112	Plug	HARDFACING STELL N°6 ON SOLUTION ANNEALED SUPER DUPLEX AUSTENO-FERRITIQUE STAINLESS STEEL (TYPE UNS S32760) HRC 32 MAXIMUM				
B118	Plug Balanced Seal	PRESSURE ENERGIZED POLYMERIC				

## Super Duplex F55 Stainless Steel construction (Cont.)

Ref. No.	Temperature Range	-46°C [-50°F]	-29°C [-20.2°F]	121°C [250°F]	180°C [356°F]	
		Materials				
B150	Plug Stem <sup>(3)</sup>	ASTM A182 GR F55 API6A				
		ASTM A182 GR F55 API6A ELEVATED TEMPERATURE X (see page 41)				
B203	Packing Bushing	STELLITE NO.6 OR EQUIVALENT				
B207	Packing Ring	CARBON CORE PTFE <sup>(6)</sup>				
B208	Anti Extrusion Ring	CARBON-GRAPHITE BRAIDED <sup>(6)</sup>				
B219	Packing Flange/ Follower <sup>(3)</sup>	ASTM A182 GR F55 API6A				
		ASTM A182 GR F55 API6A ELEVATED TEMPERATURE X (see page 41)				
B220	Packing Stud <sup>(4)</sup>				ASTM A193 GRADE B7 ZINC PLATED <sup>(1)</sup>	
					ASTM A193 GR B7M ELECTROLESS NICKEL PLATING <sup>(2)</sup>	
					ASTM A320 Gr L7 ZINC PLATED <sup>(1)</sup>	
					ASTM A320 Gr L7M ELECTROLESS NICKEL PLATING <sup>(2)</sup>	
B221	Packing Nut <sup>(4)</sup>				ASTM A 194 GR 2H ZINC PLATED <sup>(1)</sup>	
					ASTM A194 GR 2HM, ELECTROLESS NICKEL PLATING <sup>(2)</sup>	
					ASTM A194 GR 7 ZINC PLATED <sup>(1)</sup>	
					ASTM A194 GR 7M ELECTROLESS NICKEL PLATING <sup>(2)</sup>	
B903	Plug Pin	SUPER DUPLEX AUSTENO-FERRITIQUE STAINLESS STEEL (TYPE UNS S32760) HRC 32 MAXIMUM				
B914	Cage Set Screw	SOLUTION ANNEALED 316L HRC 22 MAXIMUM STAINLESS STEEL HARDNESS COMPLIANCE WITH NACE MR0103 & MR0175 SHALL BE CERTIFIED				
B921	Body plain Washer <sup>(4)</sup>	ASTM F436 ZINC PLATED				
		410 ST ST HRC 35-45				
B921a	Packing Plain Washer <sup>(4)</sup>	ASTM F436 ZINC PLATED				
		410 ST ST HRC 35-45				

Notes:

1. For General Service only: Nace Non-Exposed per ANSI/NACE MR0175/ISO 15156-1
2. For Sour Service only: Nace Exposed per ANSI/NACE MR0175/ISO 15156-1
3. Considered as pressure containing parts in API 6A specification
4. Zinc electroplating is not permitted for splash zone or subsea service.
5. Blue is the standard coating color.
6. No equivalents allowed to maintain fugitive emission certification and performance.

# Materials of Construction

## CRA Inconel 718 Construction

41005 API 6A CRA Inconel 718 construction is covering:

- Max operating pressure is up to 15 kPSI [1034 bar]
- Temperature class: K/L/N/P/S/T/U/V/X (Refer to table on page 41)
- Material class: AA/BB/CC/DD/EE/FF/HH (Refer to table on page 41)

Ref. No.	Temperature Range	-60°C [-76°F]	-29°C [-20.2°F]	121°C [250°F]	180°C [356°F]	
		Materials				
B001	Valve Body	UNS N07718				
		UNS N07718 ELEVATED TEMPERATURE X (see page 41)				
B002	Body Stud <sup>(4)</sup>	ASTM A193 GRADE B7 ZINC PLATED + PTFE COATING API6A <sup>(1 &amp; 5)</sup>				
		ASTM A193 GR B7M ELECTROLESS NICKEL PLATING + PTFE COATING <sup>(2 &amp; 5)</sup>				
		ASTM A320 Gr L7 ZINC PLATED + PTFE COATING <sup>(1 &amp; 5)</sup>				
		ASTM A320 Gr L7M ELECTROLESS NICKEL PLATING + PTFE COATING <sup>(2 &amp; 5)</sup>				
B003	Bonnet	UNS N07718				
		UNS N07718 ELEVATED TEMPERATURE X (see page 41)				
B014	Body Nut <sup>(4)</sup>	ASTM A 194 GR 2H ZINC PLATED + PTFE COATING <sup>(1 &amp; 5)</sup>				
		ASTM A194 GR 2HM, ELECTROLESS NICKEL PLATING + PTFE COATING <sup>(2 &amp; 5)</sup>				
		ASTM A194 Gr 7 ZINC PLATED + PTFE COATING <sup>(1 &amp; 5)</sup>				
		ASTM A194 Gr 7M ELECTROLESS NICKEL PLATING + PTFE COATING <sup>(2 &amp; 5)</sup>				
B015	Body Gasket	ALLOY 718 + MOS2 COATING				
B103	Seat Ring Gasket	INCONEL 718 + SILVER PLATING				
B105	Retainer	SUPER AUSTENITIC STAINLESS STEEL UNS S20910 (NITRONIC 50) 35 HRC MAXIMUM				
B107	Cage	UNS N07718				
		UNS N07718 ELEVATED TEMPERATURE X (see page 41)				
B108	Cage Gasket	PRESSURE ENERGIZED POLYMERIC				
B110	Outer Cage	UNS N07718				
		UNS N07718 ELEVATED TEMPERATURE X (see page 41)				
B112	Plug	UNS N07718				
		UNS N07718 ELEVATED TEMPERATURE X (see page 41)				
B118	Plug Balanced Seal	PRESSURE ENERGIZED POLYMERIC				

## CRA Inconel 718 construction (Cont.)

Ref. No.	Temperature Range	-60°C [-76°F]	-29°C [-20.2°F]	121°C [250°F]	180°C [356°F]	
		Materials				
B150	Plug Stem <sup>(3)</sup>	UNS N07718				
		UNS N07718 ELEVATED TEMPERATURE X (see page 41)				
B220	Packing Stud <sup>(4)</sup>	ASTM A193 GRADE B7 ZINC PLATED <sup>(1)</sup>				
		ASTM A193 GR B7M ELECTROLESS NICKEL PLATING <sup>(2)</sup>				
		ASTM A320 Gr L7 ZINC PLATED(1)				
		ASTM A320 Gr L7M ELECTROLESS NICKEL PLATING (2)				
B221	Packing Nut <sup>(4)</sup>	ASTM A 194 GR 2H ZINC PLATED <sup>(1)</sup>				
		ASTM A194 GR 2HM, ELECTROLESS NICKEL PLATING				
		ASTM A194 GR 7 ZINC PLATED				
		ASTM A194 GR 7M ELECTROLESS NICKEL PLATING				
B203	Packing Bushing	STELLITE NO.6 OR EQUIVALENT				
B207	Packing Ring	CARBON CORE PTFE <sup>(6)</sup>				
B208	Anti Extrusion Ring	CARBON-GRAPHITE BRAIDED <sup>(6)</sup>				
B213	Packing Flange/ Follower <sup>(3)</sup>	UNS N07718				
		UNS N07718 ELEVATED TEMPERATURE X (see page 41)				
B903	Plug Pin	ASTM B637 GRADE NO7718 (UNS 07718) HRc 40 MAXIMUM . HARDNESS COMPLIANCE WITH NACE MR0103 SHALL BE CERTIFIED				
B914	Cage Set Screw	ASTM B637 GRADE NO7718 (UNS 07718) HRc 40 MAXIMUM. HARDNESS COMPLIANCE WITH NACE MR0103 SHALL BE CERTIFIED				
B921	Body plain Washer <sup>(4)</sup>	ASTM F436 ZINC PLATED				
		410 ST ST HRC 35-45				
B921a	Packing Plain Washer <sup>(4)</sup>	ASTM F436 ZINC PLATED				
		410 ST ST HRC 35-45				

Notes:

1. For General Service only: Nace Non-Exposed per ANSI/NACE MR0175/ISO 15156-1.
2. For Sour Service only: Nace Exposed per ANSI/NACE MR0175/ISO 15156-1.
3. Considered as pressure containing parts in API 6A specification.
4. Zinc electroplating is not permitted for splash zone or subsea service.
5. Blue is the standard coating color.
6. No equivalents allowed to maintain fugitive emission certification and performance.

## Common Parts

Ref. No.	Temperature Range	-60°C [-76°F]	-29°C [-20.2°F]	121°C [250°F]	180°C [356°F]
		Materials			
B017	Drive Nut	SOLUTION ANNEALED 316 STAINLESS STEEL HRc 22 MAXIMUM			
B703	Serial Plate	GENERAL SERVICE ANNEALED 316L ST ST HRc 22 MAX			
B704	Flow Arrow	AUSTENITIC STAINLESS STEEL			
B902	Drive Screw	AUSTENITIC STAINLESS STEEL			
B911	Lifting Lugs	STAINLESS STEEL			
B913	Yoke/Bonnet Screw	A4-80 (ISO 3506) 316L			

# Dimensions

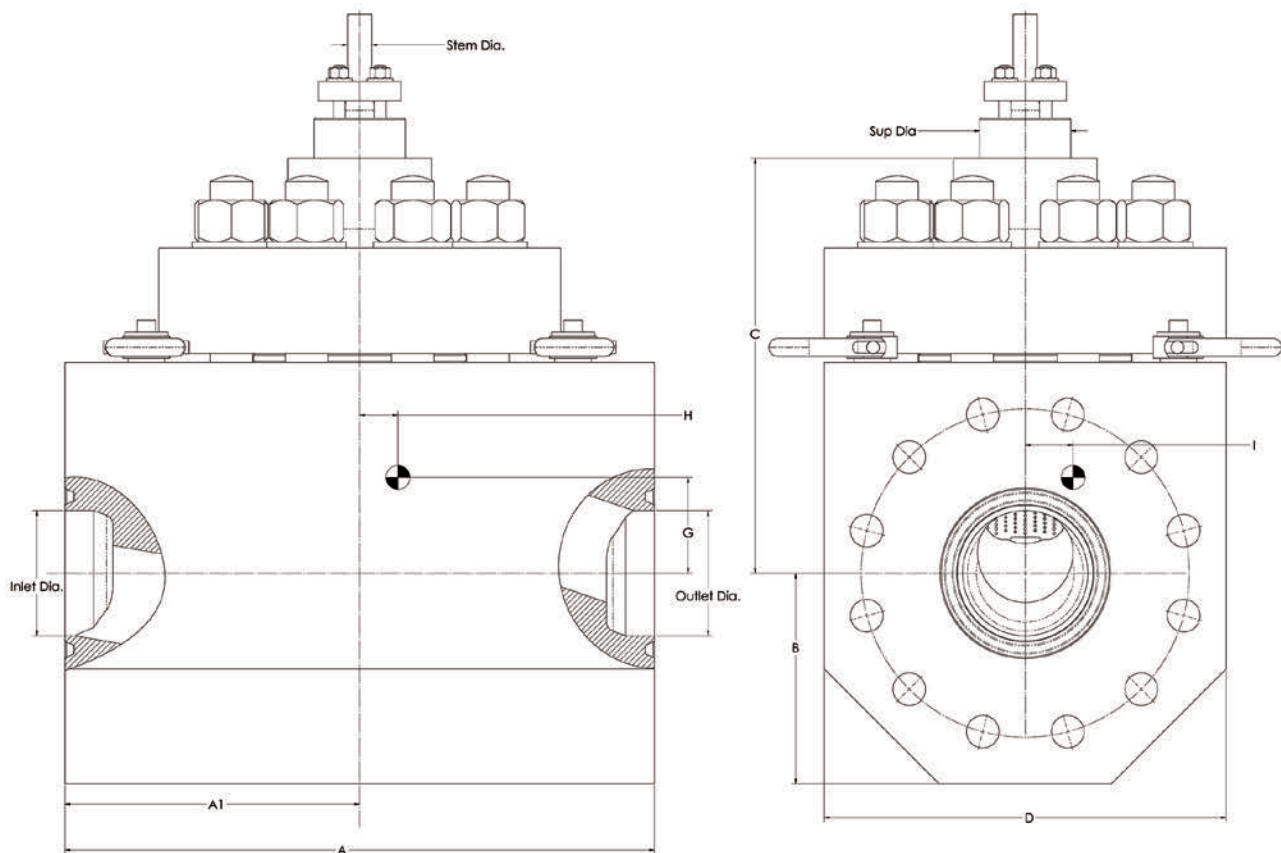

## Inches API 10K & 15K Body S/A dimensions

Valve Body Size (NPS)	Valve Ends Size (NPS)	Stem Dia.	Inlet Dia.	Outlet Dia.	Spud Dia.	API 10K & API 10K Design 120K					API 15K & API 15K Design 120K				
						6BX					6BX				
						A	A1	B	C	D	A	A1	B	C	D
3	4 <sup>1</sup> / <sub>16</sub> (4.0625)	1	4.08	4.08	3.75	20.47	10.23	6.38	16.43	14.76	20.47	10.23	7.16	16.43	15.75
4	5 <sup>1</sup> / <sub>8</sub> (5.125)	1	5.15	5.15	3.75	24.25	12.13	8.66	17	14.96	24.25	12.13	8.66	17	16.54
6	7 <sup>1</sup> / <sub>16</sub> (7.0625)	1.125	7.09	7.09	5	27.56	13.78	9.45	19.35	19.17	27.56	13.78	10.04	19.35	20.08
8	9"	1.25	8.27	8.27	5	34.64	17.32	13	22.19	24.4	34.64	17.32	13	22.19	26
10	11"	1.25	10.12	10.12	5	40.55	20.28	13.78	25.74	27.17	40.55	20.28	16.34	25.74	32

## mm API 10K & 15K Body S/A dimensions

Valve Trim Size (NPS)	Valve Ends Size (NPS)	Stem Dia.	Inlet Dia.	Outlet Dia.	Spud Dia.	API 10K & API 10K Design 120K					API 15K & API 15K Design 120K				
						6BX					6BX				
						A	A1	B	C	D	A	A1	B	C	D
3	4 <sup>1</sup> / <sub>16</sub> (4.0625)	25.4	103.65	103.65	95.25	520	260	162	417	375	520	260	182	417	400
4	5 <sup>1</sup> / <sub>8</sub> (5.125)	25.4	130.85	130.85	95.25	616	308	220	433	380	616	308	220	433	420
6	7 <sup>1</sup> / <sub>16</sub> (7.0625)	28.575	180.1	180.1	127	700	350	240	491.5	487	700	350	255	491.5	510
8	9"	31.75	210	210	127	880	440	330	564	620	880	440	330	563.5	660
10	11"	31.75	257	257	127	1030	515	350	654	690	1030	515	415	654	814

# Weights / Center of Gravity

## Body S/A (lbs.) / Center of Gravity (inches)

Valve Body Size (NPS)	Valve Ends Size (NPS)	API 10K				API 15K			
		6BX Printed Flange				6BX Printed Flange			
		G	H	I	Mass	G	H	I	Mass
3	4"1/16 (4.0625)	3.3	0	0	1216	3	0	0	1410
4	5"1/8 (5.125)	2.2	0	0	1672	2.4	0	0	1917
6	7"1/16 (7.0625)	3.56	0	0	2943	3.28	0	0	3343
8	9"	3.8	0	0	5886	4.14	0	0	6489
10	11"	5	0	0	8597	3.67	0	0	10898

Valve Body Size (NPS)	Valve Ends Size (NPS)	API 10K Design 120K				API 15K Design 120K			
		6BX Printed Flange				6BX Printed Flange			
		G	H	I	Mass	G	H	I	Mass
3	4"1/16 (4.0625)	3	0	0	1172	2.6	0	0	1354
4	5"1/8 (5.125)	1.8	0	0	1645	2	0	0	1917
6	7"1/16 (7.0625)	3.17	0	0	2855	2.85	0	0	3238
8	9"	3.18	0	0	5673	3.5	0	0	6237
10	11"	4.32	0	0	8319	3.15	0	0	10628

## Body S/A (kg) / Center of Gravity (mm)

Valve Trim Size (NPS)	Valve Ends Size (NPS)	API 10K				API 15K			
		6BX Printed Flange				6BX Printed Flange			
		G	H	I	Mass	G	H	I	Mass
3	4"1/16 (4.0625)	83	0	0	552	76	0	0	640
4	5"1/8 (5.125)	54	0	0	758	61	0	0	870
6	7"1/16 (7.0625)	90	0	0	1335	83	0	0	1516
8	9"	97	0	0	2670	105	0	0	2943
10	11"	125	0	0	3900	93	0	0	4941

Valve Trim Size (NPS)	Valve Ends Size (NPS)	API 10K Design 120K				API 15K Design 120K			
		6BX Printed Flange				6BX Printed Flange			
		G	H	I	Mass	G	H	I	Mass
3	4"1/16 (4.0625)	75	0	0	532	66	0	0	614
4	5"1/8 (5.125)	47	0	0	746	51	0	0	870
6	7"1/16 (7.0625)	81	0	0	1295	72	0	0	1469
8	9"	81	0	0	2573	89	0	0	2829
10	11"	110	0	0	3774	80	0	0	4821

# 87/88 Actuators - Dimensions and Weights (U.S.)

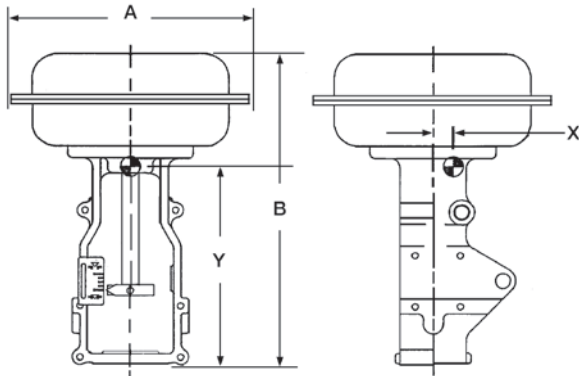

Shown without optional Handwheel

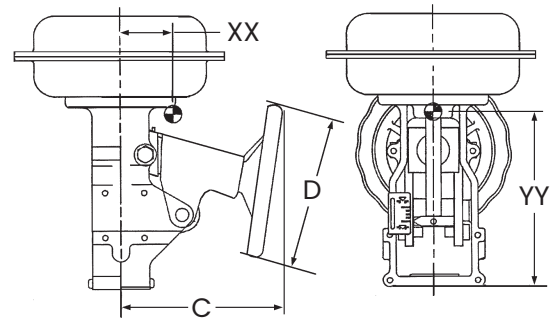

Shown with optional Handwheel

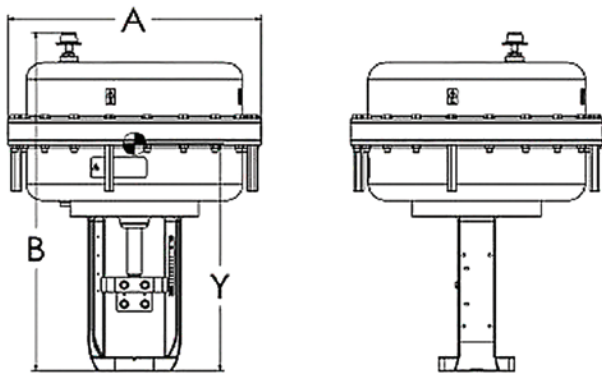

23L Shown without optional Handwheel

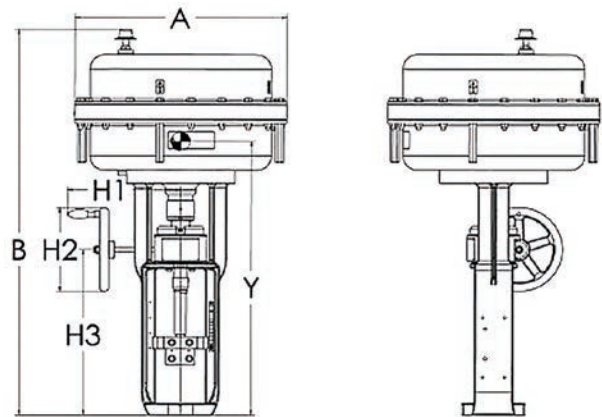

23L Shown with optional Handwheel

## Dimensions and Weights

Actuator Size	Spring Range	Actuator Dimensions (inches)				H1	H2	Weights (lbs.)	
		A	B (Model 88)	C	D			Standard	w/Handwheel
6	All	11.5	15.54 (17.52)	10	9	-	-	45	60
10	All	14.5	19.58 (21.54)	10.9	12	-	-	85	105
16	All	18.75	28.22 (30.79)	14	18	-	-	210	245
23	All	21.63	30.71 (33.27)	16	18	-	-	265	320
23L	3-15, 6-30	21.63	27.8 (30.00)	-	-	11.5	8.9	375	417
23L	11-23, 21-45	21.63	38.55 (40.75)	-	-	11.5	8.9	507	549

Actuator Removal Clearance = 6 inches

## Center of Gravity (inches)

Without Handwheel

Size	X	Y
6	0.2	9.8
10	0.0	12.9
16	0.1	18.5
23	0.1	21.1
23L <sup>1</sup>	0.0	20.1
23L <sup>2</sup>	0.0	21.9

With Handwheel

Size	XX	YY
6	1.3	9.1
10	0.9	12.0
16	1.4	16.7
23	1.4	19.0
23L <sup>1</sup>	0.0	28.9
23L <sup>2</sup>	0.0	30.7

1. Nominal spring ranges 3-15 & 6-30

2. Nominal spring ranges 11-23 & 21-45



# 87/88 Actuators – Dimensions and Weights (U.S.)

## Limit Stops (inches)

### Up Stop

Size	Spring Range	Model	Overall Height B
6	All	87	19.5
10	All		25.4
16	All		36.4
23	All		38.8
23L <sup>1</sup>	3-15, 6-30		38.4
23L <sup>1</sup>	11-23, 21-45		41.3
23L <sup>2</sup>	3-15, 6-30		49.1
23L <sup>2</sup>	11-23, 21-45		52.1
6	All	88	19.2
10	All		25.1
16	All		35.5
23	All		35.5
23L <sup>1</sup>	3-15, 6-30		38.4
23L <sup>1</sup>	11-23, 21-45		41.3
23L <sup>2</sup>	3-15, 6-30		49.1
23L <sup>2</sup>	11-23, 21-45		52.1

### Down Stop

Size	Spring Range	Model	Overall Height B
6	All	87	19.8
10	All		26.0
16	All		37.2
23	All		39.9
23L <sup>1</sup>	3-15, 6-30		39.9
23L <sup>1</sup>	11-23, 21-45		42.8
23L <sup>2</sup>	3-15, 6-30		50.6
23L <sup>2</sup>	11-23, 21-45		53.6
6	All	88	19.7
10	All		25.9
16	All		37.5
23	All		40.3
23L <sup>1</sup>	3-15, 6-30		39.9
23L <sup>1</sup>	11-23, 21-45		42.8
23L <sup>2</sup>	3-15, 6-30		50.6
23L <sup>2</sup>	11-23, 21-45		53.6

1. Without Handwheel
2. With Handwheel

# 87/88 Actuators - Dimensions and Weights (Metric)

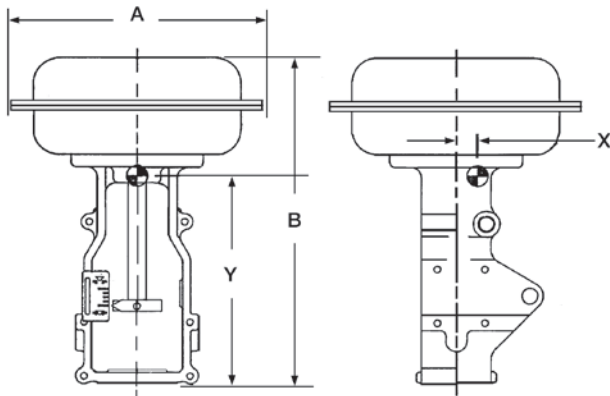

Shown without optional Handwheel

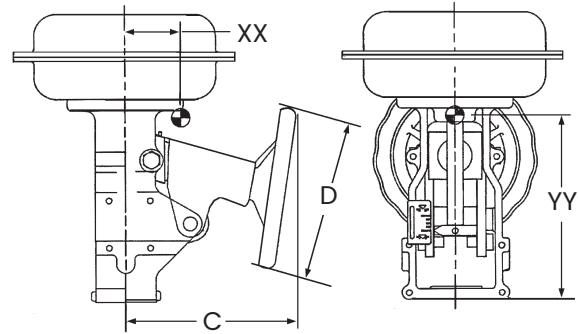

Shown with optional Handwheel

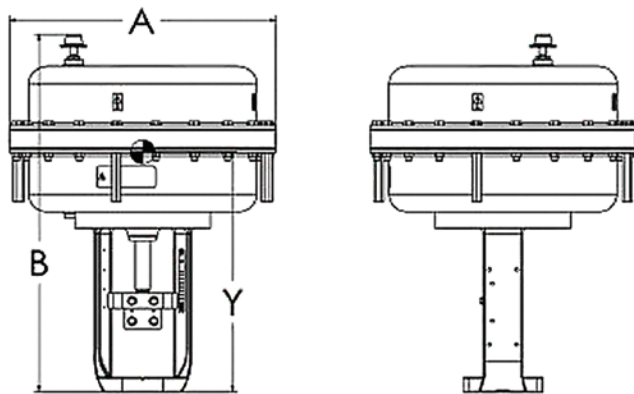

23L Shown without optional Handwheel

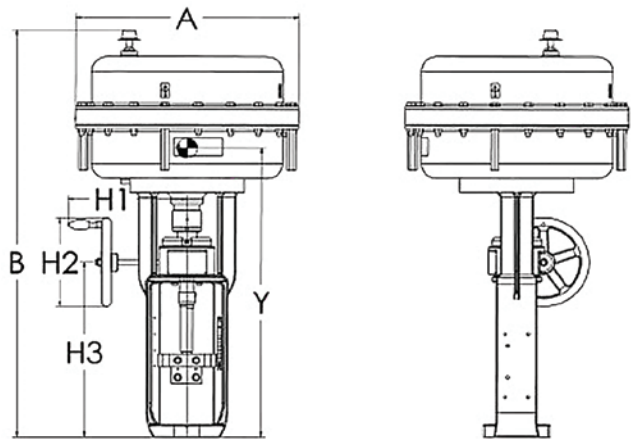

23L Shown with optional Handwheel

## Dimensions and Weights

Actuator Size	Spring Range	Actuator Dimensions (mm)				H1	H2	Weights (kg)	
		A	B (Model 88)	C	D			Standard	w/Handwheel
6	All	302	395 (445)	254	229	-	-	20	27
10	All	373	497 (547)	277	305	-	-	39	48
16	All	476	717 (782)	356	457	-	-	95	111
23	All	549	780 (845)	406	457	-	-	120	145
23L	3-15, 6-30	549	706 (762)	-	-	292	225	170	189
23L	11-23, 21-45	549	781 (837)	-	-	292	225	230	249

Actuator Removal Clearance = 150 mm

## Center of Gravity (mm)

### Without Handwheel

Size	X	Y
6	5	248
10	0	327
16	3	470
23	2	537
23L <sup>1</sup>	0	511
23L <sup>2</sup>	0	557

### With Handwheel

Size	XX	YY
6	32	232
10	22	305
16	35	425
23	35	483
23L <sup>1</sup>	0	734
23L <sup>2</sup>	0	780

1. Nominal spring ranges 3-15 & 6-30  
2. Nominal spring ranges 11-23 & 21-45

# 87/88 Actuators – Dimensions and Weights (Metric)

## Limit Stops (mm)

### Up Stop

Size	Spring Range	Model	Overall Height B	
6	All	87	494	
10	All		646	
16	All		925	
23	All		987	
23L <sup>1</sup>	3-15, 6-30		975	
23L <sup>1</sup>	11-23, 21-45		1050	
23L <sup>2</sup>	3-15, 6-30		1248	
23L <sup>2</sup>	11-23, 21-45		1323	
6	All		88	487
10	All			636
16	All	901		
23	All	982		
23L <sup>1</sup>	3-15, 6-30	975		
23L <sup>1</sup>	11-23, 21-45	1050		
23L <sup>2</sup>	3-15, 6-30	1248		
23L <sup>2</sup>	11-23, 21-45	1323		

### Down Stop

Size	Spring Range	Model	Overall Height B	
6	All	87	503	
10	All		660	
16	All		945	
23	All		1014	
23L <sup>1</sup>	3-15, 6-30		1013	
23L <sup>1</sup>	11-23, 21-45		1088	
23L <sup>2</sup>	3-15, 6-30		1286	
23L <sup>2</sup>	11-23, 21-45		1361	
6	All		88	501
10	All			657
16	All	952		
23	All	1024		
23L <sup>1</sup>	3-15, 6-30	1013		
23L <sup>1</sup>	11-23, 21-45	1088		
23L <sup>2</sup>	3-15, 6-30	1286		
23L <sup>2</sup>	11-23, 21-45	1361		

1. Without Handwheel

2. With Handwheel

# 51/52/53 Actuators - Dimensions

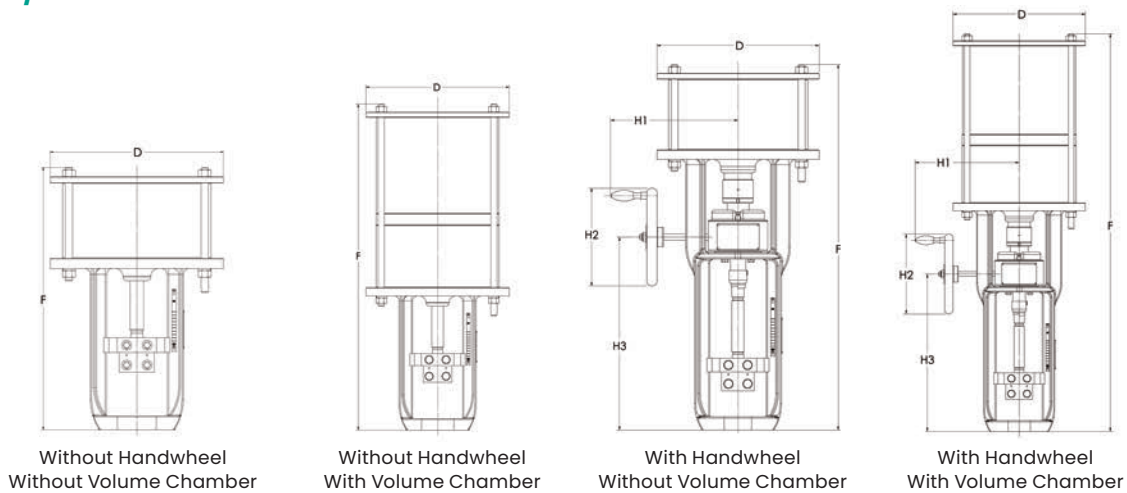

## Model 51 Dimensional Data

### Inches (mm)

Size	D	H1	H2	H3
12	14.7 (373)	11.5 (292)	8.9 (225)	17.4 (443)
16	18.1 (461)	13.4 (340)	11 (280)	21.7 (553)
20	22.6 (573)	13.4 (340)	11 (280)	22.1 (563)
24	18.1 (461)	13.4 (340)	11 (280)	22.1 (563)
28	22.6 (573)	13.4 (340)	11 (280)	22.1 (563)
32	26.4 (670)	13.4 (340)	11 (280)	22.2 (564)

Actuator Type	Actuator Size	Dimension F inches (mm)					
		Nominal Actuator Travel inches (mm)					
		2.5 (63.5)	4 (101.6)	6 (152.4)	8 (203.2)	10 (254)	12 (304.8)
Standard	12	-	23.0 (584)	-	-	-	-
	16	24.7 (628)	26.2 (666)	28.2 (717)	36.2 (920)	38.2 (971)	42.2 (1073)
	20	25.4 (645)	26.9 (683)	28.9 (734)	36.7 (931)	38.7 (982)	45.0 (1142)
	24	33.1 (842)	36.1 (918)	40.1 (1020)	48.1 (123)	52.1 (1324)	60.2 (1528)
	28	34.3 (870)	37.3 (946)	52.2 (1326)	49.3 (1251)	53.3 (1353)	61.3 (1556)
	32	42.7 (1085)	45.7 (1161)	49.7 (1262)	57.8 (1467)	61.8 (1569)	69.8 (1773)
Standard with Integral Volume Tank	12	-	34.0 (864)	-	-	-	-
	16	35.8 (908)	37.3 (946)	39.3 (997)	-	-	-
	20	36.0 (915)	37.5 (953)	39.5 (1004)	-	-	-
Standard with Handwheel	12	-	33.7 (857)	-	-	-	-
	16	40.6 (1031)	42.1 (1069)	44.1 (1119)	59.3 (1506)	61.3 (1557)	69.3 (1760)
	20	41.2 (1048)	42.7 (1086)	44.7 (1136)	59.6 (1513)	61.6 (1564)	69.6 (1767)
	24	48.2 (1224)	51.2 (1301)	55.2 (1402)	71.2 (1808)	75.2 (1910)	85.2 (2164)
	28	49.2 (1249)	52.2 (1326)	53.2 (1427)	72.1 (1831)	76.1 (1933)	86.1 (2187)
	32	56.6 (1440)	59.7 (1516)	63.7 (1617)	79.7 (2025)	83.7 (2126)	93.7 (2381)
Standard with Integral Volume Tank and Handwheel	12	-	44.8 (1137)	-	-	-	-
	16	51.6 (1311)	53.1 (1349)	55.1 (1399)	-	-	-
	20	51.9 (1318)	53.4 (1356)	55.4 (1406)	-	-	-

# 51/52/53 Actuators – Dimensions

## Model 52 and 53 Dimensional Data

### Inches (mm)

Size	D	H1	H2	H3
12	14.69 (373)	11.50 (292)	8.86 (225)	17.44 (443)
16	18.15 (461)	13.39 (340)	11.02 (280)	21.77 (553)
20	22.56 (573)	13.39 (340)	11.02 (280)	22.17 (563)

Actuator Type	Actuator Size	Dimension F in (mm)		
		Nominal Actuator Travel In. (mm)		
		2.5 (63.5)	4 (101.6)	6 (152.4)
Standard	12	-	39.1 (993.8)	-
	16	39.5 (1003)	44 (1117)	50 (1269)
	20	41.1 (1045)	45.6 (1159)	51.6 (1311)
Standard with Handwheel	12	-	49.9 (1267)	-
	16	55.3 (1406)	59.8 (1520)	65.8 (1671)
	20	64.6 (1642)	69.1 (1756)	75.1 (1908)

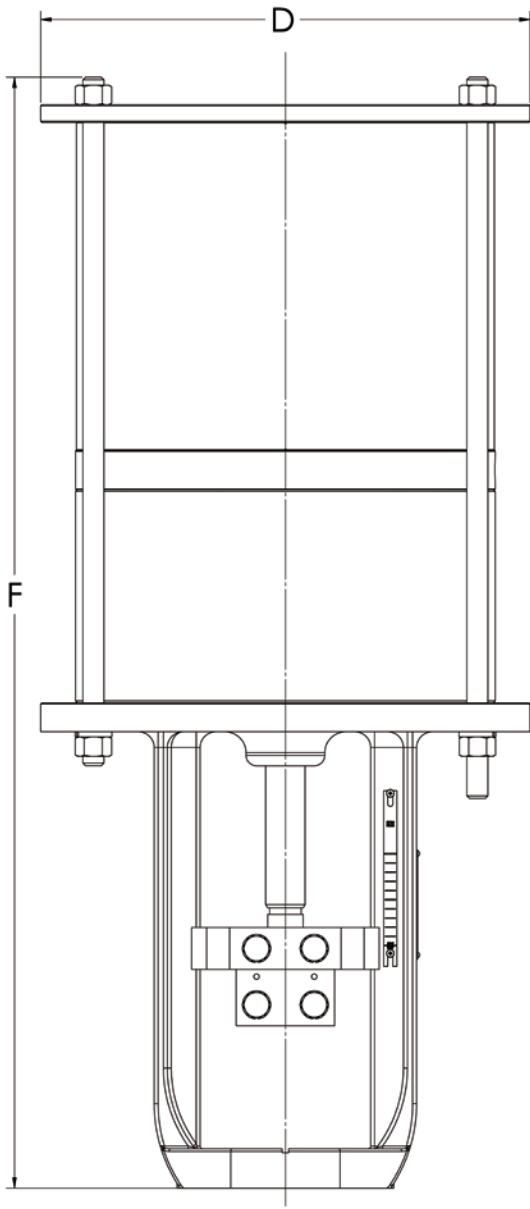

Without Handwheel

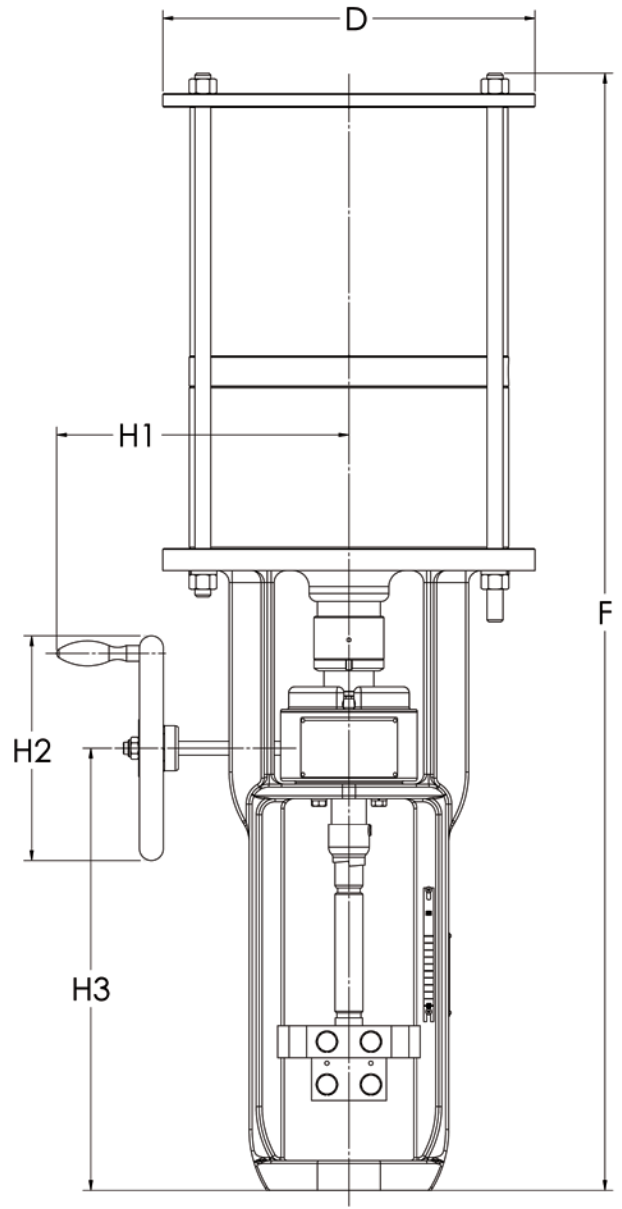

With Handwheel

# 51/52/53 Actuators – Weights

In US Units (lbs)

Actuator Size	Construction	Nominal Stroke in (mm)	Model 51		Model 52		Model 53	
			Without Handwheel	With Handwheel	Without Handwheel	With Handwheel	Without Handwheel	With Handwheel
12	Standard	4 (101.6)	179	227	412	456	410	454
	with Integral Volume Chamber	4 (101.6)	280	328	-	-	-	-
16	Standard	2.5 (63.5)	386	529	712	853	703	849
		4 (101.6)	386	529	761	902	754	897
		6 (152.4)	386	529	864	1005	855	1001
		10 (254)	465	628	-	-	-	-
		12 (304.8)	500	688	-	-	-	-
	with Integral Volume Chamber	2.5 (63.5)	578	721	-	-	-	-
		4 (101.6)	578	721	-	-	-	-
		6 (152.4)	578	721	-	-	-	-
		10 (254)	465	628	-	-	-	-
		12 (304.8)	500	688	-	-	-	-
20	Standard	2.5 (63.5)	639	785	1157	1303	1149	1294
		4 (101.6)	639	785	1261	1407	1252	1398
		6 (152.4)	639	785	1387	1532	1378	1523
		10 (254)	699	849	-	-	-	-
		12 (304.8)	741	919	-	-	-	-
	with Integral Volume Chamber	2.5 (63.5)	919	1065	-	-	-	-
		4 (101.6)	919	1065	-	-	-	-
		6 (152.4)	919	1065	-	-	-	-
		10 (254)	699	849	-	-	-	-
		12 (304.8)	741	919	-	-	-	-
24	Standard	6 (152.4)	714	970	-	-	-	-
		10 (254)	791	1109	-	-	-	-
		12 (304.8)	838	1177	-	-	-	-
28	Standard	6 (152.4)	1190	1362	-	-	-	-
		10 (254)	1305	1506	-	-	-	-
		12 (304.8)	1369	1579	-	-	-	-
32	Standard	6 (152.4)	2116	2299	-	-	-	-
		10 (254)	2235	2449	-	-	-	-
		12 (304.8)	2304	2522	-	-	-	-

# 51/52/53 Actuators – Weights

## In Metric Units (kg)

Actuator Size	Construction	Nominal Stroke in (mm)	Model 51		Model 52		Model 53	
			Without Handwheel	With Handwheel	Without Handwheel	With Handwheel	Without Handwheel	With Handwheel
12	Standard	4 (102)	81	103	187	207	186	206
	with Integral Volume Chamber	4 (102)	127	149	-	-	-	-
16	Standard	2.5 (64)	175	240	323	387	319	385
		4 (102)	175	240	345	409	342	407
		6 (152)	175	240	392	456	388	454
		10 (254)	211	285	-	-	-	-
		12 (305)	227	312	-	-	-	-
	with Integral Volume Chamber	2.5 (64)	262	327	-	-	-	-
		4 (102)	262	327	-	-	-	-
		6 (152)	262	327	-	-	-	-
		10 (254)	211	285	-	-	-	-
		12 (305)	227	312	-	-	-	-
20	Standard	2.5 (64)	290	356	525	591	521	587
		4 (102)	290	356	572	638	568	634
		6 (152)	290	356	629	695	625	691
		10 (254)	317	385	-	-	-	-
		12 (305)	336	417	-	-	-	-
	with Integral Volume Chamber	2.5 (64)	417	483	-	-	-	-
		4 (102)	417	483	-	-	-	-
		6 (152)	417	483	-	-	-	-
		10 (254)	317	385	-	-	-	-
		12 (305)	336	417	-	-	-	-
24	Standard	6 (152)	324	440	-	-	-	-
		10 (254)	359	503	-	-	-	-
		12 (305)	380	534	-	-	-	-
28	Standard	6 (152)	540	618	-	-	-	-
		10 (254)	592	683	-	-	-	-
		12 (305)	621	716	-	-	-	-
32	Standard	6 (152)	960	1043	-	-	-	-
		10 (254)	1014	1111	-	-	-	-
		12 (305)	1045	1144	-	-	-	-





# Find the nearest local Channel Partner in your area:

[valves.bakerhughes.com/contact-us](https://valves.bakerhughes.com/contact-us)

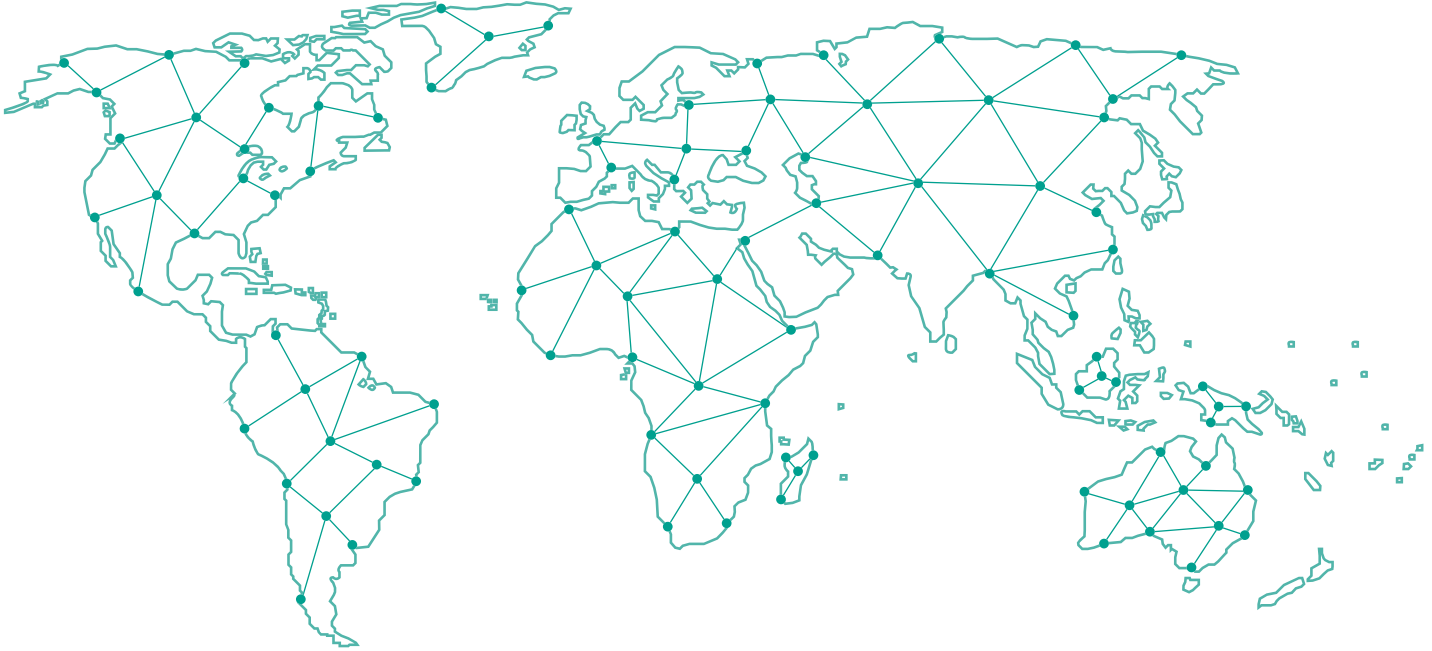

## Tech Field Support & Warranty:

Phone: +1-866-827-5378  
[valvesupport@bakerhughes.com](mailto:valvesupport@bakerhughes.com)

[valves.bakerhughes.com](https://valves.bakerhughes.com)

Copyright 2023 Baker Hughes Company. All rights reserved. Baker Hughes provides this information on an "as is" basis for general information purposes. Baker Hughes does not make any representation as to the accuracy or completeness of the information and makes no warranties of any kind, specific, implied or oral, to the fullest extent permissible by law, including those of merchantability and fitness for a particular purpose or use. Baker Hughes hereby disclaims any and all liability for any direct, indirect, consequential or special damages, claims for lost profits, or third party claims arising from the use of the information, whether a claim is asserted in contract, tort, or otherwise. Baker Hughes reserves the right to make changes in specifications and features shown herein, or discontinue the product described at any time without notice or obligation. Contact your Baker Hughes representative for the most current information. The Baker Hughes logo, Masoneilan, and Lo-dB are trademarks of Baker Hughes Company. Other company names and product names use

**Baker Hughes** 

[bakerhughes.com](https://bakerhughes.com)