

# DigitalFlow™ XGF868i

## Flare Gas Mass Flow Ultrasonic Transmitter Startup Guide





# DigitalFlow™ XGF868i

## Flare Gas Mass Flow Ultrasonic Transmitter

### Startup Guide

BH060C41 EN D  
April 2023

[panametrics.com](https://panametrics.com)

Copyright 2023 Baker Hughes company.

This material contains one or more registered trademarks of Baker Hughes Company and its subsidiaries in one or more countries. All third-party product and company names are trademarks of their respective holders.

[no content intended for this page]

## Information Paragraphs

**Note:** *These paragraphs provide information that provides a deeper understanding of the situation, but is not essential to the proper completion of the instructions.*

**IMPORTANT:** These paragraphs provide information emphasizing instructions which are essential to proper setup of the equipment. Failure to follow these instructions carefully may cause unreliable performance.



**WARNING!** Indicates a potentially hazardous situation which can result in serious personal injury or death, if it is not avoided.



**CAUTION!** Indicates a potentially hazardous situation which can result in minor or moderate injury to personnel or damage to the equipment, if it is not avoided.



**HIGH VOLTAGE!** This symbol indicates the presence of high voltage. It calls your attention to situations or operations that could be dangerous to you and other persons operating the equipment. Read these messages and follow the instructions carefully.

## Safety Issues



**WARNING!** It is the responsibility of the user to make sure all local, county, state and national codes, regulations, rules and laws related to safety and safe operating conditions are met for each installation.

## Auxiliary Equipment

### Local Safety Standards

The user must make sure that he operates all auxiliary equipment in accordance with local codes, standards, regulations, or laws applicable to safety.

### Working Area



**WARNING!** Auxiliary equipment may have both manual and automatic modes of operation. As equipment can move suddenly and without warning, do not enter the work cell of this equipment during automatic operation, and do not enter the work envelope of this equipment during manual operation. If you do, serious injury can result.



**WARNING!** Make sure that power to the auxiliary equipment is turned OFF and locked out before you perform maintenance procedures on the equipment.

## Qualification of Personnel

Make sure that all personnel have manufacturer-approved training applicable to the auxiliary equipment.

## Personal Safety Equipment

Make sure that operators and maintenance personnel have all safety equipment applicable to the auxiliary equipment. Examples include safety glasses, protective headgear, safety shoes, etc.

## Unauthorized Operation

Make sure that unauthorized personnel cannot gain access to the operation of the equipment.

## Environmental Compliance

### Waste Electrical and Electronic Equipment (WEEE) Directive

Panametrics is an active participant in Europe's *Waste Electrical and Electronic Equipment (WEEE)* take-back initiative, directive 2012/19/EU.

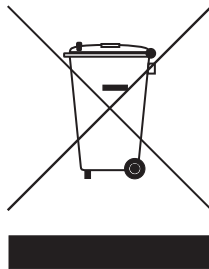

The equipment that you bought has required the extraction and use of natural resources for its production. It may contain hazardous substances that could impact health and the environment.

In order to avoid the dissemination of those substances in our environment and to diminish the pressure on the natural resources, we encourage you to use the appropriate take-back systems. Those systems will reuse or recycle most of the materials of your end life equipment in a sound way.

The crossed-out wheeled bin symbol invites you to use those systems.

If you need more information on the collection, reuse and recycling systems, please contact your local or regional waste administration.

<b>Chapter 1. Installation</b> .....	<b>1</b>
1.1 Introduction .....	1
1.2 Unpacking .....	1
1.3 Site Considerations .....	2
1.3.1 Electronics Enclosure Location .....	2
1.3.2 Flowcell Location .....	2
1.3.3 Transducer Location .....	2
1.3.4 Cable Lengths .....	3
1.3.5 Temperature and Pressure Transmitters .....	3
1.3.6 Transducer Cables .....	3
1.4 Installing a Flowcell .....	3
1.5 Installing Temperature and Pressure Transmitters .....	4
1.6 Mounting the XGF868i Electronics Enclosure .....	5
1.7 Making the Electrical Connections .....	5
1.7.1 Wiring the Line Power .....	7
1.7.2 Wiring the Transducers and Preamplifiers .....	8
1.7.3 Wiring Std 0/4-20 mA Analog Outputs .....	10
1.7.4 Wiring the Serial Port .....	10
1.7.5 Wiring the Option Cards .....	12
<b>Chapter 2. Initial Setup</b> .....	<b>23</b>
2.1 Introduction .....	23
2.2 Programming Methods .....	23
2.3 The XGF868i Keypad .....	24
2.4 Entering Data in the GLOBL Menu .....	25
2.4.1 Entering Global System Data .....	25
2.5 Activating a Channel .....	27
2.6 Entering System Data for the Channel .....	27
2.6.1 Accessing the Channelx-System Submenu .....	27
2.6.2 Selecting Volumetric Units .....	27
2.6.3 Selecting Totalizer Units .....	27
2.6.4 Selecting Mass Flow Units .....	28
2.7 Entering Transducer and Pipe Parameters .....	28
2.7.1 Special Transducers .....	28
2.7.2 Pipe Data .....	29
2.7.3 Path and Axial Lengths .....	29
<b>Chapter 3. Operation</b> .....	<b>33</b>
3.1 Introduction .....	33
3.2 Powering Up .....	33
3.3 The LCD Display .....	34
3.4 The Optional PanaView Display .....	35
3.5 Taking Measurements .....	36
3.5.1 Programming the LCD .....	36
3.5.2 Using the LCD Display .....	38
3.5.3 PanaView Display .....	38
3.5.4 Pausing Measurements .....	41
<b>Chapter 4. Specifications</b> .....	<b>43</b>
4.1 Operation and Performance .....	43
4.1.1 Fluid Types .....	43
4.1.2 Pipe Materials .....	43
4.1.3 Pipe Sizes .....	43
4.1.4 Flow Accuracy (Velocity) .....	43
4.1.5 Molecular Weight Accuracy .....	43
4.1.6 Mass Flow Accuracy .....	43
4.1.7 Repeatability .....	43
4.1.8 Rangeability (Overall) .....	43

4.2	Electronics .....	43
4.2.1	Flow Measurement .....	43
4.2.2	Enclosures .....	44
4.2.3	Dimensions (l x d) .....	44
4.2.4	Weight .....	44
4.2.5	Channels .....	44
4.2.6	Display .....	44
4.2.7	Keypad .....	44
4.2.8	Power Supplies .....	44
4.2.9	Power Consumption .....	44
4.2.10	Operating Temperature .....	44
4.2.11	Storage Temperature .....	44
4.2.12	Standard Inputs and Outputs .....	44
4.2.13	Optional Inputs and Outputs .....	44
4.2.14	Digital Interfaces .....	45
4.2.15	European Compliance .....	45
4.3	Wetted Ultrasonic Flow Transducers .....	45
4.3.1	Temperature Range .....	45
4.3.2	Pressure Range .....	45
4.3.3	Materials .....	45
4.3.4	Process Connections .....	45
4.3.5	Area Classifications .....	45
4.4	Insertion Mechanism .....	45
4.4.1	Standard Range .....	45
4.4.2	Extended Velocity Range .....	45
4.5	Preamplifier .....	45
4.5.1	Physical .....	45
4.5.2	Gain .....	46
4.5.3	Temperature Range .....	46
4.5.4	Enclosure .....	46
4.6	Transducer Cables .....	46
4.6.1	Standard (per Transducer pair) .....	46
4.6.2	Optional .....	46
4.7	Options .....	46
4.7.1	PanaView™ PC-Resident Interface Software .....	46
4.7.2	Installation Flowcells .....	46
4.7.3	Pressure and Temperature Transducers .....	46
<b>Appendix A. CE Mark Compliance .....</b>		<b>47</b>
A.1	Introduction .....	47
A.2	Wiring .....	47
<b>Appendix B. Data Records .....</b>		<b>49</b>
B.1	Available Option Cards .....	49
B.2	Option Cards Installed .....	50
B.3	Setup Data .....	51
<b>Appendix C. Measuring P and L Dimensions .....</b>		<b>55</b>
C.1	Introduction .....	55
C.2	Measuring P and L .....	55
<b>Index .....</b>		<b>57</b>
<b>Warranty .....</b>		<b>61</b>



# Chapter 1. Installation

## 1.1 Introduction

To ensure safe and reliable operation of the *XGF868i Ultrasonic Flow Transmitter*, the system must be installed in accordance with the guidelines established by Panametrics engineers. Those guidelines, which are explained in detail in this chapter, include the following specific topics:

- Unpacking the XGF868i system
- Selecting suitable sites for the electronics enclosure, the flowcell and the transducers
- Installing the flowcell and the transducers

**Note:** See the appropriate Transducer Installation Guide for detailed instructions on transducer installation.

- Installing optional temperature and pressure transmitters
- Installing the electronics enclosure
- Wiring the electronics enclosure



**WARNING!** The XGF868i flow transmitter can measure the flow rate of many gases, some of which are potentially hazardous. In such cases, observing the proper safety practices is critical. Be sure to follow all applicable local safety codes and regulations for installing electrical equipment and for working with hazardous gases or flow conditions. Consult company safety personnel or local safety authorities to verify the safety of any procedure or practice.



**Attention European Customers!**  
To meet CE Mark requirements, all cables must be installed as described in Appendix A, *CE Mark Compliance*.

## 1.2 Unpacking

Carefully remove the electronics enclosure, the transducers, and the cables from the shipping containers. Before discarding any of the packing materials, account for all components and documentation listed on the packing slip. The discarding of an important item along with the packing materials is all too common. If anything is missing or damaged, contact the factory immediately for assistance.

## 1.3 Site Considerations

Because the relative location of the flowcell and the electronics enclosure is important, use the guidelines in this section to plan the XGF868i installation.



**WARNING!** Before beginning installation, please refer to *“Installing Panametrics Measurement & Control Ultrasonic Flow Transmitters in a Potentially Hazardous Area”* near the back of this manual.

### 1.3.1 Electronics Enclosure Location

The standard XGF868i electronics enclosure is a powder-coated, cast-aluminum, Type-7/4X explosion-proof enclosure. An optional stainless steel enclosure is available. Typically, the enclosure is mounted as close as possible to the transducers. When choosing a site, make sure the location permits easy access to the electronics enclosure for programming, maintenance and service.

**IMPORTANT:** For compliance with the EU Low Voltage Directive (2006/95/EC), this unit requires an external power disconnect device such as a switch or circuit breaker. The disconnect device must be marked as such, clearly visible, directly accessible, and located within 1.8 m (6 ft) of the unit.

### 1.3.2 Flowcell Location

The pipeline flowcell consists of the flow rate transducers and any pressure and/or temperature transducers employed as part of the flow measurement system. Ideally, choose a section of pipe with unlimited access to the flowcell, such as a long stretch of pipe that is above ground. However, if the flowcell is to be mounted on an underground pipe, dig a pit around the pipe to facilitate installation of the transducers.

### 1.3.3 Transducer Location

For a given fluid and pipe, the accuracy of the XGF868i depends primarily on the location and alignment of the transducers. In addition to accessibility, when planning for transducer location, adhere to the following guidelines:

1. Locate the transducers so that there are at least 20 pipe diameters of straight, undisturbed flow upstream and 10 pipe diameters of straight, undisturbed flow downstream from the measurement point. To ensure undisturbed flow, avoid sources of turbulence in the fluid such as valves, flanges, expansions, elbows and dips or low spots in which condensed liquid may collect.
2. Because condensate or sediment at the bottom of the pipe may cause attenuation of the ultrasonic signal, locate the transducers on the side of a horizontal pipe, when possible. If limited pipe access necessitates top-mounted transducers and the sound beam path includes a reflection, shift the transducers to at least 10° off top dead center. This will minimize the influence of any sediment on the reflected ultrasonic signals.

### 1.3.4 Cable Lengths

Locate the electronics enclosure as close as possible to the flowcell and transducers, preferably directly on the flowcell. However, Panametrics can supply transducer cables up to 1000 ft (300 m) in length for remote location of the electronics enclosure. If longer cables are required, contact Panametrics for assistance.

### 1.3.5 Temperature and Pressure Transmitters

When installing temperature and/or pressure transmitters in the flowcell, locate them downstream of the transducers. These transmitters should be positioned no closer to the XGF868i transducers than 2 pipe diameters and no further away from the transducers than 20 pipe diameters.

### 1.3.6 Transducer Cables

When installing the transducer cables, always observe established standard practices for the installation of electrical cables. Specifically, do not route transducer cables alongside high-amperage AC power lines or any other cables that could cause electrical interference. Also, protect the transducer cables and connections from the weather and from corrosive atmospheres.

**IMPORTANT:** When using non-Panametrics cables to connect the flow transducers to the XGF868i electronics enclosure, the cables must have electrical characteristics identical to the Panametrics cables. Type RG62A/U coaxial cable should be used, and each cable must be the same length (within  $\pm 4$  in.).

All interconnecting cables must comply with IEC/EN 60079-14.

## 1.4 Installing a Flowcell

A flowcell is the section of pipe upon which the transducers are mounted. It can be created either by mounting the transducers on the existing pipeline or by mounting them on a spoolpiece. A spoolpiece is a separately manufactured pipe section, matched to the existing pipe, which contains ports for mounting the transducers. This approach allows the transducers to be aligned and calibrated before inserting the spoolpiece into the pipeline.

*Figure 6 on page 18* shows a typical right-angle mounting bracket for installing the XGF868i electronics enclosure. For detailed instructions on installing the transducers and the spoolpiece, refer to any supplied drawings and to the appropriate *Transducer Installation Guide*.

## 1.5 Installing Temperature and Pressure Transmitters

Optional temperature and pressure transmitters may be installed near the ultrasonic transducer ports as part of the flowcell. Be sure to observe the siting requirements given earlier in this chapter. These transmitters should send a 0/4–20 mA signal to the XGF868i. In turn, the XGF868i must be fitted with a suitable option card to process the signals and to provide the required 24 VDC power to the transmitters. Any desired transmitters or sensors may be used, but they must have an accuracy equal to  $\pm 0.5\%$  of the reading or better.

**Note:** Resistive Thermal Devices (RTDs) are a good choice for measuring the temperature.

Typically, a 1/2" NPT or 3/4" NPT female threaded port is used to mount the transmitters on the flowcell. If the pipeline is insulated, the coupling may need to be extended to provide convenient access. Of course, other types of mounting ports, including flanged ports, may be used for the transmitters.

Figure 1 below shows a typical mounting arrangement for the pressure and temperature transmitters. The temperature sensor should extend into the pipe by 1/4 to 1/2 of the pipe inside diameter.

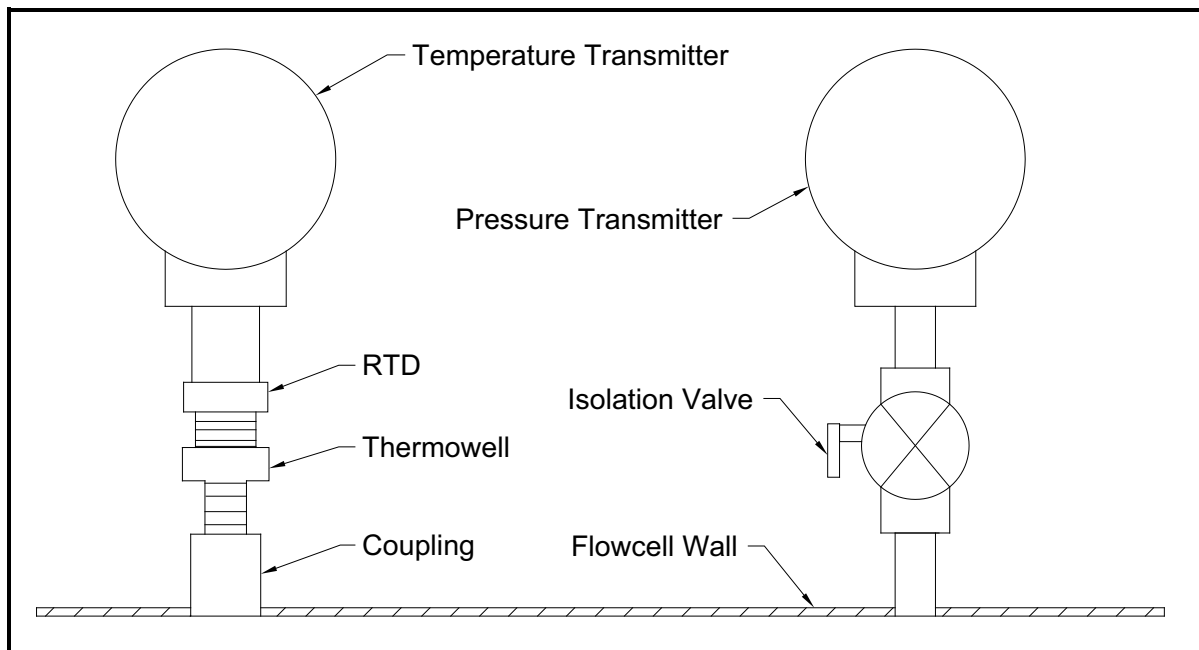

Figure 1: Typical Temperature/Pressure Transmitter Mounting

## 1.6 Mounting the XGF868i Electronics Enclosure

The standard XGF868i electronics package is housed in a Type-4X weather-resistant enclosure suitable for indoor or outdoor use. Refer to *Figure 5 on page 17* for the mounting dimensions and the weight of this enclosure.

The XGF868i electronics enclosure is fitted with a mounting boss that has a single 3/4" NPT-F threaded hole at its center and four 1/4-20 tapped holes at its corners. By using this mounting boss, the electronics enclosure may be mounted by any of the typical techniques shown in *Figure 6 on page 18*.



**WARNING!** Proper grounding of the XGF868i chassis is required to prevent possible electric shock. See *Detail A in Figure 6 on page 18* for the location of the chassis grounding screw.

## 1.7 Making the Electrical Connections

This section contains instructions for making all the necessary electrical connections to the XGF868i flow transmitter. Refer to *Figure 7 on page 19* for a complete wiring diagram.



**WARNING!** Refer to “*Installing Panametrics Ultrasonic Flow Transmitters in a Potentially Hazardous Area*” on page 63 near the rear of this manual for additional installation instructions.

Except for the power connector, all electrical connectors are stored on their terminal blocks during shipment and may be removed from the enclosure for more convenient wiring. Simply, feed the cables through the conduit holes on the side of the enclosure, attach the wires to the appropriate connectors and plug the connectors back onto their terminal blocks.



**WARNING!** To ensure safe and reliable operation of the XGF868i, be sure to install and tighten all cable glands in accordance with the gland manufacturer’s instructions.



**WARNING!** To meet CE Mark requirements, all cables must be installed as described in Appendix A, *CE Mark Compliance*.



**WARNING!** Always disconnect the line power from the XGF868i before removing either the front cover or the rear cover. This is especially important in a hazardous environment.

Refer to *Figure 2* below and prepare the XGF868i for wiring by completing the following steps:

1. Disconnect any existing power line from its source.
2. Loosen the set screw on the rear cover.

3. Place a rod or long screwdriver across the cover in the slots provided, and rotate the cover counterclockwise until it comes free from the enclosure.
4. Install any required cable clamps in the appropriate conduit holes around the side of the enclosure.
5. Note the labels inside the rear cover to assist in wiring the power and option card connections. Also, *Figure 8 on page 20* shows the rear cover option card labels for every available option card configuration.

Proceed to the appropriate section of this chapter to make the desired wiring connections.

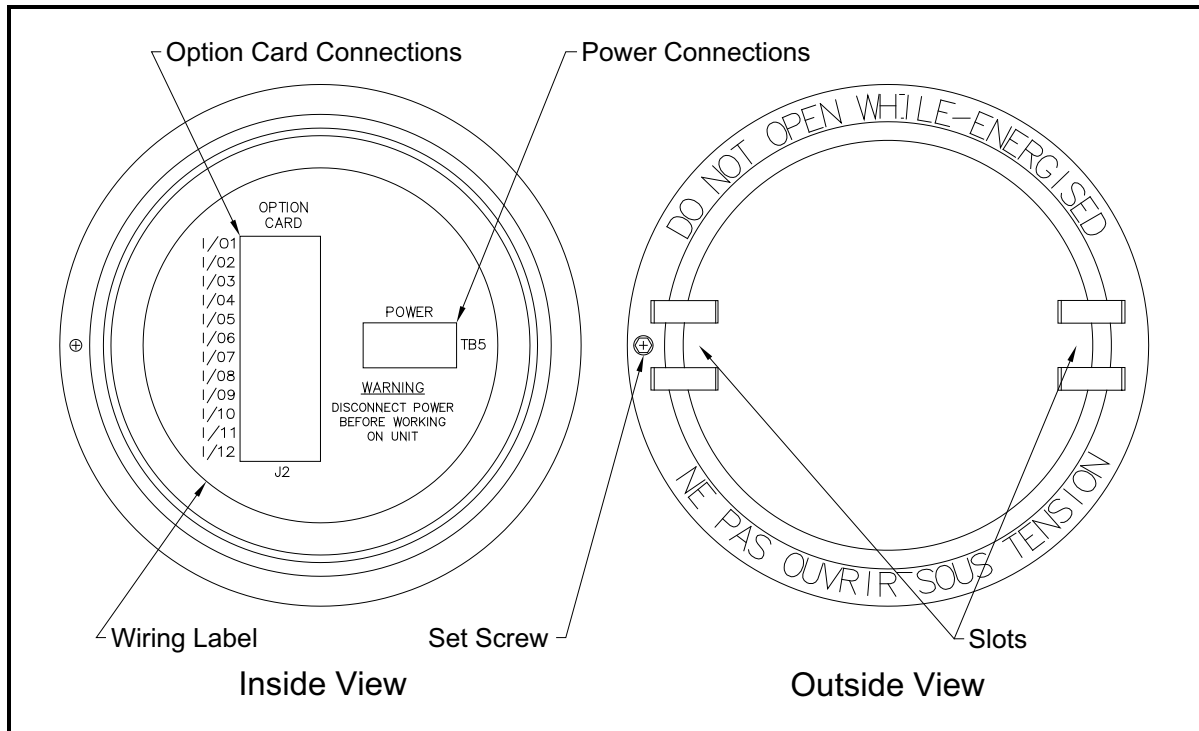

**Figure 2: Rear Cover with Connection Labels**

### 1.7.1 Wiring the Line Power

The XGF868i may be ordered for operation with power inputs of 100–120 VAC, 220–240 VAC, or 12–28 VDC. The label on the side of the electronics enclosure lists the required line voltage and the power rating for the unit. Be sure to connect the meter only to the specified line voltage. The fuse size is listed in *Table 1* below.

**Table 1: Line Voltages and Fuse Ratings**

Line Voltage	Fuse Rating
85–250 VAC	Not field-replaceable (contact Panametrics)
12–28 VDC	2.0 A, Slow-Blow

**IMPORTANT:** For compliance with the EU Low Voltage Directive (2006/95/EC), this unit requires an external power disconnect device such as a switch or circuit breaker. The disconnect device must be marked as such, clearly visible, directly accessible, and located within 1.8 m (6 ft) of the unit.

**Note:** Only use Class 2 Rated Power supply for line power connection to DC instrument.

Refer to *Figure 7* on *page 19* to locate terminal block TB5 and connect the line power as follows:



**HIGH VOLTAGE!** Improper connection of the line power leads or connecting the meter to the incorrect line voltage may damage the unit. It may also result in hazardous voltages at the flowcell and associated piping as well as within the electronics enclosure.

1. Prepare the line power leads by trimming the line and neutral AC power leads (or the positive and negative DC power leads) to a length 0.5 in. (1 cm) shorter than the ground lead. This ensures that the ground lead is the last to detach if the power cable is forcibly disconnected from the meter.
2. Install a suitable cable clamp in the conduit hole indicated in *Figure 7* on *page 19*. If possible, avoid using the other conduit holes for this purpose, to minimize any interference in the circuitry from the AC power line.



**WARNING!** To meet CE Mark requirements, all cables must be installed as described in *Appendix A, CE Mark Compliance*.

3. Strip 1/4 in. of insulation from the end of each of the three power line leads.
4. Route the cable through the conduit hole and connect the line power leads to terminal block TB5, using the pin number assignments shown in *Figure 7* on *page 19*.
5. Leaving a bit of slack, secure the power line with the cable clamp.



**WARNING!** Make sure that both covers with the o-ring seals are installed and the set screws are tightened before applying power to the unit in a hazardous environment.



**CAUTION!** The transducers must be properly wired before applying power to the meter.

## 1.7.2 Wiring the Transducers and Preamplifiers

Before wiring the XGF868i transducers and preamplifiers, complete the following steps:

- Disconnect the main power from the electronics enclosure
- Remove the rear cover and install all required cable clamps

The *electronics enclosure* may be located either directly on the flowcell (*local*) or some distance away from the flowcell (*remote*). The *preamplifiers* may be located either in the transducer junction boxes (*local*) or some distance away from the transducers in their own separate enclosures (*remote*). Based on the specific configuration of your system, proceed to one of the following sections for detailed instructions:

- Local or Remote electronics enclosure with **Local preamplifiers** (see Section 1.7.2.1 on page 8)
- Local or Remote electronics enclosure with **Remote preamplifiers** (see Section 1.7.2.2 on page 9)

### 1.7.2.1 Local or Remote Electronics Enclosure with Local Preamplifiers



**WARNING!** Before connecting the transducers, take them to a safe area and discharge any static buildup by shorting the center conductor of the transducer cables to the metal shield on the cable connector.

**IMPORTANT:** The cable lengths for a given pair of transducers, including the preamplifier-to-electronics enclosure cables, must be equal to within  $\pm 4$  in. (10 cm) of each other.

For an XGF868i system configured with either a local or remote electronics enclosure and local preamplifiers, wire the transducers and preamplifiers as follows:

1. The local preamplifier must be installed in the junction box on the end of the transducer. Connect the BNC cable with the mating connector from the preamplifier to the transducer BNC connector.
2. Locate the two CH1 preamplifier-to-electronics enclosure cables and connect one to each of the two CH1 preamplifiers in the junction boxes, using the remaining preamplifier connections. Then, feed the free ends of the cables through the selected conduit holes in the electronics enclosure.
3. See *Figure 7 on page 19* for the location (**J3**) of the connections for the Channel 1 transducers in the electronics enclosure. Then, refer to *Figure 10* to wire the transducer to preamplifier and preamplifier to electronics enclosure connections.

**Note:** The RED cable leads are the SIG(+) leads and the BLACK cable leads are the RTN(-) leads.



**Attention European Customers!**  
To meet CE Mark requirements, all cables must be installed as described in Appendix A, CE Mark Compliance.

4. For a 2-Channel XGF868i, repeat steps 1-3 to connect the CH2 transducers to terminal block **J4** in the electronics enclosure. Note that it is not required that both channels of a 2-channel unit be connected.
5. If wiring of the system has been completed, reinstall the rear cover and o-ring on the electronics enclosure and tighten the set screw.

**Note:** A channel must be activated in the Channel Menu before it can begin taking measurements. See Chapter 2, Initial Setup, for instructions.



### 1.7.2.2 Local or Remote Electronics Enclosure with Remote Preamplifiers



**WARNING!** Before connecting the transducers, take them to a safe area and discharge any static buildup by shorting the center conductor of the transducer cables to the metal shield on the cable connector.

**IMPORTANT:** The cable lengths for a given pair of transducers, including the preamplifier-to-electronics enclosure cables, must be equal to within  $\pm 4$  in. (10 cm) of each other.

**Note:** A dual preamplifier is typically used in these installations, and you must note the labeled upstream and downstream connections on the preamplifier. Be sure to connect the upstream transducer to the upstream connection on the preamplifier and in the XGF868i electronics enclosure. Follow the same procedure for the downstream connections.

The remote preamplifier (PRE868) uses a transformer (p/n 705-603) which connected to the "XDCR" BNC connector on the preamplifier (see Figure 9 on page 21).

For an XGF868i system configured with either a local or remote electronics enclosure and a dual remote preamplifier, wire the transducers and preamplifier as follows:

1. Refer to *Figure 9 on page 21* and use the pair of coaxial cables with BNC to BNC connectors supplied by Panametrics (or equivalent cables) to connect both **CH1** transducers to the dual preamplifier, using the connections on the transformer.



**CAUTION!** As part of maintaining the FM/CSA environmental rating (TYPE 4) on the remote preamplifier, thread sealant is required on all conduit entries.

2. If an optional lightning protector is installed, connect it between the preamplifier and the electronics enclosure. Locate the device near the electronics enclosure and install it according to the supplied wiring documentation for the device.
3. See *Figure 7 on page 19* for the location (**J3**) of the connections for the Channel 1 transducers in the electronics enclosure. Using the supplied coaxial cables with BNC to flying lead connectors (or equivalent cables), route the cables through one of the conduit holes in the electronics enclosure and connect the preamplifier to terminal block **J3**. Secure the cables with the cable clamp.

**Note:** The RED cable leads are the SIG(+) leads and the BLACK cable leads are the RTN(-) leads..



**Attention European Customers!**

To meet CE Mark requirements, all cables must be installed as described in Appendix A, CE Mark Compliance.

4. For a 2-Channel XGF868i, repeat steps 1-3 to connect the CH2 transducers to terminal block **J4** in the electronics enclosure. Note that it is not required that both channels of a 2-channel unit be connected.
5. If wiring of the system has been completed, reinstall the rear cover and o-ring on the electronics enclosure and tighten the set screw.

**Note:** A channel must be activated in the Channel Menu before it can begin taking measurements. See Chapter 2, Initial Setup, for instructions.

### 1.7.3 Wiring Std 0/4-20 mA Analog Outputs

The standard configuration of the XGF868i flow transmitter includes two isolated 0/4-20 mA analog outputs (designated as outputs 1 and 2). Connections to these outputs may be made with standard twisted-pair wiring, but the current loop impedance for these circuits must not exceed 600 ohms.

To wire the analog outputs, complete the following steps:

1. Disconnect the main power and remove the rear cover.
2. Install the required cable clamp in the chosen conduit hole on the side of the electronics enclosure.
3. Refer to *Figure 7 on page 19* for the location of terminal block **J1** and wire the analog outputs as shown. Secure the cable clamp.

**Note:** *Analog outputs 1 and 2 in the wiring diagram correspond to analog outputs A and B in Slot 0 in the XGF868i software.*



**WARNING!** To meet CE Mark requirements, all cables must be installed as described in Appendix A, CE Mark Compliance.

4. If wiring of the unit has been completed, reinstall the rear cover on the enclosure and tighten the set screw.



**WARNING!** Make sure that both covers with the o-ring seals are installed and the set screws are tightened before applying power to the unit in a hazardous environment.

**Note:** *Prior to use, the analog outputs must be set up and calibrated. See Chapter 1, Calibration, of the Service Manual for detailed instructions.*

### 1.7.4 Wiring the Serial Port

The XGF868i flowmeter is equipped with an RS232 serial interface. The serial port is used to transmit stored data and displayed readings to a personal computer by connecting the meter's serial interface to the serial port of the PC. In addition, the XGF868i can receive and execute remote commands, using the *Instrument Data Manager* or *PanaView* software via this link.

For more information on serial communications refer to your *EIA-RS Serial Communications* manual (916-054). Proceed to the appropriate sub-section for wiring instructions.



**WARNING!** To meet CE Mark requirements, all cables must be installed as described in Appendix A, CE Mark Compliance.

### 1.7.4.1 Wiring the RS232 Interface

Use the serial port to connect the XGF868i flow transmitter to a printer, an ANSI terminal or a personal computer. The RS232 interface is wired as Data Terminal Equipment (DTE). *Table 2* below lists the standard cables available from the factory for this purpose.

**Table 2: Panametrics Serial Cables**

Part Number	PC Connector	XGF868i Connector
704-659	DB-25 Male	Flying Leads (5)
704-660	DB-9 Male	Flying Leads (5)
704-661	DB-25 Female	Flying Leads (5)
704-662	DB-9 Female	Flying Leads (5)

Each of the cables listed in the table above is available in several standard lengths. However, a user-supplied cable may be used, if preferred. In either case, wire the XGF868i end of the serial cable in accordance with the pin designations listed in *Table 3*.

Refer to *Figure 7* on page 19 to complete the following steps:



**HIGH VOLTAGE!** Dangerous voltages exist within the electronics enclosure. Do not attempt to wire the unit until the main power has been disconnected.

1. Disconnect the main power and remove the rear cover.



**WARNING!** The XGF868i must be moved to a safe environment before removing either cover

2. Install the required cable clamp in the chosen conduit hole on the side of the electronics enclosure.
3. Use the information in *Table 3* below to construct a suitable cable for connecting the XGF868i to the external device. If desired, an appropriate cable may be purchased from Panametrics.

**Table 3: RS232 Connection to DCE or DTE Device**

J1 Pin #	Signal Description	DCE DB25 Pin #	DCE DB9 Pin #	DTE DB25 Pin #	DTE DB9 Pin #
5	DTR (Data Terminal Ready)	20	4	20	4
6	CTS (Clear to Send)	4	7	5	8
7	COM (Ground)	7	5	7	5
8	RX (Receive)	2	3	3	2
9	TX (Transmit)	3	2	2	3

4. Feed the cable's flying leads through the conduit hole and wire it to terminal block J1. Connect the other end of the cable to the external serial device and secure the cable clamp.

After the wiring has been completed, consult the *User's Manual* for the external device to configure it for use with the XGF868i.

## 1.7.5 Wiring the Option Cards

The XGF868i can accommodate one option card in **Slot 1** and one option card in **Slot 2**. The following option card functions are available only in the combinations listed in *Table 13*:

- Analog Inputs (Slot 1)
- Totalizer/Frequency Outputs (Slot 1)
- RTD Inputs (Slot 1)
- Analog Outputs (Slot 1)
- MODBUS Communications (Slot 2)
- MODBUS/TCP Communications (Slot 2)
- Ethernet (Slot 2)
- Foundation Fieldbus (Slot 2)
- Data Logging (Slot 2) - *no wiring required*

Wiring any option card installed in Slot 1 requires completion of the following general steps:

### 1.7.5.1 Preparing for Wiring

1. Disconnect the main power and remove the rear cover.
2. Install a cable clamp in the chosen conduit hole on the side of the electronics enclosure and feed a standard twisted-pair cable through this conduit hole.
3. Locate the 12-pin terminal block (**J2**) in *Figure 7 on page 19* and wire the option card as indicated on the label inside the rear cover (see *Figure 2 on page 6* and *Figure 8 on page 20*). Secure the cable clamp.

**IMPORTANT:** Because of the attached wiring label, all rear covers must remain with their original meters.



**WARNING!** To meet CE Mark requirements, all cables must be installed as described in Appendix A, *CE Mark Compliance*.

4. If wiring of the unit has been completed, reinstall the rear cover on the enclosure and tighten the set screw.

**Note:** *Prior to use, the option card must be set up and calibrated. See Chapter 1, Programming Site Data, in the Programming Manual and Chapter 1, Calibration, in the Service Manual for detailed instructions.*

For more specific instructions on particular option cards, proceed to the appropriate section(s) that follow.

### 1.7.5.2 Wiring a 0/4-20 mA Analog Inputs Option Card

To calculate the standard flow rates, the XGF868i requires accurate *temperature* and *pressure data* from the measurement site. Transmitters installed in the flowcell can provide this information via an optional 0/4-20 mA analog inputs option card. This option card includes two or four isolated 0/4-20 mA analog inputs (designated as A, B, C and D), each of which includes a 24 VDC power supply for loop-powered transmitters. Either input may be used to process the temperature signal, while the other input is used to process the pressure signal.

**Note:** To properly enter programming data into the meter, it is necessary to know which input is assigned to which process parameter. This information should be entered in Appendix B, Data Records.

The analog inputs, which have an impedance of 118 ohms, should be connected with standard twisted-pair wiring. Power to the transmitters may be supplied either by the integral 24 VDC power supply on the analog input option card or by an external power supply. Figure 3 below shows typical wiring diagrams, with and without an external power supply, for one of the analog inputs.

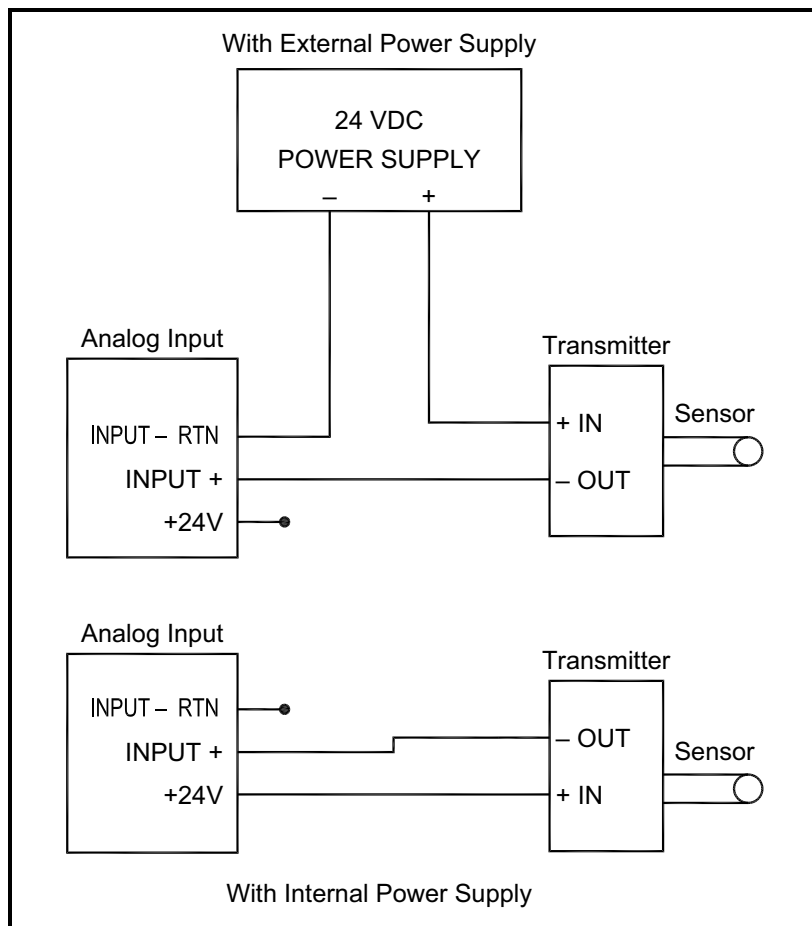

**Figure 3: Analog Input Wiring Diagram**

Before making any connections, complete the steps in *Preparing for Wiring* on page 12. Wire the analog inputs as shown on the label in the rear cover (see *Figure 8* on page 20).

**Note:** The analog inputs option card can be calibrated with the XGF868i built-in analog outputs. However, be certain that the analog outputs have been calibrated first. See Chapter 1, Calibration, in the Service Manual for the appropriate procedures.

### 1.7.5.3 Wiring a Totalizer/Frequency Outputs Option Card

Each totalizer/frequency outputs option card provides two or four outputs (designated as A, B, C, and D) that can be used as either totalizer or frequency outputs.

Before making any connections, complete the steps in *Preparing for Wiring* on page 12. Then, wire this option card in accordance with the connections shown on the label in the rear cover (see *Figure 2* on page 6 and *Figure 8* on page 20). *Figure 4* below shows sample wiring diagrams of a totalizer output circuit and a frequency output circuit. Refer to See “*Optional Inputs and Outputs*” on page 44. for load and voltage requirements.

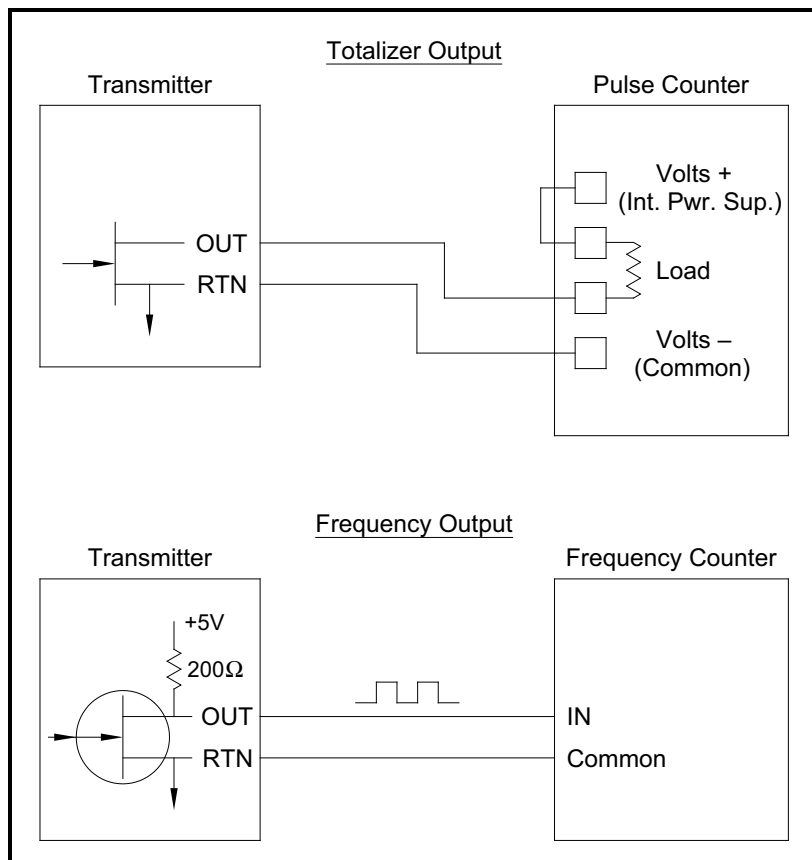

**Figure 4: Totalizer/Frequency Outputs Wiring**

### 1.7.5.4 Wiring an RTD Inputs Option Card

The XGF868i RTD (Resistance Temperature Device) inputs option card provides two or four direct RTD inputs (designated as A, B, C and D). Each RTD input requires three wires, and should be connected as shown on the label in the rear cover (see *Figure 2* on page 6 and *Figure 8* on page 20).

**Note:** Before making any connections, complete the steps in *Preparing for Wiring* on page 12.

### 1.7.5.5 Wiring a 0/4–20 mA Analog Outputs Option Card

The analog outputs option card includes two isolated 0/4–20 mA outputs (designated as A and B). Connections to these outputs may be made with standard twisted-pair wiring, but the total current loop impedance for these circuits must not exceed 1000 ohms.

Before making any connections, complete the steps in *Preparing for Wiring* on page 12. Then, wire this option card with the connections shown on the label in the rear cover (see *Figure 2* on page 6 and *Figure 8* on page 20).

### 1.7.5.6 A Specific Example

To illustrate the procedures described in the previous sections for wiring the option cards, a specific example may prove helpful. Assume that an XGF868i is equipped with an option card numbered 703-1223-08. *Table 13* in Appendix B, *Data Records*, indicates that this option card includes two analog current inputs and two standard alarm relays.

### 1.7.5.7 Wiring the MODBUS/TCP Interface

Customers can also use a modified XGF868i that provides a MODBUS/TCP interface to communicate to an internal network. An optional MODBUS/TCP card with a unique MAC (IP) address (installed only in slot 2) includes an RJ45 connector. To connect the MODBUS/TCP-enabled XGF868i to the network, insert the jack of an RJ45 cable into the RJ45 connector, route the cable through one of the conduit holes using an appropriate cable clamp, and wire the other end of the cable to the Ethernet network according to the manufacturer's instructions (see Figure 11).

**Note:** The MAC address for a specific XGF868i is included with customer documentation. For more information on setting up the MAC address, refer to Chapter 6 of the Programming Manual.

### 1.7.5.8 Wiring the Ethernet Interface

A modified XGF868i can use the Ethernet interface to communicate to a local area network. An optional Ethernet card with a unique MAC (IP) address (installed only in slot 2) includes an RJ45 connector. To connect the Ethernet-enabled XGF868i to the network, insert the jack of an RJ45 cable into the RJ45 connector, route the cable through one of the conduit holes using an appropriate cable clamp, and wire the other end of the cable to the Ethernet network according to the manufacturer's instructions. An external connection is required between the Ethernet option card and the XGF868i RS232 connector, as shown in Table 4 below and Figure 11.

**Note:** The MAC address for a specific XGF868i is included with the customer documentation. For more information on setting up the MAC address, refer to Appendix C of the Programming Manual.

**Table 4: RS232 to Ethernet Interconnections**

RS232 Terminal Block on Rear Board	TB1 Terminal Block on Ethernet Card
TX	Pin 1
RX	Pin 2
COM	Pin 3

### 1.7.5.9 Wiring the Foundation Fieldbus Interface

To connect the Foundation Fieldbus interface to the XGF868i, make the network connections at J8, pins 1 and 2, as shown in drawing Y of Figure 11. As an option, you can connect a shield to J8 pin 3, depending on the network wiring.

No connections are made to J9 under normal operation. If you need to reset the network board to factory defaults:

1. Connect a jumper between J9 pin 2 and J9 pin 3.
2. Power cycle (i.e., turn off and on) the XGF868i.
3. Ten seconds after the power has been restored to the XGF868i, remove the jumper to return the network board to normal operation.



**WARNING!** Make sure that both covers with the o-ring seals are installed and the set screws are tightened before applying power to the unit in a hazardous environment.

[no content intended for this page]



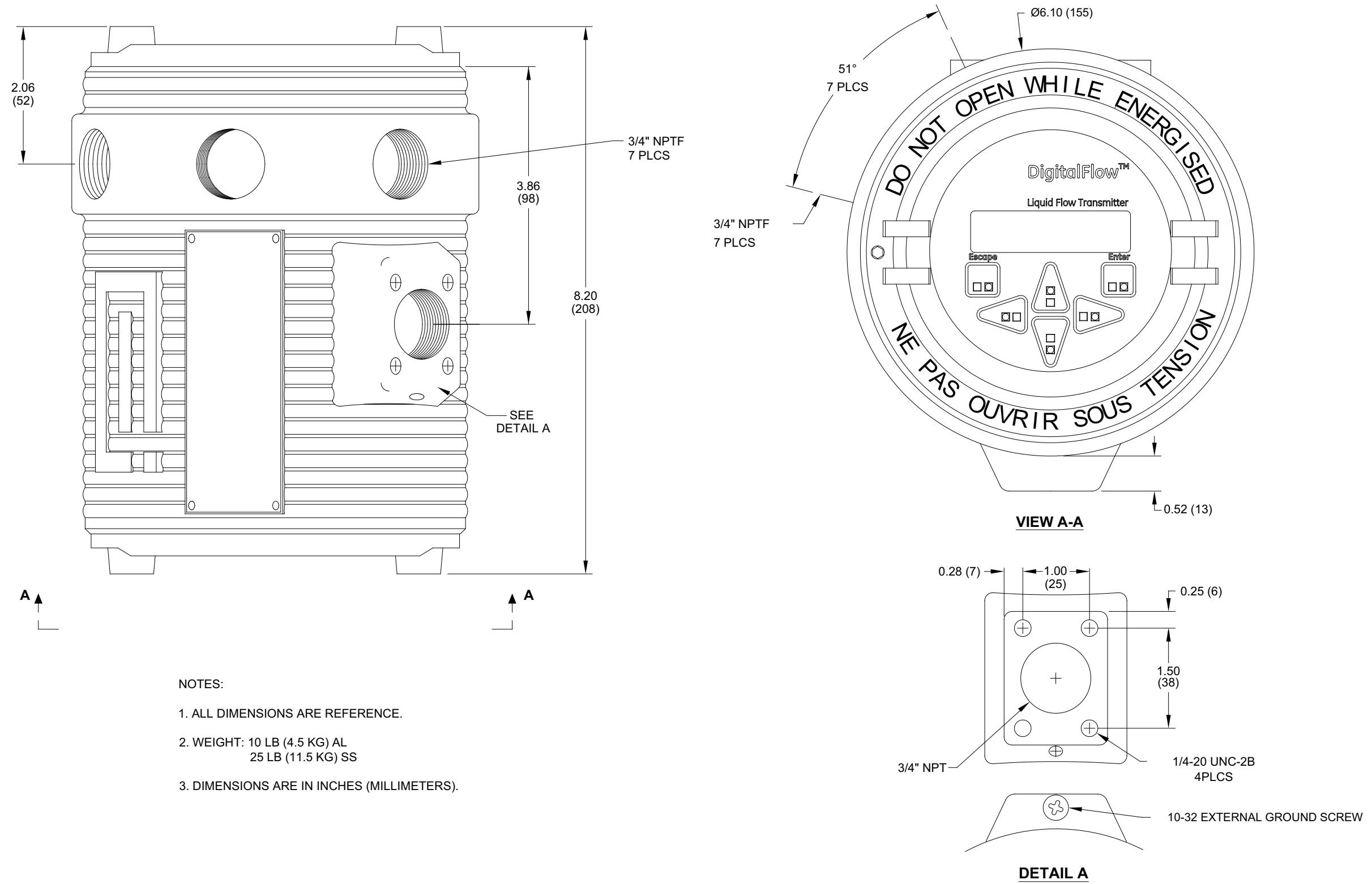

Figure 5: Outline and Installation - Electronics Enclosure (ref. dwg #712-1318)

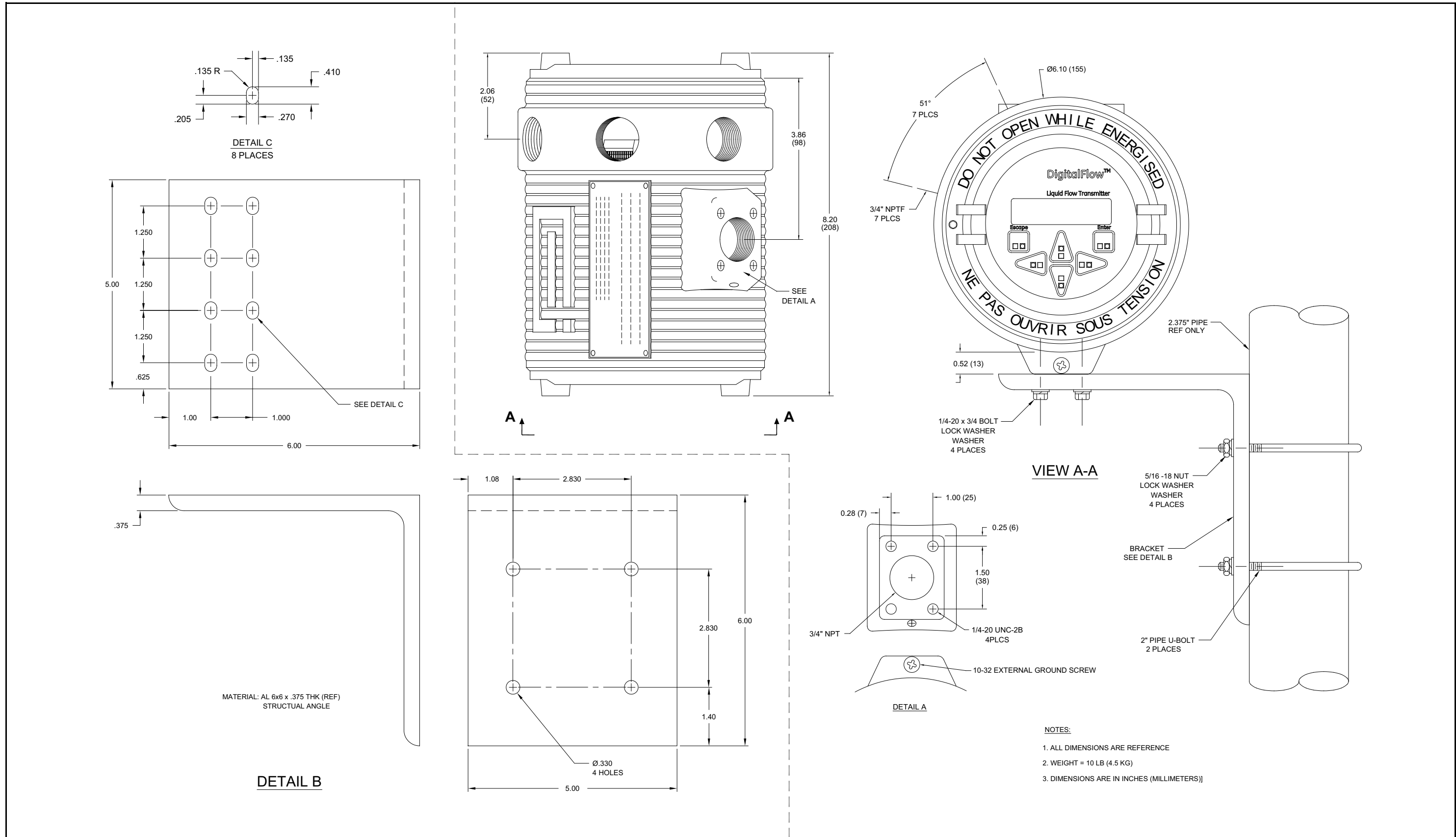

Figure 6: Right Angle Mounting Bracket - Electronics Enclosure (ref. dwg #712-1317)

**NOTE:** For compliance with the EU Low Voltage Directive, this unit requires an external power disconnect device such as a switch or circuit breaker. The disconnect device must be marked as such, clearly visible, directly accessible and located within 1.8 m (6 ft) of the unit.

J2 - INPUT/OUTPUT CONNECTIONS*												
Pin #	1	2	3	4	5	6	7	8	9	10	11	12
Designation	I/O1	I/O2	I/O3	I/O4	I/O5	I/O6	I/O7	I/O8	I/O9	I/O10	I/O11	I/O12
Description	*See the wiring label inside the rear cover and Figure 9.											

J5 - MODBUS CONNECTION		
Pin #	Designation	Description
1	+	MODBUS +
2	-	MODBUS -
3	N/C	N/C

J1 - RS232/ 4-20 OUTPUT		
Pin #	Designation	Description
1	TX	Transmit / +
2	RX	Receive / -
3	COM (SHLD)	Ground
4	CTS	Clear To Send
5	DTR	Data Terminal Ready
6	AOUT B-	4-20 Output 2 RTN
7	AOUT B+	4-20 Output 2 SIG
8	AOUT A-	4-20 Output 1 RTN
9	AOUT A+	4-20 Output 1 SIG

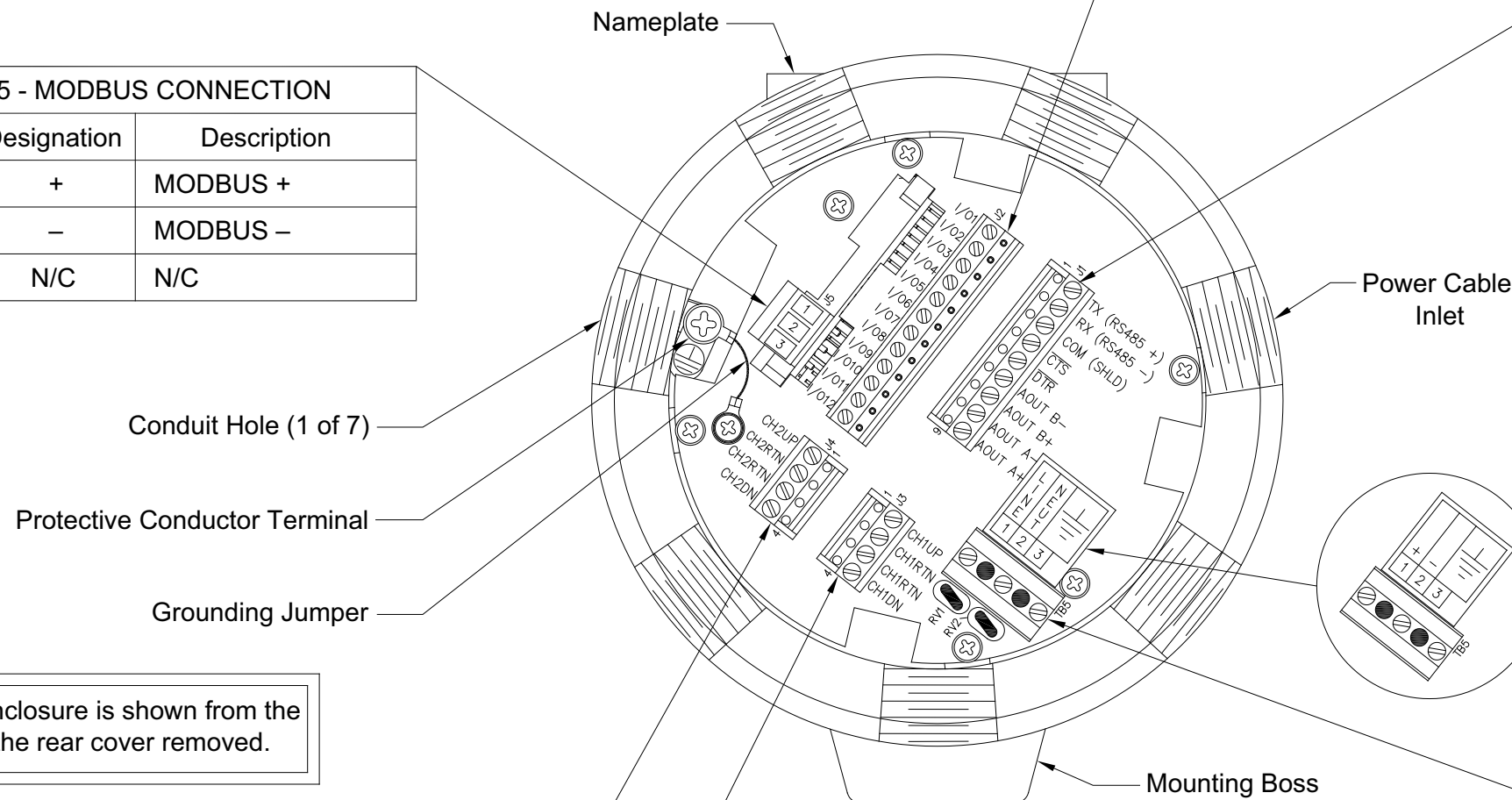

**NOTE:** Enclosure is shown from the rear with the rear cover removed.

J4 - CH2 TRANSDUCER CONNECTION (optional)		
Pin #	Designation	Description
1	CH2UP	Upstream Transducer SIG(+)
2	CH2RTN	Upstream Transducer Analog RTN(-)
3	CH2RTN	Downstream Transducer Analog RTN(-)
4	CH2DN	Downstream Transducer SIG(+)

J3 - CH1 TRANSDUCER CONNECTION		
Pin #	Designation	Description
1	CH1UP	Upstream Transducer SIG(+)
2	CH1RTN	Upstream Transducer Analog RTN(-)
3	CH1RTN	Downstream Transducer Analog RTN(-)
4	CH1DN	Downstream Transducer SIG(+)

DC POWER INPUT	
Pin #	Description
1	Line Positive
2	Line Negative
3	No Connection

AC POWER INPUT	
Pin #	Description
1	Line Power
2	Line Neutral
3	Earth Ground

Figure 7: Wiring Diagram - Electronics Enclosure

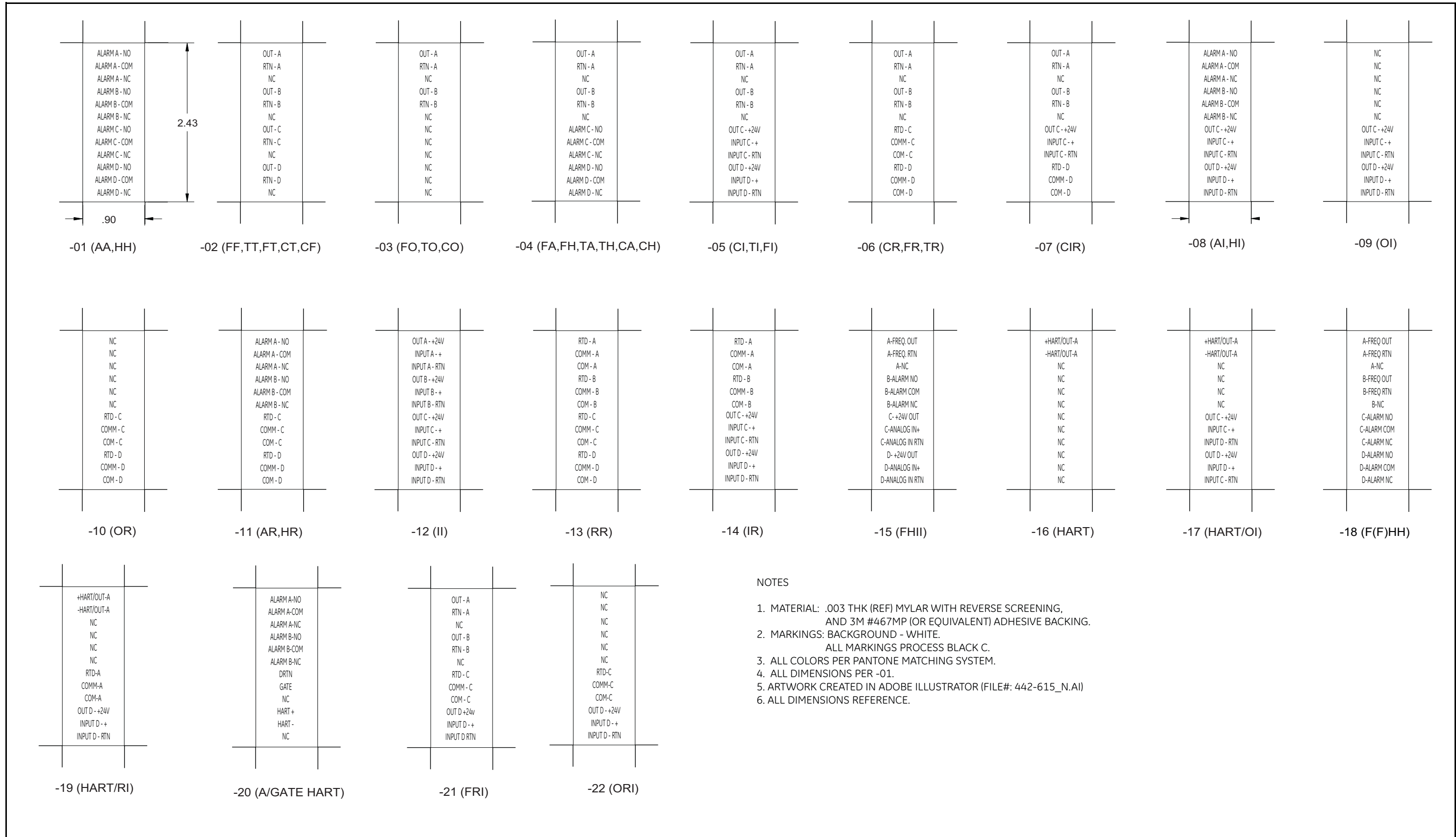

NOTES

1. MATERIAL: .003 THK (REF) MYLAR WITH REVERSE SCREENING, AND 3M #467MP (OR EQUIVALENT) ADHESIVE BACKING.
2. MARKINGS: BACKGROUND - WHITE. ALL MARKINGS PROCESS BLACK C.
3. ALL COLORS PER PANTONE MATCHING SYSTEM.
4. ALL DIMENSIONS PER -01.
5. ARTWORK CREATED IN ADOBE ILLUSTRATOR (FILE#: 442-615\_N.AI)
6. ALL DIMENSIONS REFERENCE.

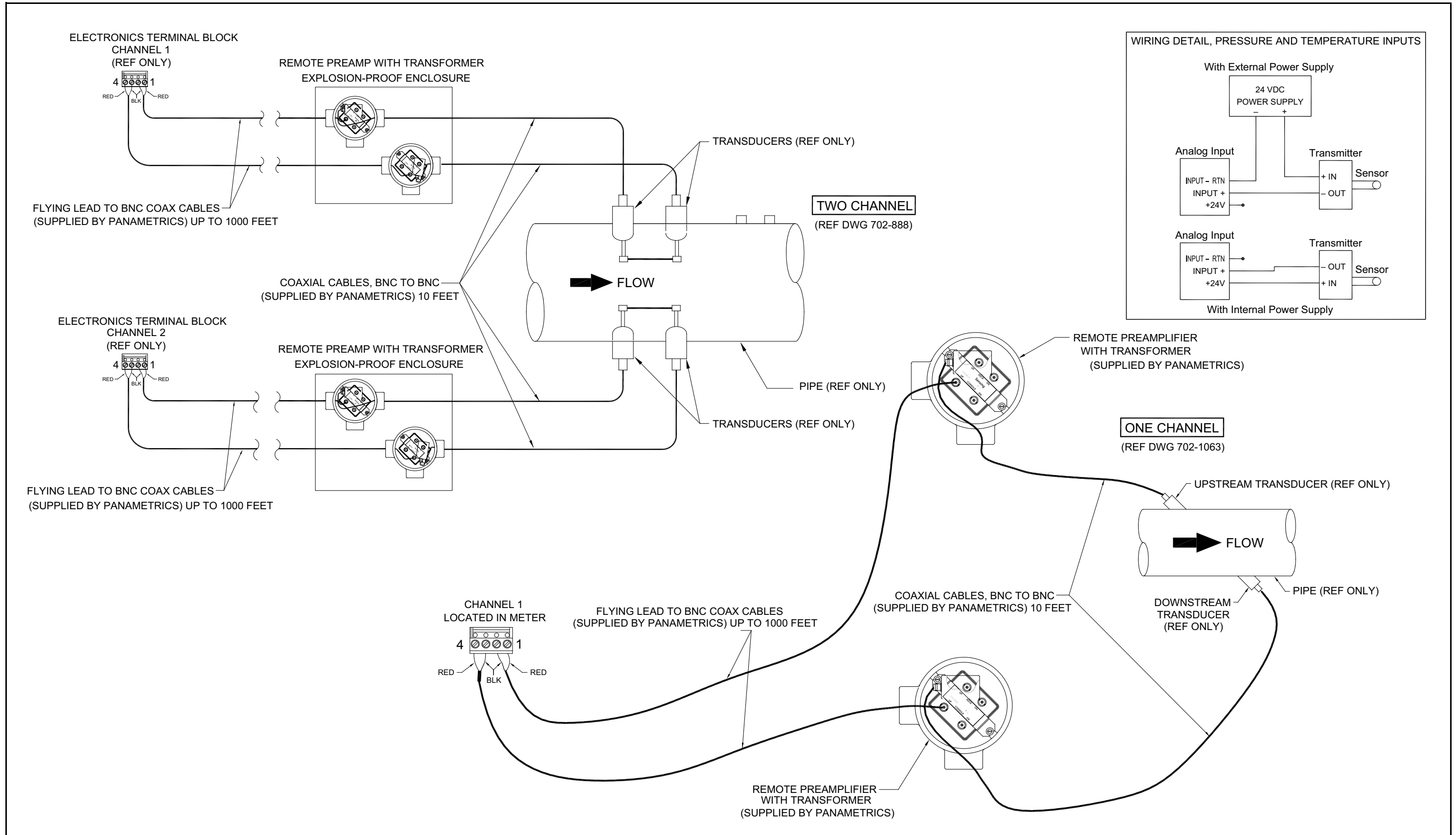

Figure 9: Wiring Diagram - Transducers with Remote Preamplifier (PRE868) and Transformer

[no content intended for this page]

## Chapter 2. Initial Setup

### 2.1 Introduction

This chapter provides instructions for programming the minimum amount of data required to place the XGF868i flowmeter into operation. Before the XGF868i can begin taking measurements and displaying valid data, the current system and pipe parameters must be entered. In addition, a 2-Channel meter requires that each channel be activated prior to use. Additional programming options provide access to the more advanced features of the XGF868i, but this information is not required to begin taking measurements.

Refer to the *Programming Manual* for information on programming all other features. Be sure to record all programming data in Appendix B, *Data Records*.

As a guide in following the programming instructions in this chapter, the relevant portions of the XGF868i menu map have been reproduced in *Figure 11 on page 31*.

### 2.2 Programming Methods

**Note:** See the *Programming Manual* for information on those User Program features not covered in this chapter.

You can program the XGF868i via either the keypad on the lower part of the glass enclosure, or **PanaView™**, a Panametrics PC-based, non-resident software program that communicates with the XGF868i via its RS232 serial port. PanaView supplements basic XGF868i functions with several additional capabilities. With PanaView, you can:

- Load and save site file data
- Create and save graph and log files
- Display text output and graphs of live measurement data
- Create custom templates for displaying text, graph and log data
- Interface with multiple Panametrics instruments.

This chapter focuses on programming via the keypad. For information on programming the XGF868i via PanaView, refer to Appendix C of the *Programming Manual*.

## 2.3 The XGF868i Keypad

### Keypad Program

Along with the 2-line, 16-character LCD, the XGF868i includes a 6-key magnetic keypad. The decal cutout for each key contains a hall effect sensor, pushbutton switch and visible red LED. The magnetic wand used to activate a magnetic key is found attached to the meter chassis below the front panel. An operator activates the key by pressing the magnetic wand up to the glass lid over the desired key. The LED will light indicating a successful key press.

**Note:** *The pushbutton switch will also act as a key press but is done with the glass lid open. Do not use the pushbutton switch in a hazardous area where the lid needs to be installed.*

Use the magnetic keypad to navigate through the user program. The menu map may be followed in sequence, or the four arrow keys may be used to scroll through the prompt screens. Figure 10 shows the front of the XGF868i, with magnetic keypad and magnetic wand.

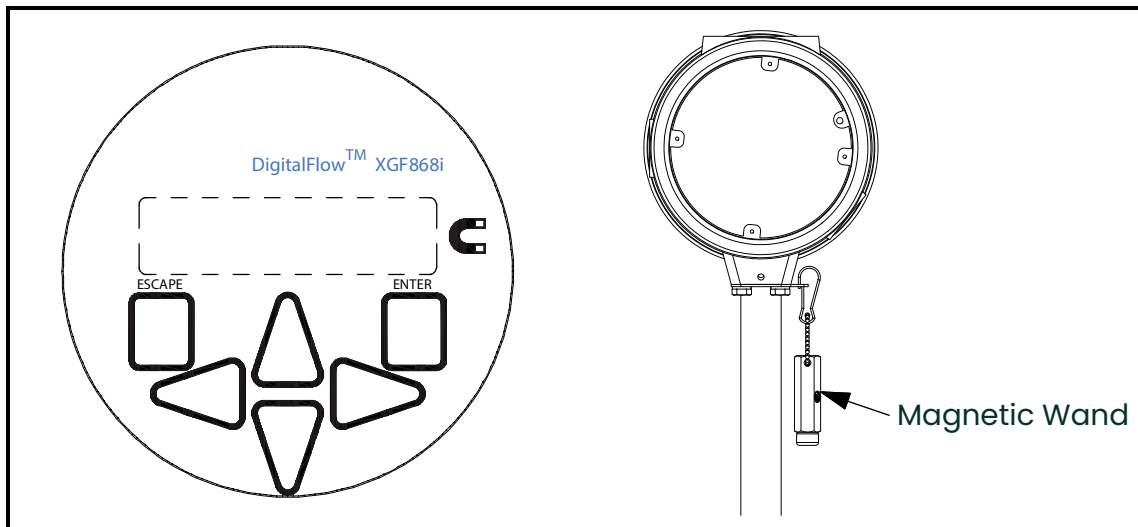

Figure 10: XGF868i Magnetic Keypad and Wand

**IMPORTANT:** The XGF868i keypad enables programming of the instrument through the glass faceplate without removing the cover. Thus, all programming procedures may be performed while the unit is installed in a hazardous area.

Six keys on the keypad enable users to program the XGF868i:

- [Enter] - confirms choice of a specific option and data entry within the option
- [Escape] - allows users to exit from a specific option without entering unconfirmed data
- [△] and [▽] - enable users to view a specific measurement in the Key display setting or to scroll through a list of options (letters and numbers 0-9 as well as the negative sign and decimal point) in a menu
- [◀] and [▶] - enable users to scroll to a specific option, among choices in an option, or to a character in a text entry.

When you power up the XGF868i, the display first shows the model and software version:

Panametrics  
 XGF868i Y4DF.STD



The meter then starts to display measured parameters.

CH1	VEL	E1
	10.00	Ft/s

To enter the *Keypad Program*, press the [Escape] key, followed by the [Enter] key, and the [Escape] key again. Each successive key must be entered within 10 seconds of the prior key.

As a guide in following the programming instructions in this chapter, the relevant portions of the Model XGF868i menu map have been reproduced in *Figure 11 on page 31*. Proceed to the following sections to enter data in the Channel or GLOBL menus.

**IMPORTANT:** If the keypad has not been pressed for 10 minutes, the XGF868i exits the Keypad Program and returns to displaying measurements. The meter retains any configuration changes that were confirmed with the [Enter] key, and restarts as if the operator had completed the programming cycle.

## 2.4 Entering Data in the GLOBL Menu

To begin programming your meter, you must select the system units from the **GLOBL** menu as discussed below. Refer to *Figure 11 on page 31* and remember to record all programming data in Appendix B, *Data Records*.

**Note:** Refer to the Programming Manual for information on the other submenus in the GLOBL menu.

### 2.4.1 Entering Global System Data

The GLOBL-SYSTM submenu is used to enter several general system parameters (e.g., English or metric units). For units with 2 channels, this menu is also used to compute parameters such as the sum, difference or average of the channel 1 and channel 2 signals. When calculating the **SUM**, **DIF** or **AVE** readouts, data from the **GLOBL-SYSTM** submenu is used. Any conflicting data entered in the **CHANNEL-SYSTM** submenu is overridden.

1. In the *Keypad Program*, scroll to PROG and press [Enter].
2. In the PROG menu, scroll to GLOBL and press [Enter].
3. In the Global PROGRAM menu, scroll to SYSTM and press [Enter].
4. Scroll to the desired *System Units* selection (either metric or English) and press [Enter]. The XGF868i will display all parameters and measurements in the designated units.
5. Scroll to the desired *Pressure Units* selection (absolute or gauge) and press [Enter].
6. Do one of the following:
  - If PS1a (absolute) was selected, proceed to Step 7.
  - If PS1g (gauge) was selected, enter the desired atmospheric pressure, press [Enter] and proceed to Step 7.
7. Do one of the following:
  - For a single-channel XGF868i, the program returns to the Global PROGRAM menu.
  - For a 2-channel meter, proceed to the next page.

### 2.4.1.1 Selecting Volumetric Units

1. Scroll to the desired *Volumetric Units* for the flow rate display and press [Enter]. *Table 5* below lists the available volumetric units.

**Table 5: Available Volumetric/Totalizer Units**

English	Metric
ACF = Actual Cubic Feet	ACM = Actual Cubic Meters
KACF = Thousands of ACF	KACM = Thousands of ACM
MMACF = Millions of ACF	MMACM = Millions of ACM
SCF = Standard Cubic Feet	SCM = Standard Cubic Meters
KSCF = Thousands of SCF	KSCM = Thousands of SCM
MMSCF = Millions of SCF	MMSCM = Millions of SCM

2. Scroll to the desired unit of *Volumetric Time* (from seconds to days), and press [Enter].
3. Scroll to the desired number of *Vol Decimal Digits* (digits to the right of the decimal point) in the volumetric flow display, and press [Enter].

### 2.4.1.2 Selecting Totalizer Units

4. Scroll to the desired *Totalizer Units* for the flow rate display and press [Enter]. Available units are listed in *Table 5* above.
5. Scroll to the desired number of *Tot Decimal Digits* (digits to the right of the decimal point in the totalized flow rate display) and press [Enter].
6. Do one of the following:
  - If MASS FLOW is ON, proceed to *Selecting Mass Flow Units* on page 26.
  - If MASS FLOW is OFF, the meter returns to the Global PROGRAM window. Press [Escape] twice and proceed to Chapter 3, *Operation*, or the *Programming Manual*.

**Note:** To activate mass flow, see *Activating Mass Flow in Chapter 1 of the Programming Manual*. The following prompts appear only if mass flow is activated for both channels.

### 2.4.1.3 Selecting Mass Flow Units

1. Scroll to the desired *Mass Flow* units for the flow rate display and press [Enter]. The available units for this prompt, which are determined by the selection made at the *System Units* screen, are shown in *Table 6* below.

**Table 6: Available Mass Flow Units**

English	Metric
LB = Pounds	Kilograms
KLB = Thousands of LB	Metric Tons (1000 KG)
MMLB = Millions of LB	
Tons (2000 LB)	

2. Scroll to the desired *Mass Flow Time* units for the mass flow rate display (from seconds to days) and press [Enter].
3. Scroll to the desired number of *Mdot Dec. Digits* (digits to the right of the decimal point in the mass flow rate display) and press [Enter].
4. Scroll to the desired *Mass (Totalizer)* units for the totalized mass flow rate display and press [Enter]. The available units for this prompt are determined by the selection made at the *System Units* prompt.
5. Scroll to the desired number of *Mass Dec. Digits* (digits to the right of the decimal point in the totalized mass flow rate display) and press [Enter].
6. Enter the *Molecular Weight (Mw)* and press [Enter].
7. After completing the above steps, the XGF868i returns to the Global PROGRAM window. Press [Escape] and scroll to CH1 or CH2 to continue setup programming.

## 2.5 Activating a Channel

The **Channelx-ACTIV** submenu permits selection of the desired measurement method. In addition, it is used to activate/deactivate one or both of the channels in a 2-Channel XGF868i.

To access the Channelx-ACTIV submenu:

1. From the *Keypad Program*, scroll to CH1 or CH2 and press [Enter].
2. In the Channel PROGRAM menu, scroll to ACTIV and press [Enter].
3. Scroll to *Burst* to activate the channel/path, and press [Enter].
4. Scroll to one of the measurement methods described below and press [Enter].
  - *Skon Only* is the preferred technique for locating the acoustic signal and for high velocity measurements. It is more robust in a noisy environment than the Measure technique.
  - *Skon/Measure* is the preferred technique to use for low velocity measurements.

If *Skon Only* is selected at the above prompt, the meter uses this technique exclusively. However, if *Skon/Measure* is selected, the meter uses *Skon Only* to find the acoustic signal and then tries to use the *Skon/Measure* technique for the actual measurement.

After completing the above step, the meter returns to the Channel PROGRAM window. Proceed to the next section to continue programming your meter.

## 2.6 Entering System Data for the Channel

The Channelx-System submenu is used to enter system parameters for the channel.

### 2.6.1 Accessing the Channelx-System Submenu

1. From the Channel PROGRAM menu, scroll to SYSTM and press [Enter].
2. The first prompt asks for the *Channel Label*. Use the four scrolling keys to enter the desired label (in any numeric or text combination up to five characters), and press [Enter].
3. The next prompt asks for the *Channel (Site) Message*. Enter the desired text in the same manner as the channel label with up to 15 characters, and press [Enter].

### 2.6.2 Selecting Volumetric Units

1. Scroll to the desired *Volumetric Units* for the flow rate display and press [Enter]. The available units are listed in *Table 7* below.
2. Scroll to the desired *Volumetric Time* units for the flow rate display (from seconds to days) and press [Enter].
3. Scroll to the desired number of *Vol Decimal Digits* (digits to the right of the decimal point in the volumetric flow rate display) and press [Enter].

**Table 7: Available Volumetric/Totalizer Units**

English	Metric
ACF = Actual Cubic Feet	ACM = Actual Cubic Meters
KACF = Thousands of ACF	KACM = Thousands of ACM
MMACF = Millions of ACF	MMACM = Millions of ACM
SCF = Standard Cubic Feet	SCM = Standard Cubic Meters
KSCF = Thousands of SCF	KSCM = Thousands of SCM
MMSCF = Millions of SCF	MMSCM = Millions of SCM

### 2.6.3 Selecting Totalizer Units

1. Scroll to the desired *Totalizer Units* for the totalized flow rate display and press [Enter]. Available units are listed in *Table 7* above.
2. Scroll to the desired number of *Tot Decimal Digits* (digits to the right of the decimal point in the totalized flow rate display) and press [Enter].

### 3. Do one of the following:

- If MASS FLOW is ON, proceed to *Selecting Mass Flow Units* on page 28.
- If MASS FLOW is OFF, the meter returns to the **Channel PROGRAM** window. Proceed to *Entering Transducer and Pipe Parameters* on page 28.

**Note:** To activate mass flow, see *Activating Mass Flow* in Chapter 1 of the Programming Manual.

## 2.6.4 Selecting Mass Flow Units

1. Scroll to the desired *Mass Flow* units for the flow rate display and press [Enter]. The available units for this prompt are determined by the selection made at the *System Units* prompt. See *Table 8* below.

**Table 8: Available Mass Flow Units**

English	Metric
LB = Pounds	Kilograms
KLB = Thousands of LB	Metric Tons (1000 KG)
MMLB = Millions of LB	
Tons (2000 LB)	

2. Scroll to the desired *Mass Flow Time* units for the mass flow rate display and press [Enter].
3. Scroll to the desired number of *Mdot Decimal Digits* (digits to the right of the decimal point in the mass flow rate display) and press [Enter].
4. Scroll to the desired *Mass (Totalizer)* units for the totalized mass flow rate display and press [Enter]. The available units for this prompt are determined by the selection made at the *System Units* prompt.
5. Scroll to the desired number of *Mass Dec. Digits* (digits to the right of the decimal point in the totalized mass flow rate display) and press [Enter].

After completing the above steps, the XGF868i returns to the Channel PROGRAM window. Proceed to the next section to program transducer and pipe parameters.

## 2.7 Entering Transducer and Pipe Parameters

Enter the transducer and pipe parameters via the **PIPE** submenu.

1. From the Channel PROGRAM menu, scroll to the PIPE option and press [Enter].
2. The first prompt asks for the *Transducer Number*.
  - For a standard transducer, use the arrow keys to enter the number engraved on the transducer head, and press [Enter].
  - If there is no number engraved on the transducer head, press the right arrow key to scroll to the *STD* option, and use the up and down arrow keys to change to *SPEC*. Then use the arrow keys to enter an assigned number (from 91 to 99), and press [Enter].

**IMPORTANT:** Special transducers, which have no engraved number on the head, are rarely used. Examine the transducer head carefully for a number.

- If you entered the number for a standard transducer, proceed to the *Pipe OD* prompt in step 5.
- If you entered the number for a special transducer, proceed to step 3 on the next page.

### 2.7.1 Special Transducers

3. Scroll to the transducer *Frequency* (supplied by the factory) and press [Enter].

**Note:** The frequency is required to transmit an excitation voltage at the transducer's natural frequency.

4. Enter the special transducer *Tw* (time delay) value (supplied by the factory) and press [Enter].

*Tw* is the time required for the transducer signal to travel through the transducer and its cable. This time delay must be subtracted from the transit times of the upstream and downstream transducers to ensure an accurate measurement.

## 2.7.2 Pipe Data

If either a standard or a special transducer is being used, the programming sequence should be rejoined at this point.

5. To select the appropriate *Pipe OD Unit* type from the list shown in *Table 9* below, scroll to the right side of the screen, and use the up and down arrow keys to step through the list. Press [Enter]. Then use the arrow keys to enter the known pipe outside diameter or circumference on the left side and press [Enter].

Obtain the required information by measuring either the pipe outside diameter (OD) or circumference at the transducer installation site. The data may also be obtained from standard pipe size tables found in *Sound Speeds and Pipe Size Data* (914-004).

**Table 9: Available Pipe OD Units**

English	Metric
inch	mm = millimeters
feet	m = meters
in/PI = pipe circumference in inches	mm/PI = pipe circumference in millimeters
ft/P I= pipe circumference in feet	m/PI = pipe circumference in meters

6. Use the arrow keys to enter the known *Pipe Wall Thickness* (in inches or mm) and press [Enter]. If the pipe wall thickness is not available, look up the value in a table of standard pipe size data which can be found in the *Sound Speeds and Pipe Size Data* manual (914-004).

## 2.7.3 Path and Axial Lengths

7. To enter the *Path Length*:
  - a. Use the [▷] arrow key to highlight the path length unit type at the right of the screen. Then use the [△] and [▽] arrow keys to scroll to the desired unit type.
  - b. Use the [◁] arrow key to return to the numeric entry on the left, and enter the path length of the ultrasonic signal. Press [Enter].

**Note:** *If a spoolpiece was ordered with the meter, the transducer signal path length (P) and the transducer signal axial length (L) are engraved on the flowcell and/or are included in the documentation supplied with the meter. For on-site transducer installations, refer to Appendix C, Measuring P and L Dimensions.*

8. In the same manner, enter the appropriate *Axial Length L* unit type and axial length of the ultrasonic signal, and press [Enter].
9. Scroll to the desired *Fluid Type* and press [Enter]. Then do one of the following:
  - If **OTHER** was selected - proceed to Step 10.
  - If **AIR** was selected - proceed to Step 11.
10. Use the arrow keys to enter the *Fluid Soundspeed* (in feet per second) in the gas to be measured and press [Enter].
11. Scroll to the appropriate choice to indicate whether you want *Reynolds Correction*, and press [Enter].
  - If *Off* is selected, go to Step 12.
  - If *On* is selected, the program asks for the *Kinematic Viscosity*. Use the arrow keys to enter the desired value, and press [Enter].
12. Use the arrow keys to enter a value for the flow *Calibration Factor* and press [Enter]. The default value is 1.00, but values between 0.50 and 2.0 may be entered.

### 2.7.3.1 Procedure Options

After completing the above steps, the XGF868i returns to the Channel PROGRAM window. Press [Escape] twice to return to the meter display. Then proceed to Chapter 3, *Operation*, for instructions on taking measurements, or refer to the *Programming Manual* for instructions on programming the XGF868i advanced features.

[no content intended for this page]

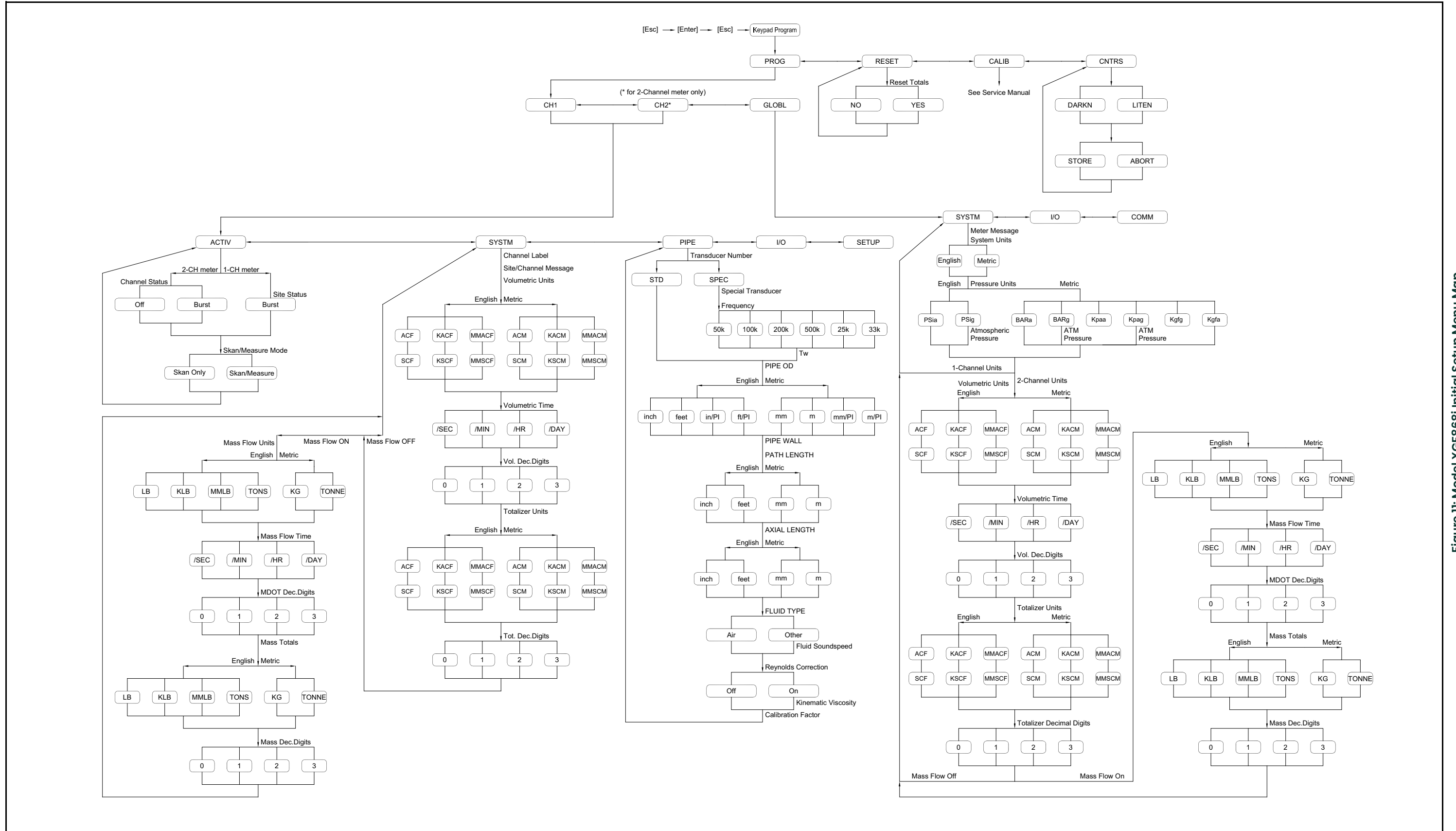

Figure 11: Model XGF868i Initial Setup Menu Map

[no content intended for this page]



## Chapter 3. Operation

### 3.1 Introduction

See Chapter 1, *Installation*, and Chapter 2, *Initial Setup*, to prepare the XGF868i system for operation. When the meter is ready to take measurements, proceed with this chapter. The following specific topics are discussed:

- Powering Up
- Using the Display
- Taking Measurements
- Recording Diagnostics

**Note:** *All inputs and outputs of the XGF868i are calibrated at the factory, prior to shipment. If it becomes necessary to recalibrate any of the inputs and/or outputs, see Chapter 1, Calibration, of the Service Manual for instructions.*



**WARNING!** To ensure the safe operation of the XGF868i, it must be installed and operated as described in this manual. In addition, be sure to follow all applicable local safety codes and regulations for the installation of electrical equipment.

### 3.2 Powering Up

Because the XGF868i does **not** have an ON/OFF switch, it will power up as soon as the connected power source is energized.

**IMPORTANT:** For compliance with the EU Low Voltage Directive (2006/95/EC), this unit requires an external power disconnect device such as a switch or circuit breaker. The disconnect device must be marked as such, clearly visible, directly accessible, and located within 1.8 m (6 ft) of the unit.

There are three methods for obtaining readings from the XGF868i:

- Built-in LCD display
- PanaView software on a computer
- Device to read the XGF868i analog output

At least one of the above display options must be installed in order to obtain flow rate readings from the meter.

Immediately upon power up the software version display appears. Then, the meter performs a series of internal checks, which take about 45 seconds, prior to displaying the flow rate data.

**Note:** *If the XGF868i fails any of the internal checks (see Chapter 2, Error Codes, in the Service Manual), try disconnecting the power and then repowering the unit. If the meter continues to fail any of the internal checks, contact Panametrics for assistance.*

After successfully performing the internal checks, the XGF868i begins taking measurements and the software version display is replaced by a measurement mode display. Proceed to the appropriate section for instructions on using the LCD display and the PanaView display option.

**Note:** *As a minimum, the system and pipe parameters (for each installed channel of a 2-channel meter) must be entered before the XGF868i can display valid data. Refer to Chapter 2, Initial Setup, for instructions.*

### 3.3 The LCD Display

The components of the LCD display are shown in *Figure 12* below, along with a typical mass flow rate readout.

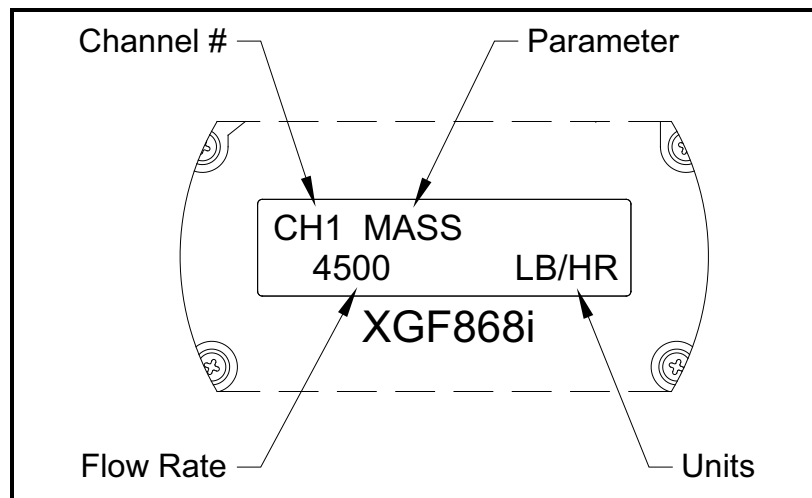

**Figure 12: A Typical LCD Flow Rate Display**

As shown in *Figure 12* above, the display screen includes the following information:

- Channel Number
- Flow Parameter
- Units of Measure
- Flow Rate Value

The example in *Figure 12* above uses the default display settings. However, the first three items in the list above may be reprogrammed to display a variety of alternative choices. See the *Programming Manual* for detailed instructions on programming these parameters.

**Note:** The LCD backlight flashes to signal errors. If the backlight is off when an error is detected, the display is illuminated briefly; if the backlight is already on, the light is interrupted briefly. Error code messages may appear in the upper right corner of the LCD display. For information about these error codes and how to respond to them, refer to Chapter 2, Error Codes, in the Service Manual.

Proceed to the *Taking Measurements* section to use the XGF868i.

### 3.4 The Optional PanaView Display

The components of the PanaView text display appear in *Figure 13* below, along with a typical flow rate readout.

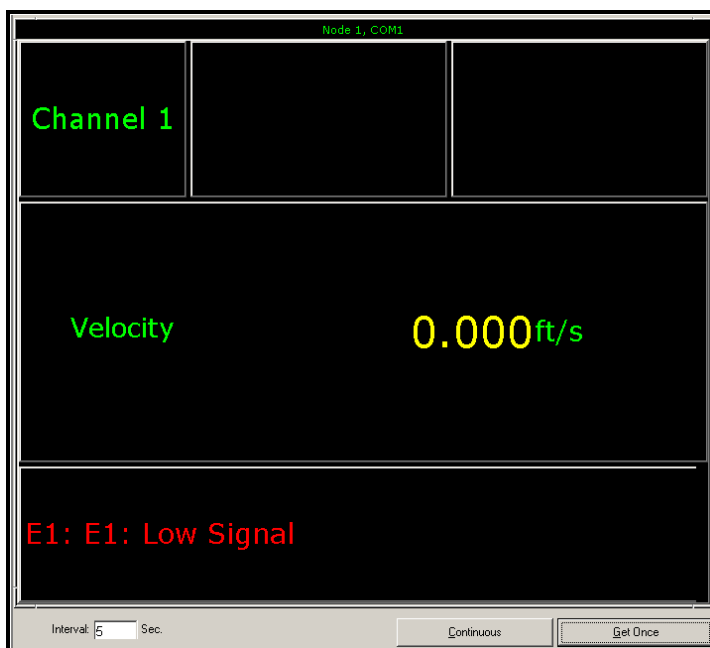

**Figure 13: A Typical PanaView Text Display Pane**

As shown in *Figure 13* above, the text pane includes the following information:

- Channel Number
- Flow Parameter
- Units of Measure
- Flow Rate Value

The example in *Figure 13* above is typical, but the first three items in the list above may be reprogrammed to display a variety of alternative choices. See the next section for detailed instructions on programming these parameters.

**Note:** Error code messages may appear in the lower left corner of the PanaView text display window. For information about these error codes and how to respond to them, refer to Chapter 2, Error Codes, in the Service Manual.

Proceed to the *Taking Measurements* section to use the XGF868i.

## 3.5 Taking Measurements

The XGF868i is capable of displaying several different variables in a variety of formats. However, this manual discusses only the basic measurement displays using the LCD display or the PanaView display. Refer to Chapter 2, *Displaying Data*, in the *Programming Manual* for instructions on setting up alternate choices. Also, refer to the *Programming Manual* and the *PanaView User's Manual* to use PanaView or the analog outputs to obtain the flow rate data.

### 3.5.1 Programming the LCD

**Note:** When you first initialize the XGF868i, the number of LCD parameters is set to OFF. You must program the LCD to display any measured parameters.

Through the *Keypad Program*, you can program the LCD display to display up to four variables in sequence. Complete the following steps to program the LCD display:

1. Power up the XGF868i and wait until it has initialized.
2. Press [Escape], [Enter], [Escape].
3. In the *Keypad Program* window, scroll to PROG and press [Enter].
4. In the PROG menu, scroll to GLOBL and press [Enter].
5. Scroll to I/O and press [Enter].
6. Scroll to LCD and press [Enter].
7. The window now asks for the # of LCD Parameters. Scroll to the desired number (from OFF through 1-4 and KEY) and press [Enter].

The OFF setting switches the measurement display off, while the KEY setting enables users to change the measurement display via the arrow keys, without accessing the *Keypad Program*. If you select KEY:

- To view a parameter other than the one currently displayed, press the [△] or [▽] keys to scroll through the various parameters.
  - To scroll through the channel options on a two-channel XGF868i, press the [◀] and [▶] keys until you have reached the desired option.
8. Scroll to the desired *Channel option*, as listed in *Table 10* below.

**Table 10: Channel Options**

Option	Description
CH1	Channel 1
CH2	Channel 2
SUM	CH1+CH2
DIF	CH1-CH2
AVE	$(CH1+CH2)/2$

9. For each channel, select the desired *Measurement Parameter*, as shown in *Table 11* below.

**Table 11: Available Measurement Parameters**

Option Bar	Description	Good	Bad
VEL	Displays the flow velocity.	N.A.	N.A.
VOLUM	Displays the volumetric flow.	N.A.	N.A.
+TOTL	Displays the forward totalized volume flow.	N.A.	N.A.
-TOTL	Displays the reverse totalized volume flow.	N.A.	N.A.
TIME	Displays the total flow measurement time.	N.A.	N.A.
MDOT	Displays the mass flow.	N.A.	N.A.
+MASS	Displays the forward totalized mass flow.	N.A.	N.A.

Table II: Available Measurement Parameters

Option Bar	Description	Good	Bad
-MASS	Displays the reverse totalized mass flow.	N.A.	N.A.
SS up	Displays the signal strength for the upstream transducer.	50-75	<50 or >75
SS do	Displays the signal strength for the downstream transducer.	50-75	<50 or >75
SNDSP	Displays the measured speed of sound in the gas.	N.A.	N.A.
Tup	Displays the upstream ultrasonic signal transit time.	N.A.	N.A.
Tdown	Displays the downstream ultrasonic signal transit time.	N.A.	N.A.
DELTA	Displays the transit time difference between the upstream and downstream signals.	N.A.	N.A.
Tot K	Displays the total K factor.	N.A.	N.A.
PEAK%	Displays the percentage of peak (set to +50 by default).	N.A.	N.A.
Qup	Displays the signal quality for the upstream transducer.	≥1200	-400 to +400
Qdown	Displays the signal quality for the downstream transducer.	≥1200	-400 to +400
AMPup	Displays the value for the signal amplitude of the upstream transducer.	24 ± 5	<19 or >29
AMPdn	Displays the value for the signal amplitude of the downstream transducer.	24 ± 5	<19 or >29
CNTup	Displays the AGC DAC count for the upstream gain setting.	N.A.	N.A.
CNTdn	Displays the AGC DAC count for downstream gain setting.	N.A.	N.A.
P#up	Displays signal peaks for the upstream transducer.	100-2300	<100 or >2300
P#dn	Displays signal peaks for the downstream transducer.	100-2300	<100 or >2300
TEMP	Displays the gas temperature (from 0/4-20 mA input).	N.A.	N.A.
PRESR	Displays the gas pressure (from 0/4-20 mA input).	N.A.	N.A.
Mw	Displays the molecular weight.	N.A.	N.A.
z	Displays the compressibility.	N.A.	N.A.
AcVOL	Displays actual volumetric flow.	N.A.	N.A.
StVOL	Displays standard volumetric flow.	N.A.	N.A.
Tu S <sup>1</sup>	Displays Skan transit time upstream.	N.A.	N.A.
Td S <sup>1</sup>	Displays Skan transit time downstream.	N.A.	N.A.
DT S <sup>1</sup>	Displays Skan Delta T.	N.A.	N.A.
Tu M <sup>1</sup>	Displays Measure transit time upstream.	N.A.	N.A.
Td M <sup>1</sup>	Displays Measure transit time downstream.	N.A.	N.A.
DT M <sup>1</sup>	Displays Measure Delta T.	N.A.	N.A.
Vinst	Displays the instantaneous velocity.	N.A.	N.A.

<sup>1</sup>available only if Burst Mode = S/M

**Note:** The measurement units that appear in these prompts are those selected in the **GLOBL-SYSTM** menu earlier in this section. Also, when differences in one channel's programming invalidate an output previously chosen for the other, the measurement defaults to the nearest selectable item in the parameter list.

The previous two prompts repeat until all of the specified **# of LCD Parameters** have been set up. When all of the display parameters have been set up, the meter returns to the **Global I/O** window. To leave the **Keypad Program**, press the **[Escape]** key three times.

After leaving the *Keypad Program*, the XGF868i will reset itself and will begin to display the parameters specified in this section. If more than one parameter was set up, each of the parameters will be displayed in sequence, with a pause of several seconds between display changes.

### 3.5.2 Using the LCD Display

To use the programmed LCD display for obtaining flow rate data, simply power on the XGF868i as described earlier in this chapter. Then, read the flow rate directly from the display, as shown in *Figure 12 on page 34*.

**Note:** See *Chapter 2, Displaying Data, in the Programming Manual to customize the contents of the LCD display*.

### 3.5.3 PanaView Display

Power up PanaView, establish communications with the XGF868i and enter the **required startup parameters**, as described in *Chapter 2, Initial Setup*. Then, proceed as follows:

**Note:** See *Chapter 2, Initial Setup, in this manual and/or Chapter 1, Programming Site Data, in the Programming Manual for complete instructions on entering startup data via PanaView*.

1. In PanaView, pull down the *Output* menu, as shown in *Figure 14 below*, and click on the *Text Display* option.

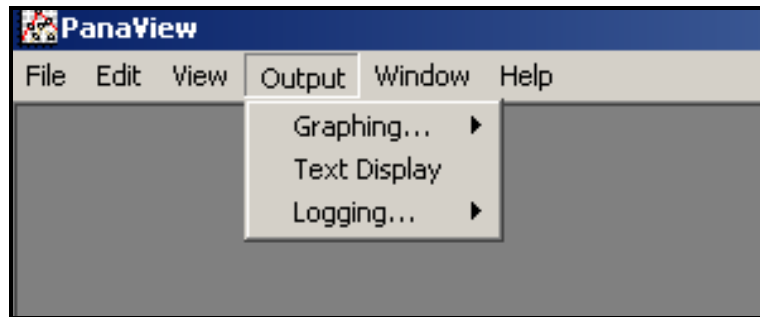

Figure 14: The Output Menu

**Note:** The *Text Display* window that appears after Step 1 is actually stacked on top of any previously opened windows (such as the *Meter Browser* window).

2. Using the *Window* menu, as described in the *PanaView User's Manual*, arrange the open windows in the desired format. For this discussion, *Figure 15 below* shows the *Text Display* window in its maximized (full-screen) size.

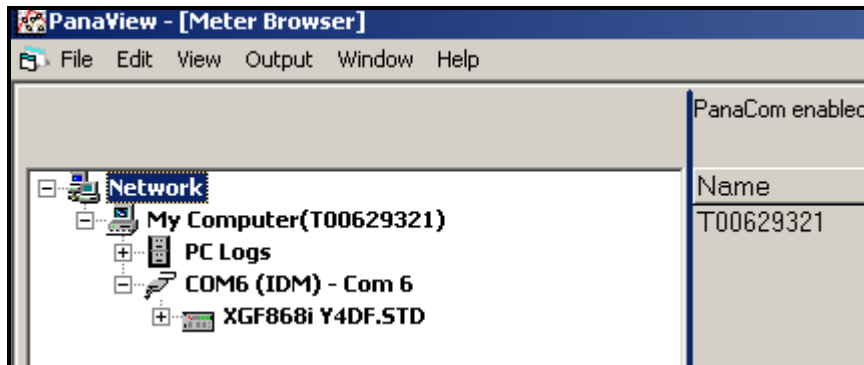

Figure 15: The Text Display Window

3. The left pane of the *Text Display* window contains the standard PanaView network tree. Expand the XGM branch, and double-click on the desired channel. (On 2-channel units, you can also display the SUM, DIFF or AVG parameters.)

4. From the expanded tree, double-click on the desired flow parameter to display it in the right pane of the window.
5. Before actual data values can be displayed in the text pane, activate one of the following data collection modes (see *Figure 15 on page 38*):
  - Click on the **[Get Once]** option button at the bottom of the right pane in the *Text Display* window. The current value of the selected process parameter, as specified in the PanaView network tree, is displayed in the right pane of the *Text Display* window.

or

- Enter an “interval” in the text box at the bottom of the right pane in the *Text Display* window, or check the “Max. Comm Rate” box to collect readings as fast as the system allows (1 sec). Then, click on the **[Continuous]** option button to begin collecting data for display in the right pane of the *Text Display* window.

**Note:** Any value entered in the “Interval” text box is overridden if the “Max. Comm Rate” box is checked.

The right pane now appears similar to *Figure 13 on page 35*.

6. If the **[Continuous]** option was selected in Step 5, click on the **[Stop]** option button, which has replaced the original **[Continuous]** option button, to terminate data collection.

The *Text Display* window may be left open while other tasks are performed, or it may be closed by clicking on the lower **[X]** control button at the far right of the menu bar.

**IMPORTANT:** If you click on the upper **[X]** control button at the far right of the PanaView title bar, you will exit PanaView completely.

### 3.5.3.1 Displaying Multiple Process Parameters

The procedure for displaying a single process parameter in a text screen may be repeated to simultaneously display multiple process parameters. To do so, proceed as follows:

1. Display the first process parameter in a text screen, as described in the previous section.
2. Repeat Step 1 for any desired additional process parameters, by double clicking on them in the PanaView network tree. PanaView automatically tiles the multiple text screens in the right pane of the *Text Display* window, as shown in *Figure 16* below.

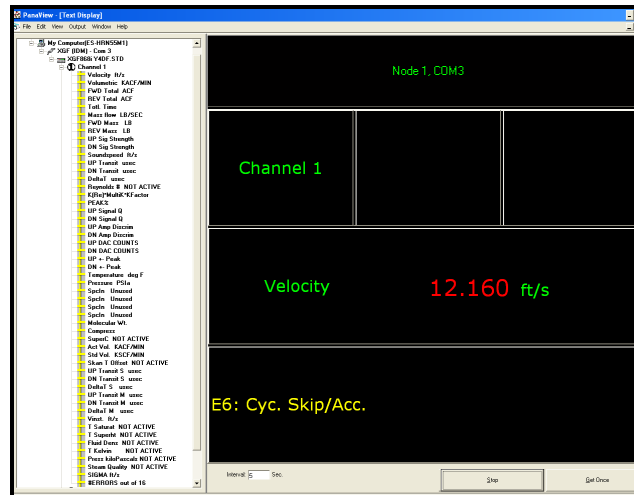

Figure 16: Multiple Text Screens in the *Text Display* Window

3. As in any standard Windows application, the multiple text screens may be resized by dragging their borders. Also, the individual panes within a parameter's text screen may be resized by dragging the borders within that text screen.
4. To close an open text screen, right click anywhere within that screen (except in the title bar or the error section) and click on the **[Remove]** option that pops up in the context menu.

**Note:** After resizing or removing any of the multiple text screens, the default tiled layout may be restored by opening the Window menu (see the PanaView User's Manual) and clicking on the *Tile Output Displays* option.

### 3.5.3.2 Displaying Multiple Text Windows

The procedures for displaying one or more process parameters in a single *Text Display* window may be repeated to open multiple *Text Display* windows. To do so, proceed as follows:

1. To open another *Text Display* window and display the desired process parameter(s) in the new window, repeat the steps in *PanaView Display*.
2. Arrange the multiple *Text Display* windows as desired via the *Window* menu (see the *PanaView User's Manual*).



### 3.5.4 Pausing Measurements

On occasion, it might become necessary for the XGF868i to stop taking measurements. Through PanaView, you can direct the XGF868i to pause measurements without cutting off the power from the meter.

1. From the meter tree in the *New Meter Browser*, click on the XGF868i entry.
2. Expand the *Edit Functions* option, and double-click on the *Pause Measurement* entry. A window opens similar to *Figure 17* below.

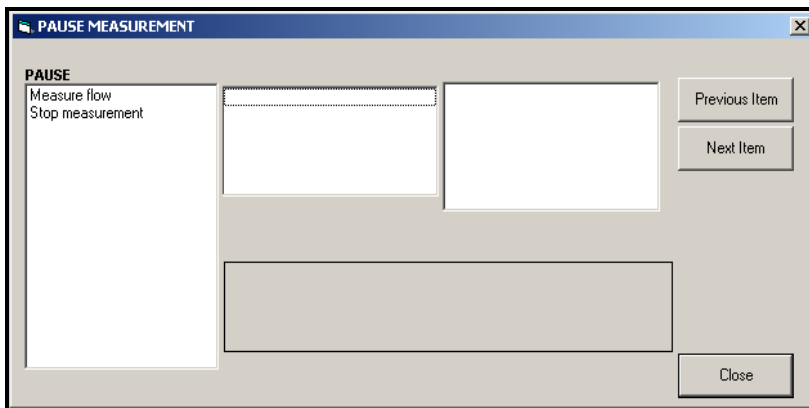

**Figure 17: The Pause Measurement Window**

3. To pause current measurements, double-click on the *Stop measurement* option. The window closes, and the XGF868i stops taking measurements.
4. To restart measurement, double-click on the *Pause Measurement* entry, and then on the *Measure flow* option. The XGF868i resumes flow measurement.

#### 3.5.4.1 Procedure Options

The *Startup Guide* is intended to provide only those instructions necessary to get the XGF868i installed and operating. By following the instructions in this chapter, the XGF868i can be set up to display the desired channel option and the desired measurement parameter, using either the LCD display or PanaView. To utilize the more advanced capabilities of the XGF868i, refer to the *Programming Manual* and/or the *Service Manual* for the instrument. Also, refer to the *PanaView User's Manual* for instructions on using the PanaView software with the XGF868i.

[no content intended for this page]

## Chapter 4. Specifications

### 4.1 Operation and Performance

#### 4.1.1 Fluid Types

Flare and vent gases

#### 4.1.2 Pipe Materials

All metals, fiberglass (Consult Panametrics for other materials)

#### 4.1.3 Pipe Sizes

14 to 120 in. NB ANSI (350 to 3000 mm)

#### 4.1.4 Flow Accuracy (Velocity)

##### 4.1.4.1 High Flow Range: $\pm 1.0$ ft/s to $\pm 394$ ft/s ( $\pm 0.3$ to $\pm 120$ m/s)

One-Path:  $\pm 2.0\%$

Two-Path:  $\pm 1.5\%$

**Note:** For 4 to 12 in. NB pipe sizes, accuracy ranges from 1.5 to 4% (consult Panametrics for details). Accuracy to  $\pm 0.5\%$  may be achieved with calibration.

##### 4.1.4.2 Low Flow Range: $\pm 0.1$ ft/s to $\pm 1.0$ ft/s ( $\pm 0.03$ to $\pm 0.3$ m/s)

One-Path:  $\pm 0.008$  f/s ( $\pm 0.002$  m/s)

Two-Path:  $\pm 0.0057$  f/s ( $\pm 0.0017$  m/s)

**Note:** Accuracies listed assume a fully developed flow profile. A minimum straight pipe run of 20 pipe diameters upstream and 10 pipe diameters downstream from the measurement point are recommended. Also, consult Panametrics for the accuracy of non-standard flow transducer types.

#### 4.1.5 Molecular Weight Accuracy

$\pm 1.8\%$  of reading for hydrocarbon mixtures with molecular weights of 2 to 120 gr/gr mole

#### 4.1.6 Mass Flow Accuracy

One-Path:  $\pm 2.7\%$

Two-Path:  $\pm 1.9\%$

**Note:** Dependent on the accuracy of the temperature and pressure inputs.

#### 4.1.7 Repeatability

##### 4.1.7.1 High Flow Range: $\pm 1.0$ ft/s to $\pm 394$ ft/s ( $\pm 0.3$ to $\pm 120$ m/s)

One-Path:  $\pm 0.5$  to  $1.0\%$

Two-Path:  $\pm 0.35$  to  $0.75\%$

##### 4.1.7.2 Low Flow Range: $\pm 0.1$ ft/s to $\pm 1.0$ ft/s ( $\pm 0.03$ to $\pm 0.3$ m/s)

One-Path:  $\pm 5$  to  $6\%$

Two-Path:  $\pm 3.5$  to  $4.0$

#### 4.1.8 Rangeability (Overall)

4000:1

## 4.2 Electronics

### 4.2.1 Flow Measurement

Patented *Correlation Transit-Time* mode

## 4.2.2 Enclosures

*Standard:* Epoxy-coated aluminum, Hazardous area ratings:

**Explosion-proof:** Class I, Division 1, Groups B, C, D

**Flameproof:** ISSeP 07ATEX015

II 2 G Ex d IIC T5 IP66

**IECEx:** FM G 0011x

II 2 G Ex IIC T6 Gb IP66

*Optional:* Stainless steel

## 4.2.3 Dimensions (l x d)

8.2 in. x 6.6 in. (208 mm x 168 mm)

## 4.2.4 Weight

*Aluminum:* 10 lb (4.5 kg)

*Stainless steel:* 30 lb (13.6 kg)

## 4.2.5 Channels

*Standard:* Two channels (for two-path averaging)

## 4.2.6 Display

2 line x 12 character backlit LCD display,  
configurable to display up to four measurement parameters in sequence

## 4.2.7 Keypad

Built-in magnetic six-button keypad for full functionality operation

## 4.2.8 Power Supplies

*Standard:* 100 to 240 VAC, 50/60 Hz,  $\pm 10\%$ .

*Optional:* 12 to 28 VDC,  $\pm 5\%$ .

## 4.2.9 Power Consumption

20 W maximum

## 4.2.10 Operating Temperature

-40°F to 140°F (-40°C to 60°C)

## 4.2.11 Storage Temperature

-67°F to 167°F (-55°C to 75°C)

## 4.2.12 Standard Inputs and Outputs

Two 0/4 to 20 mA isolated analog outputs, 600  $\Omega$  maximum load, and

Two 4 to 20 mA isolated analog inputs, 24 VDC loop power

or

One 4 to 20 mA isolated analog inputs, 24 VDC loop power, and

One direct three-wire RTD (temperature) input, -148°F to 662°F (-100°C to 350°C), 100  $\Omega$  platinum

## 4.2.13 Optional Inputs and Outputs

Two optically isolated frequency outputs, 3 A maximum, 100 VDC maximum,

1 W maximum, from DC to 10 kHz maximum

#### 4.2.14 Digital Interfaces

*Standard:* RS232 (PanaView (PC software))

HART<sup>®</sup> protocol on 4–20 mA output

*Optional:* Modbus<sup>®</sup> TCP/IP

Ethernet

OPC Server

Foundation Fieldbus<sup>®</sup>

#### 4.2.15 European Compliance

*System:* Directives EMC 2004/108/EC, LVD 2006/95/EC (Installation Category II, Pollution Degree 2)

*Transducers:* PED Directive 97/23/EC for DN<25

[See the *CE Declaration of Conformity* at the back of this manual.]

### 4.3 Wetted Ultrasonic Flow Transducers

#### 4.3.1 Temperature Range

*Overall:* -364°F to 536°F (-220°C to 280°C)

**Note:** Transducer type selection is based on specific application review.

#### 4.3.2 Pressure Range

*Standard:* 2 psig to 1500 psig (87.6 kPa to 10300 kPa)

#### 4.3.3 Materials

*Standard:* Titanium

*Optional:* Monel<sup>®</sup> or Hastelloy<sup>®</sup> alloys

#### 4.3.4 Process Connections

Flanged and compression fittings

#### 4.3.5 Area Classifications

*Standard:* Epoxy-coated aluminum, Hazardous area ratings:

**Explosion-proof:** Class I, Division 1, Groups C, D

**Flameproof:** II 2 G Ex d IIC T4, T3 or T2 Gb

**IECEx:** Ex d IIC T4, T3 or T2 Gb

*Optional:* Class I, Division 1, Group B

### 4.4 Insertion Mechanism

#### 4.4.1 Standard Range

3 in. (76 mm) flange-mounted packing gland and valve with equal mounting angles upstream and downstream

#### 4.4.2 Extended Velocity Range

3 in. (76 mm) flange-mounted packing gland and valve with *Recovery Angle* in downstream assembly

### 4.5 Preamplifier

#### 4.5.1 Physical

In-line, powered preamplifier with transformer and BNC connections. One preamplifier with transformer is required per transducer per channel.

## 4.5.2 Gain

Standard: 20

Optional: 2, 10, 40 (factory selected)

## 4.5.3 Temperature Range

-40°F to 60°F (-40°C to 140°C)

## 4.5.4 Enclosure

Explosion-proof: Class I, Division 1, Groups C, D (Optional: Group B upon request)

ATEX Flameproof: II 2 G Ex d IIC T4, T3 or T2 Gb

IECEx Flameproof: Ex d IIC T4, T3 or T2 Gb

## 4.6 Transducer Cables

### 4.6.1 Standard (per Transducer pair)

- One pair of coaxial cables for transducer to preamplifier connections (if required), type RG62A/U, length 3m (10 ft)
- One pair of coaxial cables for preamplifier to XGF868i electronics, type RG62A/U, length 10 ft (3 m) to 1000 ft (330 m) maximum

### 4.6.2 Optional

flame retardant, armored cable; cable glands

## 4.7 Options

### 4.7.1 PanaView™ PC-Resident Interface Software

Using the *PanaView* software, the *DigitalFlow™ XGF868i* flow transmitter communicates with a PC running a *Windows®* operating system through a serial interface. Features include *site files*, *logs* and other operations.

### 4.7.2 Installation Flowcells

Flanged or plain-end spoolpiece, with hot tap or cold tap transducer connections

**Note:** Consult with Panametrics for the availability of transducers and flowcells for specific applications.

### 4.7.3 Pressure and Temperature Transducers

Available upon request.

## Appendix A. CE Mark Compliance

### A.1 Introduction

For CE Mark compliance, the XGF868i flow transmitter must be wired in accordance with the instructions in this appendix.

**IMPORTANT:** CE Mark compliance is required for all units intended for use in EU countries.

### A.2 Wiring

The XGF868i must be wired with the recommended cable, and all connections must be properly shielded and grounded. Refer to *Table 12* below for the specific requirements. All interconnecting cables shall comply with IEC/EN 60079-14.

**Table 12: Wiring Requirements**

Connection	Cable Type	Ground Termination
Transducer	Armored RG62 a/U	Grounded via cable gland.
Input/Output	Armored 22 AWG shielded (e.g. Baystate #78-1197) with armored material added to outside of jacket	Grounded via cable gland.
Power	Armored 14 AWG 3 conductor	Grounded via cable gland.



**WARNING!** To ensure safe and reliable operation of the XGF868i, be sure to install and tighten all cable glands in accordance with the gland manufacturer's instructions.

**Note:** If the XGF868i is wired as described in this appendix, the unit will comply with the EMC Directive 2004/108/EC.

[no content intended for this page]



## Appendix B. Data Records

### B.1 Available Option Cards

The XGF868i can hold one option card in Slot 1 and one in Slot 2. The available configurations are listed in *Table 13* below.

**Table 13: Option Card Configurations**

Card #	Slot #	Configuration
1473-02	1	OI - 2 Current Inputs
1473-14		OR - 1 RTD Input/1 Current Input
1473-06		FI - 2 Current Inputs/2 Frequency Outputs
1473-15		FR - FRI- 2 Frequency Outputs/1 RTD Input/1 Current Input
1345-04	2	Modbus Communications Protocol
1658		HART Communication
1477-03		MODBUS/TCP/IP
1477-01		Ethernet
1475-01		Foundation Fieldbus

## B.2 Option Cards Installed

Whenever an option card is installed or changed in the XGF868i flow transmitter, record the type of card and any additional setup information in the appropriate row of *Table 14* below.

**Table 14: Option Cards Installed**

Slot #	Type of Option Card	Additional Setup Information
0	Analog Outputs (A, B)	
1		
2		

### B.3 Setup Data

After the XGF868i flow transmitter has been installed, setup data must be entered via the *User Program* prior to operation. Record that information in *Table 15* below.

**Table 15: Setup Data**

General Information						
Model #				Serial #		
Software Version				Setup Date		
Channel - Status						
Channel 1				Channel 2		
Channel Status	Off	Burst		Channel Status	Off	Burst
Measure Mode	Skon	S/M		Measure Mode	Skon	S/M
Channel - System						
Channel Label				Channel Label		
Site/Channel Msg.				Channel Message		
Vol. Units				Vol. Units		
Vol. Time Units				Vol. Time Units		
Vol. Dec. Digits				Vol. Dec. Digits		
Totalizer Units				Totalizer Units		
Tot. Dec. Digits				Tot. Dec. Digits		
Mass Flow				Mass Flow		
Mass Flow Time				Mass Flow Time		
MDOT Dec. Digits				MDOT Dec. Digits		
Mass Totalizer				Mass Totalizer		
Mass Dec. Digits				Mass Dec. Digits		
Mol. Weight				Mol. Weight		

Table 15: Setup Data

Channel - Pipe Parameters						
Channel 1			Channel 2			
Trans. Type	STD	SPEC	Trans. Type	STD	SPEC	
Transducer #			Transducer #			
Spec. Trans. Freq.			Spec. Trans. Hz			
Spec. Trans. Tw			Spec. Trans. Tw			
Pipe O.D.			Pipe O.D.			
Pipe Wall			Pipe Wall			
Path Length (P)			Path Length (P)			
Axial Length (L)			Axial Length (L)			
Fluid Type	Air	Other	Fluid Type	Air	Other	
Other/Sndspd			Other/Sndspd			
Calibration Factor			Calibration Factor			
Channel - Input/Output						
Zero Cutoff			Zero Cutoff			
Temp. Input			Temp. Input			
Base Temp.			Base Temp.			
Pressure Input			Pressure Input			
Base Pressure			Base Pressure			
Low Press. Switch	No	Yes	Low Press. Switch	No	Yes	
Pressure Limit			Pressure Limit			
Channel - SETUP - V Averaging						
Response Time			Response Time			
Channel - SETUP - Advanced Features - Multi K Factors						
K-Factor #	Velocity	K-Factor	K Factor #	Velocity	K-Factor	
1			1			
2			2			
3			3			
4			4			
5			5			
6			6			
7			7			
8			8			
9			9			
10			10			

Table 15: Setup Data

<b>Channel - SETUP - Advanced Features - Multi K Factors (cont.)</b>						
K-Factor #	Velocity	K-Factor		K Factor #	Velocity	K-Factor
11				11		
12				12		
13				13		
14				14		
15				15		
16				16		
17				17		
18				18		
19				19		
20				20		
<b>Channel - SETUP - Advanced Features - Mass Flow Calculation</b>						
Mass Flow	Yes	No		Mass Flow	Yes	No
Density Type	Fluid Dens.	Mol. Wt.		Density Type	Fluid Dens.	Mol. Wt.
Q <sub>act</sub> or Q <sub>std</sub> ?	Actual	Standard		Q <sub>act</sub> or Q <sub>std</sub> ?	Actual	Standard
Fluid Density				Fluid Density		
Mol. Weight				Mol. Weight		
<b>Global - System</b>						
Meter Message				Totalizer Units		
System Units	English	Metric		Tot. Dec. Digits		
Pressure Units				Mass Flow		
Atmos. Pressure				Mass Flow Time		
Vol. Units				MDOT Dec. Digit		
Vol. Time Units				Mass Totals		
Vol. Dec. Digits				Mass Dec. Digits		
<b>Global - Input/Output - Error Handling</b>						
Error Handling				2-Path Error	No	Yes
<b>Global - Communications Port</b>						
Meter Address				MOD. Parity		
Baud Rate				MOD. Stop Bits		
MOD. Baud Rate				MOD. Address		

[no content intended for this page]

## Appendix C. Measuring P and L Dimensions

### C.1 Introduction

When programming the PIPE menu in the XGF868i *User Program*, the *path length* (P) and the *axial dimension* (L) must be entered. These parameters are determined by measurements on the actual transducer installation, with P equal to the face-to-face distance between the transducers and L equal to the axial distance between the centers of the transducer faces.

The accuracy of the programmed P and L values is critical to precise flow rate measurements. If Panametrics supplies the flowcell for the system, the correct values will be included in the documentation supplied with the system. For transducers installed on an existing pipe (see Figure 18 on page 56), P and L must be measured at the site. This appendix provides instructions for properly determining these dimensions.

### C.2 Measuring P and L

Whenever possible, physically measure the face-to-face distance (P) and the axial distance (L) between the centers of the flat faces of the transducers. Refer to *Figure 18 on page 56* for an illustration of the proper distances to measure, in a typical installation.

In some situations only one of the required distances can be directly measured. When this happens, a knowledge of the installation angle ( $\theta$ ) of the transducers, permits the second distance to be calculated from *Equation C-1* below.

$$\cos\theta = \frac{L}{P}$$

As an example, assume that the transducer installation angle is known to be 45° and the L distance is measured to be 10.00 inches. Then, the P distance is calculated to be  $P = 10.00/0.707 = 14.14$  inches.

With a Bias 90° transducer installation, it sometimes happens that the only known parameters are the transducer angle ( $\theta$ ) and the centerline distance between the transducer bodies (CL). In these cases, it is still possible to calculate P and L by combining *Equation C-1* above with the additional *Equation C-2* below (see *Figure 18 on page 56*):

$$P = CL - 1.2$$

Standard Panametrics 90° transducers have the face offset from the centerline of the body by 0.6 inches. Thus, a pair of transducers has a total offset of 1.2 inches, as indicated in *Equation C-2*. For example, suppose that the transducer installation angle is 30° and CL is measured to be 12.00 inches. Then,  $P = 12.00 - 1.2 = 10.80$  inches and  $L = 10.80 \times 0.866 = 9.35$  inches.

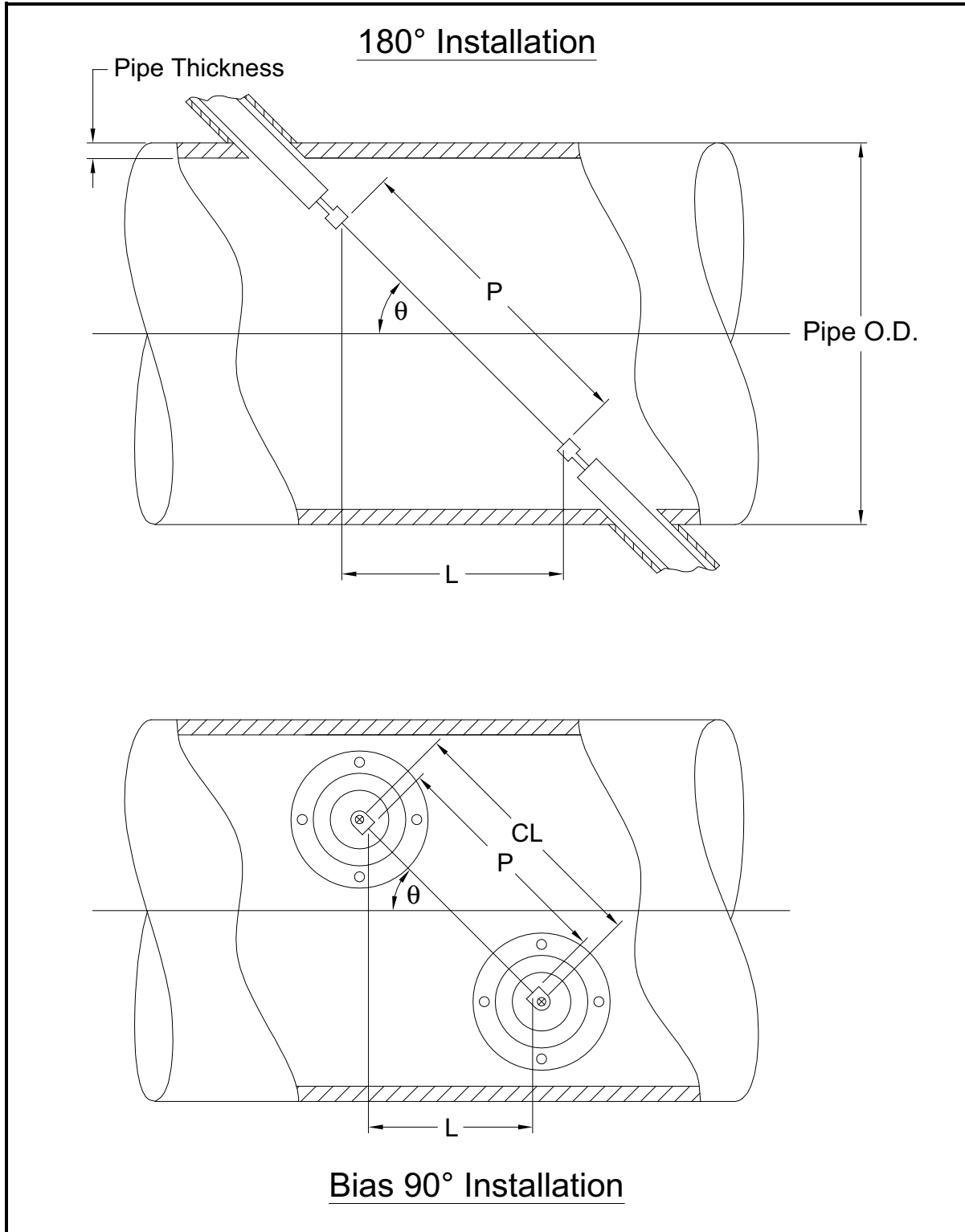

Figure 18: Top View of Typical Transducer Installations



# Index

	<b>Symbols</b>			
+MASS .....		36		
+TOTL .....		36		
	<b>A</b>			
Activating a Channel .....		27		
AcVOL .....		37		
AMPdn .....		37		
AMPup .....		37		
Analog Inputs Option Card				
Connecting .....		13		
Pin Assignments .....		13		
Rating .....		13		
Analog Outputs (Slot 0), Connecting .....		10		
Analog Outputs Option Card, Connecting .....		14		
Arrow Keys .....		24		
Axial Dimension, Measuring .....		55		
Axial Length .....		29		
	<b>C</b>			
Cable				
Serial Port .....		11		
Transducers .....		3, 8, 9, 46		
CE Mark Compliance .....		47		
Channel Label .....		27		
Channel Message .....		27		
Channel System Data				
Accessing the Submenu .....		27		
Entering .....		27		
Mass Flow Units, Selecting .....		28		
Totalizer Units .....		27		
Volumetric Units .....		27		
Channel, Activating .....		27		
CNTdn .....		37		
CNTup .....		37		
Connectors, Electrical .....		5		
	<b>D</b>			
DELTA .....		37		
Display Data .....		33		
Down Arrow Key .....		24		
DT M .....		37		
DT S .....		37		
	<b>E</b>			
Electrical Connectors .....		5		
Electronics Enclosure				
Description .....		2		
Mounting .....		5		
Enter Key .....		24		
Error Codes .....		34, 35		
Escape Key .....		24		
Ethernet, Wiring .....		15		
	<b>F</b>			
Flowcell				
Description .....		2		
Installing .....		3		
Fluid				
Soundspeed, Entering .....		29		
Type, Entering .....		29		
	<b>G</b>			
GLOBL Menu				
LCD Option .....		36		
Mass Flow Units, Selecting .....		26		
Programming .....		25		
System Data, Entering .....		25		
System Units, Selecting .....		25		
SYSTEM Submenu .....		25		
Totalizer Units, Selecting .....		26		
	<b>I</b>			
I/O (Global) Submenu, LCD Option .....		36		
Initial Setup				
Data Table .....		51		
Minimum Required .....		23		
Input Voltage .....		7		
Insertion Mechanism, Transducers .....		45		
Installation				
Site Considerations .....		2		
Unpacking .....		1		
Internal Tests .....		33		
	<b>K</b>			
Keypad Program				
Entering .....		25		
Exiting, Automatic .....		25		
LCD Option .....		36		
KV Input Selection .....		29		
	<b>L</b>			
LCD				
Option .....		36		
Setting Up .....		36		
Left Arrow Key .....		24		
Lightning Protector, Connecting .....		9		
Liquid Crystal Display				
see LCD				
LVD Statement .....		2		
	<b>M</b>			
Magnetic Keypad, Using .....		24		
-MASS .....		37		
Mass Flow Units				
Channel, Selecting .....		28		
Global, Selecting .....		26		
MDOT .....		36		
Measurements				
Displaying .....		33		
Parameters, Available .....		36		
Taking .....		33, 36		
Menus, Output .....		38		

MODBUS/TCP, Wiring .....	15	Soundspeed (SNDSP) Parameter .....	37
<b>O</b>		Special Transducers, Entering Number .....	28
Option Cards		Specifications	
Analog Inputs .....	13	Electronics .....	43
Analog Outputs .....	14	Insertion Mechanism .....	45
RTD Inputs .....	14	Operation and Performance .....	43
Setup Information Table .....	50	Options .....	46
Totalizer/Frequency Outputs .....	14	Preamplifier .....	45
Types Available .....	49	Transducer Cables .....	46
Wiring .....	12	Transducers .....	45
Options .....	46	XGF868i .....	43
Output Menu .....	38	SS do .....	37
<b>P</b>		SS up .....	37
P#dn .....	37	StVOL .....	37
P#up .....	37	System Data (Channel), Entering .....	27
PanaView, Displaying Data in .....	35	System Units, Selecting .....	25
Path Length, Measuring .....	55	SYSTEM Submenu .....	25
Pausing Measurement .....	41	<b>T</b>	
PEAK% .....	37	Td M .....	37
Pipe OD, Programming .....	29	Td S .....	37
Pipe Parameters		Tdown .....	37
Axial Length .....	29	TEMP .....	37
Entering .....	28	Temperature Transmitter	
OD/Circumference .....	29	Installing .....	4
Path Length .....	29	Location .....	3
Special Transducer Number .....	28	RTD .....	4
Wall Thickness .....	29	Terminal Block	
Powering Up		Analog Outputs - I/O .....	10
Display .....	33	Power - TBI .....	7
Internal Checks .....	33	Serial Port - RS232 .....	11
Preamplifier		Transducers - CH1/CH2 .....	9
Local (XAMP), Connecting .....	8	Text Displays, Multiple Parameter .....	40
Remote (PRE868), Connecting .....	9	Text Windows, Multiple .....	40
Specifications .....	45	TIMER .....	36
PRESR .....	37	Tot K .....	37
Pressure Transmitter		Totalizer Units	
Installing .....	4	Channel, Selecting .....	27
Location .....	3	Global, Selecting .....	26
<b>Q</b>		Totalizer/Frequency Option Card, Connecting .....	14
Qdown .....	37	-TOTL .....	36
Qup .....	37	Tracking Windows, Activating .....	29
<b>R</b>		Transducer and Pipe Parameters, Entering .....	28
Return Policy .....	61	Transducer Cables, Specifications .....	46
Right Arrow Key .....	24	Transducer Number .....	28
RS232 Port		Transducer Parameters, Programming .....	28
See Serial Port		Transducers	
RTD Inputs Option Card, Connecting .....	14	180° Installation .....	55
RTD Temperature Transmitter .....	4	Axial Dimension .....	55
<b>S</b>		Bias 90° Installation .....	55
Serial Port		Cables .....	3, 8, 9, 46
Cable .....	11	Connecting .....	8, 9
Connecting .....	11	Installation Angle .....	55
Pin Assignments .....	11	Location .....	2
Site Considerations .....	2	Path Length .....	55
Slot 0		Special, Entering Number .....	28
See Analog Outputs (Slot 0)		Transmitter	
		See Temperature or Pressure Transmitter	
		Tu M .....	37

---

Tu S .....	37
Tup .....	37
<b>U</b>	
Unpacking .....	1
Up Arrow Key .....	24
<b>V</b>	
VEL .....	36
Vinst .....	37
Voltage, Input .....	7
VOLUM .....	36
<b>W</b>	
Warranty .....	61
Windows	
Resizing .....	40
Tiling .....	40
Wiring	
CE Mark Compliance .....	47
Option Card .....	See Card Name
Terminal Block .....	See Block Name

[no content intended for this page]

---

## Warranty

Each instrument manufactured by Panametrics is warranted to be free from defects in material and workmanship. Liability under this warranty is limited to restoring the instrument to normal operation or replacing the instrument, at the sole discretion of Panametrics. Fuses and batteries are specifically excluded from any liability. This warranty is effective from the date of delivery to the original purchaser. If Panametrics determines that the equipment was defective, the warranty period is:

- one year from delivery for electronic or mechanical failures
- one year from delivery for sensor shelf life

If Panametrics determines that the equipment was damaged by misuse, improper installation, the use of unauthorized replacement parts, or operating conditions outside the guidelines specified by Panametrics, the repairs are not covered under this warranty.

---

**The warranties set forth herein are exclusive and are in lieu of all other warranties whether statutory, express or implied (including warranties or merchantability and fitness for a particular purpose, and warranties arising from course of dealing or usage or trade).**

---

## Return Policy

If a Panametrics instrument malfunctions within the warranty period, the following procedure must be completed:

1. Notify Panametrics, giving full details of the problem, and provide the model number and serial number of the instrument. If the nature of the problem indicates the need for factory service, Panametrics will issue a RETURN AUTHORIZATION NUMBER (RAN), and shipping instructions for the return of the instrument to a service center will be provided.
2. If Panametrics instructs you to send your instrument to a service center, it must be shipped prepaid to the authorized repair station indicated in the shipping instructions.
3. Upon receipt, Panametrics will evaluate the instrument to determine the cause of the malfunction.

Then, one of the following courses of action will then be taken:

- If the damage is covered under the terms of the warranty, the instrument will be repaired at no cost to the owner and returned.
- If Panametrics determines that the damage is not covered under the terms of the warranty, or if the warranty has expired, an estimate for the cost of the repairs at standard rates will be provided. Upon receipt of the owner's approval to proceed, the instrument will be repaired and returned.

[no content intended for this page]



## Customer Support Centers

### U.S.A.

The Boston Center  
1100 Technology Park Drive  
Billerica, MA 01821

U.S.A.

Tel: 800 833 9438 (toll-free)  
978 437 1000

E-mail: [panametricstechsupport@bakerhughes.com](mailto:panametricstechsupport@bakerhughes.com)

### Ireland

Sensing House  
Shannon Free Zone East  
Shannon, County Clare  
Ireland

Tel: +353 (0)61 470200

E-mail: [panametricstechsupport@bakerhughes.com](mailto:panametricstechsupport@bakerhughes.com)

Copyright 2023 Baker Hughes company.

This material contains one or more registered trademarks of Baker Hughes Company and its subsidiaries in one or more countries. All third-party product and company names are trademarks of their respective holders.

BH060C41 EN D (04/2023)

**Baker Hughes** 